

ARMSTRONG



Circulator Parts Catalog

FILE NO:	6010.201
DATE:	Apr. 16, 2008
SUPERSEDES:	6010.201
DATE:	Sept. 14, 2005

ARMSTRONG

CIRCULATOR

SERVICE PARTS

ORDERING INSTRUCTIONS

Part Number identification for ordering purposes may be determined by obtaining the item number of the required part from the Assembly Drawing on page 1, then referring to the Service Parts Tables on pages 3 to 25 under the Model Number of the Circulator and class of construction as provided on the pump nameplate. Always specify the Circulator Model Number and Serial Number with your order. For service kits see page 26

CONSTRUCTION CODE

STD. - Denotes "Universal" or "Standard" construction.

IBBF or BF - denotes "Bronze"-Fitted" construction.

AB - denotes "All Bronze" construction.

AI - denotes "All Iron" construction.

When no construction code is provided on pump nameplate, the Circulator is classed as "Standard Construction". Choose service parts from the lists with this heading.

SERIAL NUMBER CODE

All Armstrong Standard and High Duty Circulators bear a four-digit combination serial and date code denoting year and month of manufacture. For example, a Circulator manufactured in June of 2001 would bear the serial date code of 0106 on the nameplate. Series 1050 Circulators bear the four digit serial date code if their custom feature is impeller diameter and/or special motor. However, if special materials of construction, special seals, etc. are used, a straight numerical serial number appears on the pump nameplate and must be specified when ordering. Such parts must be ordered from factory unless actual part number has been established and carried in a service dealer's stock.

TREATED SYSTEM WATER

Additives for sealing system leaks, and some water treatments, improperly applied, are injurious to pump seals. New hydronic systems should thoroughly washed, fully drained and refilled with clean water before running pump. System must be kept clean of foreign materials such as welding slag, etc.

Stop-leak compounds or cleaning chemicals must be thoroughly flushed out after using.

Circulator and/or Service Parts Warranty will be void if chemicals are improperly used or if stop-leak compound is left in system.

Service Parts For Armstrong Circulators

TYPICAL ASSEMBLY DETAILS

MODEL	H.P.	SIZE	MODEL	H.P.	SIZE
S25	1/12	2	S34	1/6	3
S35	1/6	3	S45	1/4	4
S46	1/4	4	S55	1/2	5
S57	3/4	5	H32	1/6	3
H41	1/6	4	H51	1/4	5
H52	1/3	5	H53	1/2	5
H54	3/4	5	1050	1/4 TO 3/4	5

EXPLODED VIEW APPLIES TO CIRCULATORS LISTED ABOVE

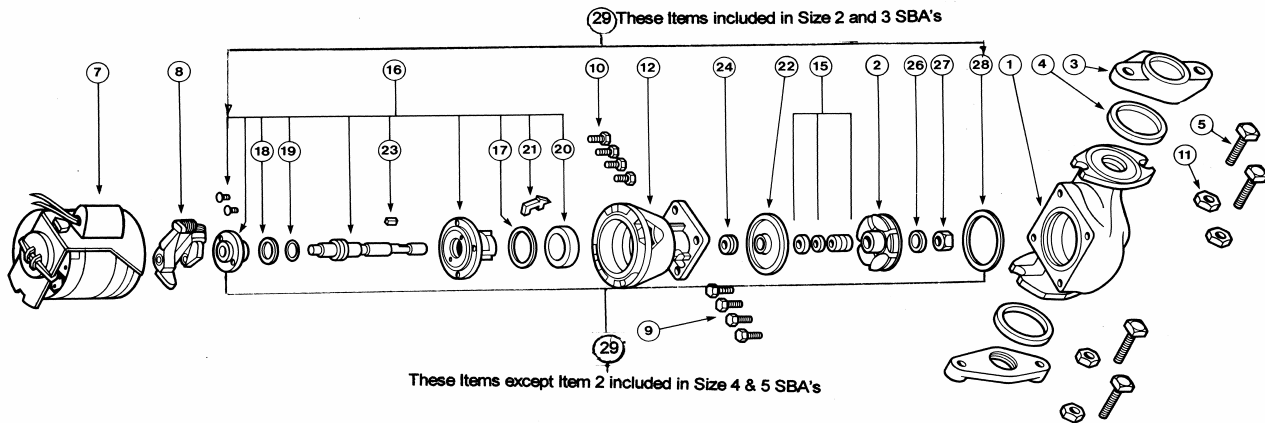

MODEL	H.P.	SIZE	MODEL	H.P.	SIZE
S69	1	6	H63	1/2	6
H64	3/4	6	H65	3/4	6
H65	1	6	H66	3/4	6
H67	1	6	H68	1 1/2	6
1060	1/2 TO 1 1/2	6	1060 3D	1 TO 3	6

EXPLODED VIEW APPLIES TO CIRCULATORS LISTED ABOVE

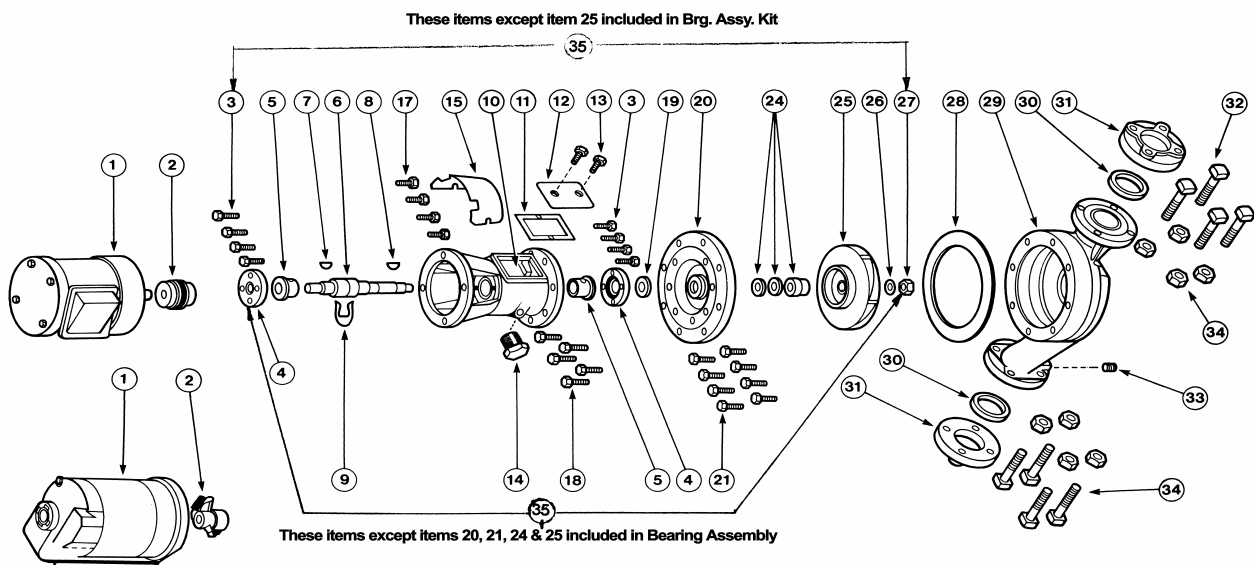

*C: FLANGE MOUNTED MOTOR FOR MODEL H68 AND SERIES 1060 OVER 1 HP.

Service Parts For Armstrong Circulators

MODEL DESIGNATIONS AND PARTS PAGE INDEX

STANDARD CIRCULATORS

SIZE	2			3				5		
CATALOG MODEL NO.	S25	S25	S25	S25	S34	S35	S45	S46	S55	S57
FLANGE SIZE NPT (INCHES)	3/4	1	1 1/4	1 1/2	OBSOLETE USE H32 1 1/2" PARTS LIST	2	3	3	3	3
PARTS LIST PAGE NUMBER	4-8			14-18		24-28	29-33	34-38	39-43	
FORMER MODEL NUMBER	#75	#100	#125	#150		2	3LD	3HD	PD35	PD37

HIGH DUTY CIRCULATORS

SIZE	3			4	5			
CATALOG MODEL NO.	H32	H32	H32	H41	H51	H52	H53	H54
FLANGE SIZE NPT (INCHES)	1	1 1/4	1 1/2	1	1	1 1/4	1 1/2	2
PARTS LIST PAGE NUMBER	9-13			19-23	44-48	49-53	54-58	59-63
FORMER MODEL NUMBER	1HV	1 1/4HV	1 1/2HV	1 PR	60-1	60-2	60-3	60-4

SERIES 1050 CUSTOM BUILT CIRCULATORS

SIZE	5			
CATALOG MODEL NO.	1B	1 1/4B	1 1/2B	2B
FLANGE SIZE NPT (INCHES)	1	1 1/4	1 1/2	2
PARTS LIST PAGE NUMBER	64-68	69-73	74-78	79-83
FORMER MODEL NUMBER	1AA	1 1/4AA	1 1/2AA	2AA

STANDARD CIRCULATORS

SIZE	6
CATALOG MODEL NO.	S69
FLANGE SIZE NPT (INCHES)	3
PARTS LIST PAGE NUMBER	84-86
FORMER MODEL NUMBER	PD39

HIGH DUTY CIRCULATORS

SIZE	6					
CATALOG MODEL NO.	H63	H64	H65	H66	H67	H68
FLANGE SIZE NPT (INCHES)	1 1/2	1 1/2	1 1/2	2	2	2
PARTS LIST PAGE NUMBER	87-89	90-92	93-95	96-98	99-101	102-104
FORMER MODEL NUMBER	60-5	60-6	60-7	60-8	60-9	60-10

SERIES 1060 CUSTOM BUILT CIRCULATORS

SIZE	6					
CATALOG MODEL NO.	1 1/2D	2D	3D	3D	3D	3D
FLANGE SIZE NPT (INCHES)	1 1/2	2	3	3	3	3
PARTS LIST PAGE NUMBER	105-107	108-110	111-113			
FORMER MODEL NUMBER	1 1/2A	2A	S615	S610	S620	S630

CIRCULATOR PARTS

MODEL NUMBER S25 - SIZE 2 - Serial No. 6205 & Later			
STANDARD AND BRONZE FITTED CONSTRUCTION			
ITEM NO.	DESCRIPTION	PART NUMBER	ARMSTRONG BAR CODE
28	BODY GASKET	104442-000	
12	BRACKET HOUSING (2)	816958-111	
8	COUPLER ASSEMBLY (4 - Spring)	806026-001	
22	FACEPLATE	116077-071	
3	FLANGE - 3/4" NPT - CAST IRON	116013-011	
3	FLANGE - 1" NPT - CAST IRON	116012-011	
3	FLANGE - 1 1/4" NPT - CAST IRON	116011-011	
3	FLANGE - 1 1/2" NPT - CAST IRON	116009-011	
5	FLANGE BOLTS - 7/16-14X1 1/2	911123-112	
4	FLANGE GASKET	816653-000	
11	FLANGE NUTS - 7/16-14 JAM	911123-112	
2	IMPELLER	812961-111	
23	IMPELLER KEY (WOODRUFF #2)	974507-100	
27	IMPELLER NUT	913171-100	
26	IMPELLER WASHER	927311-100	
15	MECHANICAL SEAL ASSEMBLY	816706-021	
7	RESILIENT MTD. MOT. ASSY. - 1PH/1/12HP/115V	805316-010	
10	MOTOR CAPSCREWS - 1/4-20X5/8	911117-105	
17	O RING - MODULE	961131-036	
18	O RING - REAR BEARING	961131-024	
19	O RING - SHAFT	961131-013	
24	OIL SEAL	116975-000	
21	OIL WICK (BRIDGE)	116949-000	
20	OIL WICK (ROUND)	116948-000	
1	PUMP BODY	805482-011	
9	PUMP BODY CAPSCREWS- 3/8-16X7/8	911121-107	
29	SEAL BEARING ASSEMBLY (1)	810119-001	
16	SHAFT AND BEARING MODULE (3)	816999-071	

NOTES: (1) Seal Bearing Assembly includes Bearing Bracket, Body Gasket, Standard 812961-111 Impeller, Standard 106076-000 Impeller Nut, Standard 927411-700 Impeller Washer, Module, Impeller Key, "Armite" Seal Assembly, Ceramic Seal Seat, Buna "L" (retainer) Cup, and 5/8 Ounces of Oil.
(2) Includes Face Plate and Buna "N" Oil Seal
(3) Includes Front Sleeve Bearing, Shaft and Sleeve Assembly, two Oil Wicks, three "O" Rings, rear Sleeve Bearing Assembly, four Mounting Screws, Impeller Key, "Armite" Seal Assembly, Ceramic Seal Seat, Buna "L" (retainer) Cup and 5/8 ounces of oil.

CIRCULATOR PARTS

MODEL NUMBER S25 - SIZE 2 - Serial No. 6205 & Later			
ALL BRONZE CONSTRUCTION			
ITEM NO.	DESCRIPTION	PART NUMBER	ARMSTRONG BAR CODE
28	BODY GASKET	104442-000	
12	BRACKET HOUSING (2)	816958-111	
8	COUPLER ASSEMBLY (4 - Spring)	806026-001	
22	FACEPLATE	116077-071	
3	FLANGE - 3/4" NPT - BRONZE	116013-041	
3	FLANGE - 1" NPT - BRONZE	116012-041	
3	FLANGE - 1 1/4" NPT - BRONZE	116011-041	
3	FLANGE - 1 1/2" NPT - BRONZE	116009-041	
5	FLANGE BOLTS - 7/16-14X1 1/2	911123-112	
4	FLANGE GASKET	816653-000	
11	FLANGE NUTS - 7/16-14 JAM	913523-100	
2	IMPELLER	812961-111	
23	IMPELLER KEY (WOODRUFF #2)	974507-100	
27	IMPELLER NUT	106076-000	
26	IMPELLER WASHER	927411-700	
15	MECHANICAL SEAL ASSEMBLY	816706-021	
7	RESILIENT MTD. MOT. ASSY. - 1PH/1/12HP/115V	805316-010	
10	MOTOR CAPSCREWS - 1/4-20X5/8	911117-105	
17	O RING - MODULE	961131-036	
18	O RING - REAR BEARING	961131-024	
19	O RING - SHAFT	961131-013	
24	OIL SEAL	116975-000	
21	OIL WICK (BRIDGE)	116949-000	
20	OIL WICK (ROUND)	116948-000	
1	PUMP BODY	805482-041	
9	PUMP BODY CAPSCREWS- 3/8-16X7/8	911121-107	
29	SEAL BEARING ASSEMBLY (1)	810119-001	
16	SHAFT AND BEARING MODULE (3)	816999-041	

NOTES: (1) Seal Bearing Assembly includes Bearing Bracket, Body Gasket, Standard 812961-111 Impeller, Standard 106076-000 Impeller Nut, Standard 927411-700 Impeller Washer, Module Impeller Key, "Armite" Seal Assembly, Ceramic Seal Seat, Buna "L" (retainer) Cup, 5/8 Ounces of Oil.
 (2) Includes Face Plate and Buna "N" Oil Seal
 (3) Includes Front Sleeve Bearing, Shaft and Sleeve Assembly, two Oil Wicks, three "O" Rings, rear Sleeve Bearing Assembly, four Mounting Screws, Impeller Key, "Armite" Seal Assembly, Ceramic Seal Seat, Buna "L" (retainer) Cup, 5/8 ounces of oil.

CIRCULATOR PARTS

MODEL NUMBER S25 - SIZE 2 - Serial No. 6205 & Later			
HIGH TEMP. STANDARD CONSTRUCTION (225 - 275 DEG. F)			
ITEM	DESCRIPTION	PART NUMBER	ARMSTRONG BAR CODE
28	BODY GASKET	104442-000	
12	BRACKET HOUSING (2)	816958-111	
8	COUPLER ASSEMBLY (4 - Spring)	806026-001	
22	FACEPLATE	116077-071	
3	FLANGE - 3/4" NPT - CAST IRON	116013-011	
3	FLANGE - 1" NPT - CAST IRON	116012-011	
3	FLANGE - 1 1/4" NPT - CAST IRON	116011-011	
3	FLANGE - 1 1/2" NPT - CAST IRON	116009-011	
5	FLANGE BOLTS - 7/16-14X1 1/2	911123-112	
4	FLANGE GASKET	816653-000	
11	FLANGE NUTS - 7/16-14 JAM	913523-100	
2	IMPELLER (Steel) (4)	812961-011	
23	IMPELLER KEY (WOODRUFF #2)	974507-100	
27	IMPELLER NUT	106076-000	
26	IMPELLER WASHER	927411-700	
15	MECHANICAL SEAL ASSY. (Viton) (5)	816706-023	
7	RESILIENT MTD. MOT. ASSY. - 1PH/1/12HP/115V	805316-010	
10	MOTOR CAPSCREWS - 1/4-20X5/8	911117-105	
17	O RING - MODULE	961131-036	
18	O RING - REAR BEARING	961131-024	
19	O RING - SHAFT	961131-013	
24	OIL SEAL	116975-000	
21	OIL WICK (BRIDGE)	116949-000	
20	OIL WICK (ROUND)	116948-000	
1	PUMP BODY	805482-011	
9	PUMP BODY CAPSCREWS- 3/8-16X7/8	911121-107	
29	SEAL BEARING ASSEMBLY (1) & (5)	810119-001	
16	SHAFT AND BEARING MODULE (3) & (5)	816999-041	

- NOTES:** (1) Seal Bearing Assembly includes Bearing Bracket, Body Gasket, Standard 812961-111 Impeller, Standard 106076-000 Impeller Nut, Standard 927411-700 Impeller Washer, Module Impeller Key, "Armite" Seal Assembly, Ceramic Seal Seat, Buna "L" (retainer) Cup, 5/8 Ounces of Oil.
(2) Includes Face Plate and Buna "N" Oil Seal
(3) Includes Front Sleeve Bearing, Shaft and Sleeve Assembly, two Oil Wicks, three "O" Rings, rear Sleeve Bearing Assembly, four Mounting Screws, Impeller Key, "Armite" Seal Assembly, Ceramic Seal Seat, Buna "L" (retainer) Cup, 5/8 ounces of oil.
(4) The 812961-111 Impeller on the Universal SBA must be removed and replaced with a 812961-011 Impeller
(5) The 816706-021 Mechanical Seal on the Universal SBA and the Shaft & Bearing Module must be removed and replaced with a 816706-023 Viton High Temperature Mechanical Seal.

CIRCULATOR PARTS

MODEL NUMBER S25 - SIZE 2 - Serial No. 6205 & Later HIGH TEMP. BRONZE FITTED CONSTRUCTION (225 - 275 DEG. F)			
ITEM NO.	DESCRIPTION	PART NUMBER	ARMSTRONG BAR CODE
28	BODY GASKET	104442-000	
12	BRACKET HOUSING (2)	816958-111	
8	COUPLER ASSEMBLY (4 - Spring)	806026-001	
22	FACEPLATE	116077-071	
3	FLANGE - 3/4" NPT - CAST IRON	116013-011	
3	FLANGE - 1" NPT - CAST IRON	116012-011	
3	FLANGE - 1 1/4" NPT - CAST IRON	116011-011	
3	FLANGE - 1 1/2" NPT - CAST IRON	116009-011	
5	FLANGE BOLTS - 7/16-14X1 1/2	911123-112	
4	FLANGE GASKET	816653-000	
11	FLANGE NUTS - 7/16-14 JAM	913523-100	
2	IMPELLER (Brass) (4)	812961-041	
23	IMPELLER KEY (WOODRUFF #2)	974507-100	
27	IMPELLER NUT	106076-000	
26	IMPELLER WASHER	927411-700	
15	MECHANICAL SEAL ASSY. (Viton) (5)	816706-023	
7	RESILIENT MTD. MOT. ASSY. - 1PH/1/12HP/115V	805316-010	
10	MOTOR CAPSCREWS - 1/4-20X5/8	911117-105	
17	O RING - MODULE	961131-036	
18	O RING - REAR BEARING	961131-024	
19	O RING - SHAFT	961131-013	
24	OIL SEAL	116975-000	
21	OIL WICK (BRIDGE)	116949-000	
20	OIL WICK (ROUND)	116948-000	
1	PUMP BODY	805482-011	
9	PUMP BODY CAPSCREWS- 3/8-16X7/8	911121-107	
29	SEAL BEARING ASSEMBLY (1) & (5)	810119-001	
16	SHAFT AND BEARING MODULE (3) & (5)	816999-041	

- NOTES:** (1) Seal Bearing Assembly includes Bearing Bracket, Body Gasket, Standard 812961-111 Impeller, Standard 106076-000 Impeller Nut, Standard 927411-700 Impeller Washer, Module Impeller Key, "Armite" Seal Assembly, Ceramic Seal Seat, Buna "L" (retainer) Cup, 5/8 Ounces of Oil.
(2) Includes Face Plate and Buna "N" Oil Seal
(3) Includes Front Sleeve Bearing, Shaft and Sleeve Assembly, two Oil Wicks, three "O" Rings, rear Sleeve Bearing Assembly, four Mounting Screws, Impeller Key, "Armite" Seal Assembly, Ceramic Seal Seat, Buna "L" (retainer) Cup, 5/8 ounces of oil.
(4) The 812961-111 Impeller on the Universal SBA must be removed and replaced with a 812961-041 Impeller
(5) The 816706-021 Mechanical Seal on the Universal SBA and the Shaft & Bearing Module must be removed and replaced with a 816706-023 Viton High Temperature Mechanical Seal.

CIRCULATOR PARTS

MODEL NUMBER S25 - SIZE 2 - Serial No. 6205 & Later			
HIGH TEMP. ALL BRONZE CONSTRUCTION (225 - 275 DEG. F)			
ITEM NO.	DESCRIPTION	PART NUMBER	ARMSTRONG BAR CODE
28	BODY GASKET	104442-000	
12	BRACKET HOUSING (2)	816958-111	
8	COUPLER ASSEMBLY (4 - Spring)	806026-001	
22	FACEPLATE	116077-071	
3	FLANGE - 3/4" NPT - BRONZE	116013-041	
3	FLANGE - 1" NPT - BRONZE	116012-041	
3	FLANGE - 1 1/4" NPT - BRONZE	116011-041	
3	FLANGE - 1 1/2" NPT - BRONZE	116009-041	
5	FLANGE BOLTS - 7/16-14X1 1/2	911123-112	
4	FLANGE GASKET	816653-000	
11	FLANGE NUTS - 7/16-14 JAM	913523-100	
2	IMPELLER (Brass) (4)	812961-041	
23	IMPELLER KEY (WOODRUFF #2)	974507-100	
27	IMPELLER NUT	106076-000	
26	IMPELLER WASHER	927411-700	
15	MECHANICAL SEAL ASSY. (Viton) (5)	816706-023	
7	RESILIENT MTD. MOT. ASSY. - 1PH/1/12HP/115V	805316-010	
10	MOTOR CAPSCREWS - 1/4-20X5/8	911117-105	
17	O RING - MODULE	961131-036	
18	O RING - REAR BEARING	961131-024	
19	O RING - SHAFT	961131-013	
24	OIL SEAL	116975-000	
21	OIL WICK (BRIDGE)	116949-000	
20	OIL WICK (ROUND)	116948-000	
1	PUMP BODY	805482-041	
9	PUMP BODY CAPSCREWS- 3/8-16X7/8	911121-107	
29	SEAL BEARING ASSEMBLY (1) & (5)	810119-001	
16	SHAFT AND BEARING MODULE (3) & (5)	816999-041	

- NOTES:** (1) Seal Bearing Assembly includes Bearing Bracket, Body Gasket, Standard 812961-111 Impeller, Standard 106076-000 Impeller Nut, Standard 927411-700 Impeller Washer, Module Impeller Key, "Armite" Seal Assembly, Ceramic Seal Seat, Buna "L" (retainer) Cup, 5/8 Ounces of Oil.
 (2) Includes Face Plate and Buna "N" Oil Seal
 (3) Includes Front Sleeve Bearing, Shaft and Sleeve Assembly, two Oil Wicks, three "O" Rings, rear Sleeve Bearing Assembly, four Mounting Screws, Impeller Key, "Armite" Seal Assembly, Ceramic Seal Seat, Buna "L" (retainer) Cup, 5/8 ounces of oil.
 (4) The 812961-111 Impeller on the Universal SBA must be removed and replaced with a 812961-041 Impeller
 (5) The 816706-021 Mechanical Seal on the Universal SBA and the Shaft & Bearing Module must be removed and replaced with a 816706-023 Viton High Temperature Mechanical Seal.

CIRCULATOR PARTS

MODEL NUMBER H32 - SIZE 3 - Serial No. 6509 & Later			
STANDARD AND BRONZE FITTED CONSTRUCTION			
ITEM NO.	DESCRIPTION	PART NUMBER	ARMSTRONG BAR CODE
28	BODY GASKET	106049-000	
12	BRACKET HOUSING (2)	816961-111	
8	COUPLER ASSEMBLY (4 - Spring)	806026-001	
22	FACEPLATE	109522-071	
3	FLANGE - 1" NPT - CAST IRON	106073-011	
3	FLANGE - 1 1/4" NPT - CAST IRON	104300-011	
3	FLANGE - 1 1/2" NPT - CAST IRON	104301-011	
5	FLANGE BOLTS - 7/16-14X1 3/4	911123-114	
4	FLANGE GASKET (1990 & Later)	105176-000	
4	FLANGE GASKET (Prior to 1990)	104034-000	
11	FLANGE NUTS - 7/16-14 JAM	913523-100	
2	IMPELLER	816322-111	
23	IMPELLER KEY (WOODRUFF #2)	974507-100	
27	IMPELLER NUT	106076-000	
26	IMPELLER WASHER	927311-700	
15	MECHANICAL SEAL ASSEMBLY	816706-021	
7	RESILIENT MTD. MOT. ASSY. - 1PH1/6HP/115V	817025-001	
10	MOTOR CAPSCREWS - 5/16-18x1	911118-108	
17	O RING - MODULE	961131-036	
18	O RING - REAR BEARING	961131-024	
19	O RING - SHAFT	961131-013	
24	OIL SEAL	116975-000	
21	OIL WICK (BRIDGE)	116949-000	
20	OIL WICK (ROUND)	116948-000	
1	PUMP BODY	816402-011	
9	PUMP BODY CAPSCREWS - 7/16-14x1	911123-108	
29	SEAL BEARING ASSEMBLY (1)	810119-003	
29	SEAL BEARING ASSEMBLY (4)	816549-091	
16	SHAFT AND BEARING MODULE (3)	816999-041	

- NOTES:** (1) Seal Bearing Assembly includes Bearing Bracket, Body Gasket, Standard 816322-111 Impeller, Standard 106076-000 Impeller Nut, Standard 927411-700 Impeller Washer, Module, Impeller Key, "Armite" Seal Assembly, Ceramic Seal Seat, Buna "L" (retainer) Cup, and 5/8 Ounces of Oil.
- (2) Includes Face Plate and Buna "N" Oil Seal
- (3) Includes Front Sleeve Bearing, Shaft and Sleeve Assembly, two Oil Wicks, three "O" Rings, rear Sleeve Bearing Assembly, four Mounting Screws, Impeller Key, "Armite" Seal Assembly, Ceramic Seal Seat, Buna "L" (retainer) Cup and 5/8 ounces of oil.
- (4) Seal Bearing Assembly includes Bearing Bracket, Body Gasket, 106076-000 Impeller Nut, 927411-000, Module, Impeller Key, "Armite" Seal Assy., Ceramic Seal Seat, Buna "L" (retainer) Cup & 5/8oz. of Oil

CIRCULATOR PARTS

MODEL NUMBER H32 - SIZE 3 - Serial No. 6509 & Later ALL BRONZE CONSTRUCTION

ITEM NO.	DESCRIPTION	PART NUMBER	ARMSTRONG BAR CODE
28	BODY GASKET	106049-000	
12	BRACKET HOUSING (2)	816961-111	
8	COUPLER ASSEMBLY (4 - Spring)	806026-001	
22	FACEPLATE	109522-071	
3	FLANGE - 1" NPT - BRONZE	106073-041	
3	FLANGE - 1 1/4" NPT - BRONZE	104300-041	
3	FLANGE - 1 1/2" NPT - BRONZE	104301-041	
5	FLANGE BOLTS - 7/16-14X1 3/4	911123-114	
4	FLANGE GASKET (1990 & Later)	105176-000	
4	FLANGE GASKET (Prior to 1990)	104034-000	
11	FLANGE NUTS - 7/16-14 JAM	913523-100	
2	IMPELLER	816322-111	
23	IMPELLER KEY (WOODRUFF #2)	974507-100	
27	IMPELLER NUT	106076-000	
26	IMPELLER WASHER	927311-700	
15	MECHANICAL SEAL ASSEMBLY	816706-021	
7	RESILIENT MTD. MOT. ASSY. - 1PH/1/6HP/115V	817025-001	
10	MOTOR CAPSCREWS - 5/16-18x1	911118-108	
17	O RING - MODULE	961131-036	
18	O RING - REAR BEARING	961131-024	
19	O RING - SHAFT	961131-013	
24	OIL SEAL	116975-000	
21	OIL WICK (BRIDGE)	116949-000	
20	OIL WICK (ROUND)	116948-000	
1	PUMP BODY	816402-041	
9	PUMP BODY CAPSCREWS - 7/16-14x1	911123-108	
29	SEAL BEARING ASSEMBLY (1)	810119-003	
29	SEAL BEARING ASSEMBLY (4)	816549-091	
16	SHAFT AND BEARING MODULE (3)	816999-041	

- NOTES:** (1) Seal Bearing Assembly includes Bearing Bracket, Body Gasket, Standard 816322-111 Impeller, Standard 106076-000 Impeller Nut, Standard 927411-700 Impeller Washer, Module, Impeller Key, "Armite" Seal Assembly, Ceramic Seal Seat, Buna "L" (retainer) Cup, and 5/8 Ounces of Oil.
- (2) Includes Face Plate and Buna "N" Oil Seal
- (3) Includes Front Sleeve Bearing, Shaft and Sleeve Assembly, two Oil Wicks, three "O" Rings, rear Sleeve Bearing Assembly, four Mounting Screws, Impeller Key, "Armite" Seal Assembly, Ceramic Seal Seat, Buna "L" (retainer) Cup and 5/8 ounces of oil.
- (4) Seal Bearing Assembly includes Bearing Bracket, Body Gasket, 106076-000 Impeller Nut, 927411-000, Module, Impeller Key, "Armite" Seal Assy., Ceramic Seal Seat, Buna "L" (retainer) Cup & 5/8oz. of Oil

CIRCULATOR PARTS

MODEL NUMBER H32 - SIZE 3 - Serial No. 6509 & Later			
HIGH TEMP. STANDARD CONSTRUCTION (225 - 275 DEG. F)			
ITEM NO.	DESCRIPTION	PART NUMBER	ARMSTRONG BAR CODE
28	BODY GASKET	106049-000	
12	BRACKET HOUSING (2)	816961-111	
8	COUPLER ASSEMBLY (4 - Spring)	806026-001	
22	FACEPLATE	109522-071	
3	FLANGE - 1" NPT - CAST IRON	106073-011	
3	FLANGE - 1 1/4" NPT - CAST IRON	104300-011	
3	FLANGE - 1 1/2" NPT - CAST IRON	104301-011	
5	FLANGE BOLTS - 7/16-14X1 3/4	911123-114	
4	FLANGE GASKET (1990 & Later)	105176-000	
4	FLANGE GASKET (Prior to 1990)	104034-000	
11	FLANGE NUTS - 7/16-14 JAM	913523-100	
2	IMPELLER (Steel) (4)	816322-011	
23	IMPELLER KEY (WOODRUFF #2)	974507-100	
27	IMPELLER NUT	106076-000	
26	IMPELLER WASHER	927311-700	
15	MECHANICAL SEAL ASSY. (Viton)(5)	816706-023	
7	RESILIENT MTD. MOT. ASSY. - 1PH/1/6HP/115V	817025-001	
10	MOTOR CAPSCREWS - 5/16-18x1	911118-108	
17	O RING - MODULE	961131-036	
18	O RING - REAR BEARING	961131-024	
19	O RING - SHAFT	961131-013	
24	OIL SEAL	116975-000	
21	OIL WICK (BRIDGE)	116949-000	
20	OIL WICK (ROUND)	116948-000	
1	PUMP BODY	816402-011	
9	PUMP BODY CAPSCREWS - 7/16-14x1	911123-108	
29	SEAL BEARING ASSEMBLY (1) & (5)	810119-003	
29	SEAL BEARING ASSEMBLY (5) & (6)	816549-091	
16	SHAFT AND BEARING MODULE (3) & (5)	816999-041	

- NOTES:** (1) Seal Bearing Assembly includes Bearing Bracket, Body Gasket, Standard 816402-111 Impeller, Standard 106076-000 Impeller Nut, Standard 927411-700 Impeller Washer, Module Impeller Key, "Armite" Seal Assembly, Ceramic Seal Seat, Buna "L" (retainer) Cup, 5/8 Ounces of Oil.
- (2) Includes Face Plate and Buna "N" Oil Seal
- (3) Includes Front Sleeve Bearing, Shaft and Sleeve Assembly, two Oil Wicks, three "O" Rings, rear Sleeve Bearing Assembly, four Mounting Screws, Impeller Key, "Armite" Seal Assembly, Ceramic Seal Seat, Buna "L" (retainer) Cup, 5/8 ounces of oil.
- (4) The 816322-111 Impeller on the Universal SBA must be removed and replaced with a 816322-011 Impeller
- (5) The 816706-021 Mechanical Seal on the Universal SBA and the Shaft & Bearing Module must be removed and replaced with a 816706-023 Viton High Temperature Mechanical Seal.
- (6) Seal Bearing Assembly includes Bearing Bracket, Body Gasket, 106076-000 Impeller Nut, 927411-000, Module, Impeller Key, "Armite" Seal Assy., Ceramic Seal Seat, Buna "L" (retainer) Cup & 5/8oz. of Oil

CIRCULATOR PARTS

MODEL NUMBER H32 - SIZE 3 - Serial No. 6509 & Later			
HIGH TEMP. BRONZE FITTED CONSTRUCTION (225 - 275 DEG. F)			
ITEM NO.	DESCRIPTION	PART NUMBER	ARMSTRONG BAR CODE
28	BODY GASKET	106049-000	
12	BRACKET HOUSING (2)	816961-111	
8	COUPLER ASSEMBLY (4 - Spring)	806026-001	
22	FACEPLATE	109522-071	
3	FLANGE - 1" NPT - CAST IRON	106073-011	
3	FLANGE - 1 1/4" NPT - CAST IRON	104300-011	
3	FLANGE - 1 1/2" NPT - CAST IRON	104301-011	
5	FLANGE BOLTS - 7/16-14X1 3/4	911123-114	
4	FLANGE GASKET (1990 & Later)	105176-000	
4	FLANGE GASKET (Prior to 1990)	104034-000	
11	FLANGE NUTS - 7/16-14 JAM	913523-100	
2	IMPELLER (Brass) (4)	816322-041	
23	IMPELLER KEY (WOODRUFF #2)	974507-100	
27	IMPELLER NUT	106076-000	
26	IMPELLER WASHER	927311-700	
15	MECHANICAL SEAL ASSY. (Viton)(5)	816706-023	
7	RESILIENT MTD. MOT. ASSY. - 1PH/1/6HP/115V	817025-001	
10	MOTOR CAPSCREWS - 5/16-18x1	911118-108	
17	O RING - MODULE	961131-036	
18	O RING - REAR BEARING	961131-024	
19	O RING - SHAFT	961131-013	
24	OIL SEAL	116975-000	
21	OIL WICK (BRIDGE)	116949-000	
20	OIL WICK (ROUND)	116948-000	
1	PUMP BODY	816402-011	
9	PUMP BODY CAPSCREWS - 7/16-14x1	911123-108	
29	SEAL BEARING ASSEMBLY (1) & (5)	810119-003	
29	SEAL BEARING ASSEMBLY (5) & (6)	816549-091	
16	SHAFT AND BEARING MODULE (3) & (5)	816999-041	

- NOTES:** (1) Seal Bearing Assembly includes Bearing Bracket, Body Gasket, Standard 816402-111 Impeller, Standard 106076-000 Impeller Nut, Standard 927411-700 Impeller Washer, Module Impeller Key, "Armite" Seal Assembly, Ceramic Seal Seat, Buna "L" (retainer) Cup, 5/8 Ounces of Oil.
- (2) Includes Face Plate and Buna "N" Oil Seal
- (3) Includes Front Sleeve Bearing, Shaft and Sleeve Assembly, two Oil Wicks, three "O" Rings, rear Sleeve Bearing Assembly, four Mounting Screws, Impeller Key, "Armite" Seal Assembly, Ceramic Seal Seat, Buna "L" (retainer) Cup, 5/8 ounces of oil.
- (4) The 816322-111 Impeller on the Universal SBA must be removed and replaced with a 816322-011 Impeller
- (5) The 816706-021 Mechanical Seal on the Universal SBA and the Shaft & Bearing Module must be removed and replaced with a 816706-023 Viton High Temperature Mechanical Seal.
- (6) Seal Bearing Assembly includes Bearing Bracket, Body Gasket, 106076-000 Impeller Nut, 927411-000, Module, Impeller Key, "Armite" Seal Assy., Ceramic Seal Seat, Buna "L" (retainer) Cup & 5/8oz. of Oil

CIRCULATOR PARTS

MODEL NUMBER H32 - SIZE 3 - Serial No. 6509 & Later			
HIGH TEMP. ALL BRONZE CONSTRUCTION (225 - 275 DEG. F)			
ITEM NO.	DESCRIPTION	PART NUMBER	ARMSTRONG BAR CODE
28	BODY GASKET	106049-000	
12	BRACKET HOUSING (2)	816961-111	
8	COUPLER ASSEMBLY (4 - Spring)	806026-001	
22	FACEPLATE	109522-071	
3	FLANGE - 1" NPT - BRONZE	106073-041	
3	FLANGE - 1 1/4" NPT - BRONZE	104300-041	
3	FLANGE - 1 1/2" NPT - BRONZE	104301-041	
5	FLANGE BOLTS - 7/16-14X1 3/4	911123-114	
4	FLANGE GASKET (1990 & Later)	105176-000	
4	FLANGE GASKET (Prior to 1990)	104034-000	
11	FLANGE NUTS - 7/16-14 JAM	913523-100	
2	IMPELLER (Steel) (4)	816322-041	
23	IMPELLER KEY (WOODRUFF #2)	974507-100	
27	IMPELLER NUT	106076-000	
26	IMPELLER WASHER	927311-700	
15	MECHANICAL SEAL ASSY. (Viton)(5)	816706-023	
7	RESILIENT MTD. MOT. ASSY. - 1PH/1/6HP/115V	817025-001	
10	MOTOR CAPSCREWS - 5/16-18x1	911118-108	
17	O RING - MODULE	961131-036	
18	O RING - REAR BEARING	961131-024	
19	O RING - SHAFT	961131-013	
24	OIL SEAL	116975-000	
21	OIL WICK (BRIDGE)	116949-000	
20	OIL WICK (ROUND)	116948-000	
1	PUMP BODY	816402-041	
9	PUMP BODY CAPSCREWS - 7/16-14x1	911123-108	
29	SEAL BEARING ASSEMBLY (1) & (5)	810119-003	
29	SEAL BEARING ASSEMBLY (5) & (6)	816549-091	
16	SHAFT AND BEARING MODULE (3) & (5)	816999-041	

- NOTES:** (1) Seal Bearing Assembly includes Bearing Bracket, Body Gasket, Standard 816402-111 Impeller, Standard 106076-000 Impeller Nut, Standard 927411-700 Impeller Washer, Module Impeller Key, "Armite" Seal Assembly, Ceramic Seal Seat, Buna "L" (retainer) Cup, 5/8 Ounces of Oil.
- (2) Includes Face Plate and Buna "N" Oil Seal
- (3) Includes Front Sleeve Bearing, Shaft and Sleeve Assembly, two Oil Wicks, three "O" Rings, rear Sleeve Bearing Assembly, four Mounting Screws, Impeller Key, "Armite" Seal Assembly, Ceramic Seal Seat, Buna "L" (retainer) Cup, 5/8 ounces of oil.
- (4) The 816322-111 Impeller on the Universal SBA must be removed and replaced with a 816322-041 Impeller
- (5) The 816706-021 Mechanical Seal on the Universal SBA and the Shaft & Bearing Module must be removed and replaced with a 816706-023 Viton High Temperature Mechanical Seal.
- (6) Seal Bearing Assembly includes Bearing Bracket, Body Gasket, 106076-000 Impeller Nut, 927411-000, Module, Impeller Key, "Armite" Seal Assy., Ceramic Seal Seat, Buna "L" (retainer) Cup & 5/8oz. of Oil

CIRCULATOR PARTS

MODEL NUMBER S35 - SIZE 3 - Serial No. 6509 & Later			
STANDARD AND BRONZE FITTED CONSTRUCTION			
ITEM NO.	DESCRIPTION	PART NUMBER	ARMSTRONG BAR CODE
28	BODY GASKET	106049-000	
12	BRACKET HOUSING (2)	816961-111	
8	COUPLER ASSEMBLY (4 - Spring)	806026-001	
22	FACEPLATE	109522-071	
3	FLANGE - 2" NPT - CAST IRON	105210-011	
5	FLANGE BOLTS - 1/2-13X2 1/4	911123-114	
4	FLANGE GASKET (1990 & Later)	105209-002	
4	FLANGE GASKET (Prior to 1990)	105209-000	
11	FLANGE NUTS - 1/2-13	913125-100	
2	IMPELLER	816322-111	
23	IMPELLER KEY (WOODRUFF #2)	974507-100	
27	IMPELLER NUT	106076-000	
26	IMPELLER WASHER	927311-700	
15	MECHANICAL SEAL ASSEMBLY	816706-021	
7	RESILIENT MTD. MOT. ASSY. - 1PH/1/6HP/115V	817025-001	
10	MOTOR CAPSCREWS - 5/16-18x1	911118-108	
17	O RING - MODULE	961131-036	
18	O RING - REAR BEARING	961131-024	
19	O RING - SHAFT	961131-013	
24	OIL SEAL	116975-000	
21	OIL WICK (BRIDGE)	116949-000	
20	OIL WICK (ROUND)	116948-000	
1	PUMP BODY	816327-011	
9	PUMP BODY CAPSCREWS - 7/16-14x1	911123-108	
29	SEAL BEARING ASSEMBLY (1)	810119-003	
29	SEAL BEARING ASSEMBLY (4)	816549-091	
16	SHAFT AND BEARING MODULE (3)	816999-041	

- NOTES:** (1) Seal Bearing Assembly includes Bearing Bracket, Body Gasket, Standard 816322-111 Impeller, Standard 106076-000 Impeller Nut, Standard 927411-700 Impeller Washer, Module, Impeller Key, "Armite" Seal Assembly, Ceramic Seal Seat, Buna "L" (retainer) Cup, and 5/8 Ounces of Oil.
- (2) Includes Face Plate and Buna "N" Oil Seal
- (3) Includes Front Sleeve Bearing, Shaft and Sleeve Assembly, two Oil Wicks, three "O" Rings, rear Sleeve Bearing Assembly, four Mounting Screws, Impeller Key, "Armite" Seal Assembly, Ceramic Seal Seat, Buna "L" (retainer) Cup and 5/8 ounces of oil.
- (4) Seal Bearing Assembly includes Bearing Bracket, Body Gasket, 106076-000 Impeller Nut, 927411-000, Module, Impeller Key, "Armite" Seal Assy., Ceramic Seal Seat, Buna "L" (retainer) Cup & 5/8oz. of Oil

CIRCULATOR PARTS

MODEL NUMBER S35 - SIZE 3 - Serial No. 6509 & Later ALL BRONZE CONSTRUCTION

ITEM NO.	DESCRIPTION	PART NUMBER	ARMSTRONG BAR CODE
28	BODY GASKET	106049-000	
12	BRACKET HOUSING (2)	816961-111	
8	COUPLER ASSEMBLY (4 - Spring)	806026-001	
22	FACEPLATE	109522-071	
3	FLANGE - 2" NPT - BRONZE	105210-041	
5	FLANGE BOLTS - 1/2-13X2 1/4	911123-114	
4	FLANGE GASKET (1990 & Later)	105209-002	
4	FLANGE GASKET (Prior to 1990)	105209-000	
11	FLANGE NUTS - 1/2-13	913125-100	
2	IMPELLER	816322-111	
23	IMPELLER KEY (WOODRUFF #2)	974507-100	
27	IMPELLER NUT	106076-000	
26	IMPELLER WASHER	927311-700	
15	MECHANICAL SEAL ASSEMBLY (4)	816706-021	
7	RESILIENT MTD. MOT. ASSY. - 1PH/1/6HP/115V	817025-001	
10	MOTOR CAPSCREWS - 5/16-18x1	911118-108	
17	O RING - MODULE	961131-036	
18	O RING - REAR BEARING	961131-024	
19	O RING - SHAFT	961131-013	
24	OIL SEAL	116975-000	
21	OIL WICK (BRIDGE)	116949-000	
20	OIL WICK (ROUND)	116948-000	
1	PUMP BODY	816327-041	
9	PUMP BODY CAPSCREWS - 7/16-14x1	911123-108	
29	SEAL BEARING ASSEMBLY (1)	810119-003	
29	SEAL BEARING ASSEMBLY (4)	816549-091	
16	SHAFT AND BEARING MODULE (3)	816999-041	

- NOTES:** (1) Seal Bearing Assembly includes Bearing Bracket, Body Gasket, Standard 816322-111 Impeller, Standard 106076-000 Impeller Nut, Standard 927411-700 Impeller Washer, Module, Impeller Key, "Armite" Seal Assembly, Ceramic Seal Seat, Buna "L" (retainer) Cup, and 5/8 Ounces of Oil.
- (2) Includes Face Plate and Buna "N" Oil Seal
- (3) Includes Front Sleeve Bearing, Shaft and Sleeve Assembly, two Oil Wicks, three "O" Rings, rear Sleeve Bearing Assembly, four Mounting Screws, Impeller Key, "Armite" Seal Assembly, Ceramic Seal Seat, Buna "L" (retainer) Cup and 5/8 ounces of oil.
- (4) Seal Bearing Assembly includes Bearing Bracket, Body Gasket, 106076-000 Impeller Nut, 927411-000, Module, Impeller Key, "Armite" Seal Assy., Ceramic Seal Seat, Buna "L" (retainer) Cup & 5/8oz. of Oil

CIRCULATOR PARTS

MODEL NUMBER S35 - SIZE 3 - Serial No. 6509 & Later			
HIGH TEMP. STANDARD CONSTRUCTION (225 - 275 DEG. F)			
ITEM NO.	DESCRIPTION	PART NUMBER	ARMSTRONG BAR CODE
28	BODY GASKET	106049-000	
12	BRACKET HOUSING (2)	816961-111	
8	COUPLER ASSEMBLY (4 - Spring)	806026-001	
22	FACEPLATE	109522-071	
3	FLANGE - 2" NPT - CAST IRON	105210-011	
5	FLANGE BOLTS - 1/2-13X2 1/4	911123-114	
4	FLANGE GASKET (1990 & Later)	105209-002	
4	FLANGE GASKET (Prior to 1990)	105209-000	
11	FLANGE NUTS - 1/2-13	913125-100	
2	IMPELLER (Steel) (4)	816322-011	
23	IMPELLER KEY (WOODRUFF #2)	974507-100	
27	IMPELLER NUT	106076-000	
26	IMPELLER WASHER	927311-700	
15	MECHANICAL SEAL ASSY. (Viton) (5)	816706-023	
7	RESILIENT MTD. MOT. ASSY. - 1PH/1/6HP/115V	817025-001	
10	MOTOR CAPSCREWS - 5/16-18x1	911118-108	
17	O RING - MODULE	961131-036	
18	O RING - REAR BEARING	961131-024	
19	O RING - SHAFT	961131-013	
24	OIL SEAL	116975-000	
21	OIL WICK (BRIDGE)	116949-000	
20	OIL WICK (ROUND)	116948-000	
1	PUMP BODY	816327-011	
9	PUMP BODY CAPSCREWS - 7/16-14x1	911123-108	
29	SEAL BEARING ASSEMBLY (1) & (5)	810119-003	
29	SEAL BEARING ASSEMBLY (5) & (6)	816549-091	
16	SHAFT AND BEARING MODULE (3) & (5)	816999-041	

- NOTES:** (1) Seal Bearing Assembly includes Bearing Bracket, Body Gasket, Standard 816322-111 Impeller, Standard 106076-000 Impeller Nut, Standard 927411-700 Impeller Washer, Module, Impeller Key, "Armite" Seal Assembly, Ceramic Seal Seat, Buna "L" (retainer) Cup, and 5/8 Ounces of Oil.
(2) Includes Face Plate and Buna "N" Oil Seal
(3) Includes Front Sleeve Bearing, Shaft and Sleeve Assembly, two Oil Wicks, three "O" Rings, rear Sleeve Bearing Assembly, four Mounting Screws, Impeller Key, "Armite" Seal Assembly, Ceramic Seal Seat, Buna "L" (retainer) Cup and 5/8 ounces of oil.
(4) The 816322-111 Impeller on the Universal SBA must be removed and replaced with a 816322-011 Impeller
(5) The 816706-021 Mechanical Seal on the Universal SBA and the Shaft & Bearing Module must be removed and replaced with a 816706-023 Viton High Temperature Mechanical Seal.
(6) Seal Bearing Assembly includes Bearing Bracket, Body Gasket, 106076-000 Impeller Nut, 927411-000, Module, Impeller Key, "Armite" Seal Assy., Ceramic Seal Seat, Buna "L" (retainer) Cup & 5/8oz. of Oil

CIRCULATOR PARTS

MODEL NUMBER S35 - SIZE 3 - Serial No. 6509 & Later			
HIGH TEMP. BRONZE FITTED CONSTRUCTION (225 - 275 DEG. F)			
ITEM NO.	DESCRIPTION	PART NUMBER	ARMSTRONG BAR CODE
28	BODY GASKET	106049-000	
12	BRACKET HOUSING (2)	816961-111	
8	COUPLER ASSEMBLY (4 - Spring)	806026-001	
22	FACEPLATE	109522-071	
3	FLANGE - 2" NPT - CAST IRON	105210-011	
5	FLANGE BOLTS - 1/2-13X2 1/4	911123-114	
4	FLANGE GASKET (1990 & Later)	105209-002	
4	FLANGE GASKET (Prior to 1990)	105209-000	
11	FLANGE NUTS - 1/2-13	913125-100	
2	IMPELLER (Brass) (4)	816322-041	
23	IMPELLER KEY (WOODRUFF #2)	974507-100	
27	IMPELLER NUT	106076-000	
26	IMPELLER WASHER	927311-700	
15	MECHANICAL SEAL ASSY. (Viton) (5)	816706-023	
7	RESILIENT MTD. MOT. ASSY. - 1PH/1/6HP/115V	817025-001	
10	MOTOR CAPSCREWS - 5/16-18x1	911118-108	
17	O RING - MODULE	961131-036	
18	O RING - REAR BEARING	961131-024	
19	O RING - SHAFT	961131-013	
24	OIL SEAL	116975-000	
21	OIL WICK (BRIDGE)	116949-000	
20	OIL WICK (ROUND)	116948-000	
1	PUMP BODY	816327-011	
9	PUMP BODY CAPSCREWS - 7/16-14x1	911123-108	
29	SEAL BEARING ASSEMBLY (1) & (5)	810119-003	
29	SEAL BEARING ASSEMBLY (5) & (6)	816549-091	
16	SHAFT AND BEARING MODULE (3) & (5)	816999-041	

- NOTES:** (1) Seal Bearing Assembly includes Bearing Bracket, Body Gasket, Standard 816402-111 Impeller, Standard 106076-000 Impeller Nut, Standard 927411-700 Impeller Washer, Module Impeller Key, "Armite" Seal Assembly, Ceramic Seal Seat, Buna "L" (retainer) Cup, 5/8 Ounces of Oil.
- (2) Includes Face Plate and Buna "N" Oil Seal
- (3) Includes Front Sleeve Bearing, Shaft and Sleeve Assembly, two Oil Wicks, three "O" Rings, rear Sleeve Bearing Assembly, four Mounting Screws, Impeller Key, "Armite" Seal Assembly, Ceramic Seal Seat, Buna "L" (retainer) Cup, 5/8 ounces of oil.
- (4) The 816322-111 Impeller on the Universal SBA must be removed and replaced with a 816322-041 Impeller
- (5) The 816706-021 Mechanical Seal on the Universal SBA and the Shaft & Bearing Module must be removed and replaced with a 816706-023 Viton High Temperature Mechanical Seal.
- (6) Seal Bearing Assembly includes Bearing Bracket, Body Gasket, 106076-000 Impeller Nut, 927411-000, Module, Impeller Key, "Armite" Seal Assy., Ceramic Seal Seat, Buna "L" (retainer) Cup & 5/8oz. of Oil

CIRCULATOR PARTS

MODEL NUMBER S35 - SIZE 3 - Serial No. 6509 & Later			
HIGH TEMP. ALL BRONZE CONSTRUCTION (225 - 275 DEG. F)			
ITEM NO.	DESCRIPTION	PART NUMBER	ARMSTRONG BAR CODE
28	BODY GASKET	106049-000	
12	BRACKET HOUSING (2)	816961-111	
8	COUPLER ASSEMBLY (4 - Spring)	806026-001	
22	FACEPLATE	109522-071	
3	FLANGE - 2" NPT - BRONZE	105210-041	
5	FLANGE BOLTS - 1/2-13X2 1/4	911123-114	
4	FLANGE GASKET (1990 & Later)	105209-002	
4	FLANGE GASKET (Prior to 1990)	105209-000	
11	FLANGE NUTS - 1/2-13	913125-100	
2	IMPELLER (Steel) (4)	816322-041	
23	IMPELLER KEY (WOODRUFF #2)	974507-100	
27	IMPELLER NUT	106076-000	
26	IMPELLER WASHER	927311-700	
15	MECHANICAL SEAL ASSY. (Viton) (5)	816706-023	
7	RESILIENT MTD. MOT. ASSY. - 1PH/1/6HP/115V	817025-001	
10	MOTOR CAPSCREWS - 5/16-18x1	911118-108	
17	O RING - MODULE	961131-036	
18	O RING - REAR BEARING	961131-024	
19	O RING - SHAFT	961131-013	
24	OIL SEAL	116975-000	
21	OIL WICK (BRIDGE)	116949-000	
20	OIL WICK (ROUND)	116948-000	
1	PUMP BODY	816327-041	
9	PUMP BODY CAPSCREWS - 7/16-14x1	911123-108	
29	SEAL BEARING ASSEMBLY (1) & (5)	810119-003	
29	SEAL BEARING ASSEMBLY (5) & (6)	816549-091	
16	SHAFT AND BEARING MODULE (3) & (5)	816999-041	

- NOTES:** (1) Seal Bearing Assembly includes Bearing Bracket, Body Gasket, Standard 816402-111 Impeller, Standard 106076-000 Impeller Nut, Standard 927411-700 Impeller Washer, Module Impeller Key, "Armite" Seal Assembly, Ceramic Seal Seat, Buna "L" (retainer) Cup, 5/8 Ounces of Oil.
- (2) Includes Face Plate and Buna "N" Oil Seal
- (3) Includes Front Sleeve Bearing, Shaft and Sleeve Assembly, two Oil Wicks, three "O" Rings, rear Sleeve Bearing Assembly, four Mounting Screws, Impeller Key, "Armite" Seal Assembly, Ceramic Seal Seat, Buna "L" (retainer) Cup, 5/8 ounces of oil.
- (4) The 816322-111 Impeller on the Universal SBA must be removed and replaced with a 816322-041 Impeller
- (5) The 816706-021 Mechanical Seal on the Universal SBA and the Shaft & Bearing Module must be removed and replaced with a 816706-023 Viton High Temperature Mechanical Seal.
- (6) Seal Bearing Assembly includes Bearing Bracket, Body Gasket, 106076-000 Impeller Nut, 927411-000, Module, Impeller Key, "Armite" Seal Assy., Ceramic Seal Seat, Buna "L" (retainer) Cup & 5/8oz. of Oil

CIRCULATOR PARTS

MODEL NUMBER H41 - SIZE 4 - Serial No. 5710 & Later			
STANDARD AND BRONZE FITTED CONSTRUCTION			
ITEM NO.	DESCRIPTION	PART NUMBER	ARMSTRONG BAR CODE
28	BODY GASKET	106050-000	
12	BRACKET HOUSING (2)	816963-111	
8	COUPLER ASSEMBLY (4 - Spring)	806026-001	
22	FACEPLATE	116290-071	
3	FLANGE - 1" NPT - CAST IRON	116012-011	
5	FLANGE BOLTS - 7/16-14X1 3/4	911123-114	
4	FLANGE GASKET	105176-000	
11	FLANGE NUTS - 7/16-14	913125-100	
2	IMPELLER	116301-325	
23	IMPELLER KEY (WOODRUFF #2)	974507-100	
27	IMPELLER NUT	106076-000	
26	IMPELLER WASHER	927311-700	
15	MECHANICAL SEAL ASSEMBLY	816706-021	
7	RESILIENT MTD. MOT. ASSY. - 1PH/1/6HP/115V	817025-001	
10	MOTOR CAPSCREWS - 5/16-18x1	911118-108	
17	O RING - MODULE	961131-036	
18	O RING - REAR BEARING	961131-024	
19	O RING - SHAFT	961131-013	
24	OIL SEAL	116975-000	
21	OIL WICK (BRIDGE)	116949-000	
20	OIL WICK (ROUND)	116948-000	
1	PUMP BODY	811240-011	
9	PUMP BODY CAPSCREWS - 7/16-14x1	911123-108	
29	SEAL BEARING ASSEMBLY (1)	816027-002	
16	SHAFT AND BEARING MODULE (3)	816999-041	

- NOTES:** (1) Seal Bearing Assembly includes Bearing Bracket, Body Gasket, Standard 106076-000 Impeller Nut, Standard 927411-700 Impeller Washer, Module, Impeller Key, "Armité" Seal Assembly, Ceramic Seal Seat, Buna "L" (retainer) Cup, and 5/8 Ounces of Oil.
- (2) Includes Face Plate and Buna "N" Oil Seal
- (3) Includes Front Sleeve Bearing, Shaft and Sleeve Assembly, two Oil Wicks, three "O" Rings, rear Sleeve Bearing Assembly, four Mounting Screws, Impeller Key, "Armité" Seal Assembly, Ceramic Seal Seat, Buna "L" (retainer) Cup and 5/8 ounces of oil.

CIRCULATOR PARTS

MODEL NUMBER H41 - SIZE 4 - Serial No. 5710 & Later			
ALL BRONZE CONSTRUCTION			
ITEM NO.	DESCRIPTION	PART NUMBER	ARMSTRONG BAR CODE
28	BODY GASKET	106050-000	
12	BRACKET HOUSING (2)	816963-111	
8	COUPLER ASSEMBLY (4 - Spring)	806026-001	
22	FACEPLATE	116290-071	
3	FLANGE - 1" NPT - BRONZE	116012-041	
5	FLANGE BOLTS - 7/16-14X1 3/4	911123-114	
4	FLANGE GASKET	105176-000	
11	FLANGE NUTS - 7/16-14	913125-100	
2	IMPELLER	116301-325	
23	IMPELLER KEY (WOODRUFF #2)	974507-100	
27	IMPELLER NUT	106076-000	
26	IMPELLER WASHER	927311-700	
15	MECHANICAL SEAL ASSEMBLY	816706-021	
7	RESILIENT MTD. MOT. ASSY. - 1PH/1/6HP/115V	817025-001	
10	MOTOR CAPSCREWS - 5/16-18x1	911118-108	
17	O RING - MODULE	961131-036	
18	O RING - REAR BEARING	961131-024	
19	O RING - SHAFT	961131-013	
24	OIL SEAL	116975-000	
21	OIL WICK (BRIDGE)	116949-000	
20	OIL WICK (ROUND)	116948-000	
1	PUMP BODY	811240-041	
9	PUMP BODY CAPSCREWS - 7/16-14x1	911123-108	
29	SEAL BEARING ASSEMBLY (1)	816027-002	
16	SHAFT AND BEARING MODULE (3)	816999-041	

- NOTES:** (1) Seal Bearing Assembly includes Bearing Bracket, Body Gasket, Standard 106076-000 Impeller Nut, Standard 927411-700 Impeller Washer, Module, Impeller Key, "Armite" Seal Assembly, Ceramic Seal Seat, Buna "L" (retainer) Cup, and 5/8 Ounces of Oil.
- (2) Includes Face Plate and Buna "N" Oil Seal
- (3) Includes Front Sleeve Bearing, Shaft and Sleeve Assembly, two Oil Wicks, three "O" Rings, rear Sleeve Bearing Assembly, four Mounting Screws, Impeller Key, "Armite" Seal Assembly, Ceramic Seal Seat, Buna "L" (retainer) Cup and 5/8 ounces of oil.

CIRCULATOR PARTS

MODEL NUMBER H41 - SIZE 4 - Serial No. 5710 & Later			
HIGH TEMP. STANDARD CONSTRUCTION (225 - 275 DEG. F)			
ITEM NO.	DESCRIPTION	PART NUMBER	ARMSTRONG BAR CODE
28	BODY GASKET	106049-000	
12	BRACKET HOUSING (2)	816961-111	
8	COUPLER ASSEMBLY (4 - Spring)	806026-001	
22	FACEPLATE	109522-071	
3	FLANGE - 1" NPT - CAST IRON	116012-011	
5	FLANGE BOLTS - 7/16-14x1 1/4	911123-114	
4	FLANGE GASKET	105176-000	
11	FLANGE NUTS - 7/16-14	913125-100	
2	IMPELLER (Steel)	816301-025	
23	IMPELLER KEY (WOODRUFF #2)	974507-100	
27	IMPELLER NUT	106076-000	
26	IMPELLER WASHER	927311-700	
15	MECHANICAL SEAL ASSY. (Viton) (4)	816706-023	
7	RESILIENT MTD. MOT. ASSY. - 1PH/1/6HP/115V	817025-001	
10	MOTOR CAPSCREWS - 5/16-18x1	911118-108	
17	O RING - MODULE	961131-036	
18	O RING - REAR BEARING	961131-024	
19	O RING - SHAFT	961131-013	
24	OIL SEAL	116975-000	
21	OIL WICK (BRIDGE)	116949-000	
20	OIL WICK (ROUND)	116948-000	
1	PUMP BODY	816327-011	
9	PUMP BODY CAPSCREWS - 7/16-14x1	911123-108	
29	SEAL BEARING ASSEMBLY (1) & (4)	810119-003	
16	SHAFT AND BEARING MODULE (3) & (4)	816999-041	

- NOTES:** (1) Seal Bearing Assembly includes Bearing Bracket, Body Gasket, Standard 106076-000 Impeller Nut, Standard 927411-700 Impeller Washer, Module, Impeller Key, "Armité" Seal Assembly, Ceramic Seal Seat, Buna "L" (retainer) Cup, and 5/8 Ounces of Oil.
- (2) Includes Face Plate and Buna "N" Oil Seal
- (3) Includes Front Sleeve Bearing, Shaft and Sleeve Assembly, two Oil Wicks, three "O" Rings, rear Sleeve Bearing Assembly, four Mounting Screws, Impeller Key, "Armité" Seal Assembly, Ceramic Seal Seat, Buna "L" (retainer) Cup and 5/8 ounces of oil.
- (4) **The 816706-021 Mechanical Seal on the Universal SBA and the Shaft & Bearing Module must be removed and replaced with a 816706-023 Viton High Temperature Mechanical Seal.**

CIRCULATOR PARTS

MODEL NUMBER H41 - SIZE 4 - Serial No. 5710 & Later			
HIGH TEMP. BRONZE FITTED CONSTRUCTION (225 - 275 DEG. F)			
ITEM NO.	DESCRIPTION	PART NUMBER	ARMSTRONG BAR CODE
28	BODY GASKET	106049-000	
12	BRACKET HOUSING (2)	816961-111	
8	COUPLER ASSEMBLY (4 - Spring)	806026-001	
22	FACEPLATE	109522-071	
3	FLANGE - 1" NPT - CAST IRON	116012-011	
5	FLANGE BOLTS - 7/16-14x1 1/4	911123-114	
4	FLANGE GASKET	105176-000	
11	FLANGE NUTS - 7/16-14	913125-100	
2	IMPELLER (Brass)	816301-055	
23	IMPELLER KEY (WOODRUFF #2)	974507-100	
27	IMPELLER NUT	106076-000	
26	IMPELLER WASHER	927311-700	
15	MECHANICAL SEAL ASSY. (Viton) (4)	816706-023	
7	RESILIENT MTD. MOT. ASSY. - 1PH/1/6HP/115V	817025-001	
10	MOTOR CAPSCREWS - 5/16-18x1	911118-108	
17	O RING - MODULE	961131-036	
18	O RING - REAR BEARING	961131-024	
19	O RING - SHAFT	961131-013	
24	OIL SEAL	116975-000	
21	OIL WICK (BRIDGE)	116949-000	
20	OIL WICK (ROUND)	116948-000	
1	PUMP BODY	816327-011	
9	PUMP BODY CAPSCREWS - 7/16-14x1	911123-108	
29	SEAL BEARING ASSEMBLY (1) & (4)	810119-003	
16	SHAFT AND BEARING MODULE (3) & (4)	816999-041	

- NOTES:** (1) Seal Bearing Assembly includes Bearing Bracket, Body Gasket, Standard 106076-000 Impeller Nut, Standard 927411-700 Impeller Washer, Module, Impeller Key, "Armité" Seal Assembly, Ceramic Seal Seat, Buna "L" (retainer) Cup, and 5/8 Ounces of Oil.
- (2) Includes Face Plate and Buna "N" Oil Seal
- (3) Includes Front Sleeve Bearing, Shaft and Sleeve Assembly, two Oil Wicks, three "O" Rings, rear Sleeve Bearing Assembly, four Mounting Screws, Impeller Key, "Armité" Seal Assembly, Ceramic Seal Seat, Buna "L" (retainer) Cup and 5/8 ounces of oil.
- (4) **The 816706-021 Mechanical Seal on the Universal SBA and the Shaft & Bearing Module must be removed and replaced with a 816706-023 Viton High Temperature Mechanical Seal.**

CIRCULATOR PARTS

MODEL NUMBER H41 - SIZE 4 - Serial No. 5710 & Later			
HIGH TEMP. ALL BRONZE CONSTRUCTION (225 - 275 DEG. F)			
ITEM NO.	DESCRIPTION	PART NUMBER	ARMSTRONG BAR CODE
28	BODY GASKET	106049-000	
12	BRACKET HOUSING (2)	816961-111	
8	COUPLER ASSEMBLY (4 - Spring)	806026-001	
22	FACEPLATE	109522-071	
3	FLANGE -1" NPT - BRONZE	116012-041	
5	FLANGE BOLTS - 7/16-14x1 1/4	911123-114	
4	FLANGE GASKET	105176-000	
11	FLANGE NUTS - 7/16-14	913125-100	
2	IMPELLER (Brass)	816301-055	
23	IMPELLER KEY (WOODRUFF #2)	974507-100	
27	IMPELLER NUT	106076-000	
26	IMPELLER WASHER	927311-700	
15	MECHANICAL SEAL ASSY. (Viton) (4)	816706-023	
7	RESILIENT MTD. MOT. ASSY. - 1PH/1/6HP/115V	817025-001	
10	MOTOR CAPSCREWS - 5/16-18x1	911118-108	
17	O RING - MODULE	961131-036	
18	O RING - REAR BEARING	961131-024	
19	O RING - SHAFT	961131-013	
24	OIL SEAL	116975-000	
21	OIL WICK (BRIDGE)	116949-000	
20	OIL WICK (ROUND)	116948-000	
1	PUMP BODY	811240-041	
9	PUMP BODY CAPSCREWS - 7/16-14x1	911123-108	
29	SEAL BEARING ASSEMBLY (1) & (4)	810119-003	
16	SHAFT AND BEARING MODULE (3) & (4)	816999-041	

- NOTES:** (1) Seal Bearing Assembly includes Bearing Bracket, Body Gasket, Standard 106076-000 Impeller Nut, Standard 927411-700 Impeller Washer, Module, Impeller Key, "Armité" Seal Assembly, Ceramic Seal Seat, Buna "L" (retainer) Cup, and 5/8 Ounces of Oil.
- (2) Includes Face Plate and Buna "N" Oil Seal
- (3) Includes Front Sleeve Bearing, Shaft and Sleeve Assembly, two Oil Wicks, three "O" Rings, rear Sleeve Bearing Assembly, four Mounting Screws, Impeller Key, "Armité" Seal Assembly, Ceramic Seal Seat, Buna "L" (retainer) Cup and 5/8 ounces of oil.
- (4) **The 816706-021 Mechanical Seal on the Universal SBA and the Shaft & Bearing Module must be removed and replaced with a 816706-023 Viton High Temperature Mechanical Seal.**

CIRCULATOR PARTS

MODEL NUMBER S45 - SIZE 4 - Serial No. 5405 & Later			
STANDARD AND BRONZE FITTED CONSTRUCTION			
ITEM NO.	DESCRIPTION	PART NUMBER	ARMSTRONG BAR CODE
28	BODY GASKET	106050-000	
12	BRACKET HOUSING (2)	816963-111	
8	COUPLER ASSEMBLY (4 - Spring)	806168-001	
22	FACEPLATE	116290-071	
3	FLANGE - 2 1/2" NPT - CAST IRON	105189-011	
3	FLANGE - 3" NPT - CAST IRON	105188-011	
5	FLANGE BOLTS - 1/2-13x2 1/2	911125-120	
4	FLANGE GASKET	105201-000	
11	FLANGE NUTS - 1/2-13	913125-100	
2	IMPELLER	816305-328	
23	IMPELLER KEY (WOODRUFF #2)	974507-100	
27	IMPELLER NUT	106076-000	
26	IMPELLER WASHER	927311-700	
15	MECHANICAL SEAL ASSEMBLY	816706-021	
7	RESILIENT MTD. MOT. ASSY. - 1PH/1/4HP/115V	817025-007	
10	MOTOR CAPSCREWS - 5/16-18x1	911118-108	
17	O RING - MODULE	961131-036	
18	O RING - REAR BEARING	961131-024	
19	O RING - SHAFT	961131-013	
24	OIL SEAL	116975-000	
21	OIL WICK (BRIDGE)	116949-000	
20	OIL WICK (ROUND)	116948-000	
1	PUMP BODY	805484-011	
9	PUMP BODY CAPSCREWS - 7/16-14x1	911123-108	
29	SEAL BEARING ASSEMBLY (1)	816027-002	
16	SHAFT AND BEARING MODULE (3)	816999-041	

- NOTES:** (1) Seal Bearing Assembly includes Bearing Bracket, Body Gasket, Standard 106076-000 Impeller Nut, Standard 927411-700 Impeller Washer, Module, Impeller Key, "Armite" Seal Assembly, Ceramic Seal Seat, Buna "L" (retainer) Cup, and 5/8 Ounces of Oil.
- (2) Includes Face Plate and Buna "N" Oil Seal
- (3) Includes Front Sleeve Bearing, Shaft and Sleeve Assembly, two Oil Wicks, three "O" Rings, rear Sleeve Bearing Assembly, four Mounting Screws, Impeller Key, "Armite" Seal Assembly, Ceramic Seal Seat, Buna "L" (retainer) Cup and 5/8 ounces of oil.

CIRCULATOR PARTS

MODEL NUMBER S45 - SIZE 4 - Serial No. 5405 & Later ALL BRONZE CONSTRUCTION

ITEM NO.	DESCRIPTION	PART NUMBER	ARMSTRONG BAR CODE
28	BODY GASKET	106050-000	
12	BRACKET HOUSING (2)	816963-111	
8	COUPLER ASSEMBLY (4 - Spring)	806168-001	
22	FACEPLATE	116290-071	
3	FLANGE - 2 1/2" NPT - BRONZE	105189-041	
3	FLANGE - 3" NPT - BRONZE	105188-041	
5	FLANGE BOLTS - 1/2-13x2 1/2	911125-120	
4	FLANGE GASKET	105201-000	
11	FLANGE NUTS - 1/2-13	913125-100	
2	IMPELLER	816305-328	
23	IMPELLER KEY (WOODRUFF #2)	974507-100	
27	IMPELLER NUT	106076-000	
26	IMPELLER WASHER	927311-700	
15	MECHANICAL SEAL ASSEMBLY	816706-021	
7	RESILIENT MTD. MOT. ASSY. - 1PH/1/4HP/115V	817025-007	
10	MOTOR CAPSCREWS - 5/16-18x1	911118-108	
17	O RING - MODULE	961131-036	
18	O RING - REAR BEARING	961131-024	
19	O RING - SHAFT	961131-013	
24	OIL SEAL	116975-000	
21	OIL WICK (BRIDGE)	116949-000	
20	OIL WICK (ROUND)	116948-000	
1	PUMP BODY	805484-041	
9	PUMP BODY CAPSCREWS - 7/16-14x1	911123-108	
29	SEAL BEARING ASSEMBLY (1)	816027-002	
16	SHAFT AND BEARING MODULE (3)	816999-041	

- NOTES:** (1) Seal Bearing Assembly includes Bearing Bracket, Body Gasket, Standard 106076-000 Impeller Nut, Standard 927411-700 Impeller Washer, Module, Impeller Key, "Armite" Seal Assembly, Ceramic Seal Seat, Buna "L" (retainer) Cup, and 5/8 Ounces of Oil.
(2) Includes Face Plate and Buna "N" Oil Seal
(3) Includes Front Sleeve Bearing, Shaft and Sleeve Assembly, two Oil Wicks, three "O" Rings, rear Sleeve Bearing Assembly, four Mounting Screws, Impeller Key, "Armite" Seal Assembly, Ceramic Seal Seat, Buna "L" (retainer) Cup and 5/8 ounces of oil.

CIRCULATOR PARTS

MODEL NUMBER S45 - SIZE 4 - Serial No. 5405 & Later			
HIGH TEMP. STANDARD CONSTRUCTION (225 - 275 DEG. F)			
ITEM NO.	DESCRIPTION	PART NUMBER	ARMSTRONG BAR CODE
28	BODY GASKET	106050-000	
12	BRACKET HOUSING (2)	816963-111	
8	COUPLER ASSEMBLY (4 - Spring)	806168-001	
22	FACEPLATE	116290-071	
3	FLANGE - 2 1/2" NPT - CAST IRON	105189-011	
3	FLANGE - 3" NPT - CAST IRON	105188-011	
5	FLANGE BOLTS - 1/2-13x2 1/2	911125-120	
4	FLANGE GASKET	105176-000	
11	FLANGE NUTS - 1/2-13	913125-100	
2	IMPELLER	816305-028	
23	IMPELLER KEY (WOODRUFF #2)	974507-100	
27	IMPELLER NUT	106076-000	
26	IMPELLER WASHER	927311-700	
15	MECHANICAL SEAL ASSY. (Viton) (4)	816706-021	
7	RESILIENT MTD. MOT. ASSY. - 1PH/1/4HP/115V	817025-007	
10	MOTOR CAPSCREWS - 5/16-18x1	911118-108	
17	O RING - MODULE	961131-036	
18	O RING - REAR BEARING	961131-024	
19	O RING - SHAFT	961131-013	
24	OIL SEAL	116975-000	
21	OIL WICK (BRIDGE)	116949-000	
20	OIL WICK (ROUND)	116948-000	
1	PUMP BODY	805484-011	
9	PUMP BODY CAPSCREWS - 7/16-14x1	911123-108	
29	SEAL BEARING ASSEMBLY (1) & (4)	816027-002	
16	SHAFT AND BEARING MODULE (3) & (4)	816999-041	

- NOTES:** (1) Seal Bearing Assembly includes Bearing Bracket, Body Gasket, Standard 106076-000 Impeller Nut, Standard 927411-700 Impeller Washer, Module, Impeller Key, "Armite" Seal Assembly, Ceramic Seal Seat, Buna "L" (retainer) Cup, and 5/8 Ounces of Oil.
- (2) Includes Face Plate and Buna "N" Oil Seal
- (3) Includes Front Sleeve Bearing, Shaft and Sleeve Assembly, two Oil Wicks, three "O" Rings, rear Sleeve Bearing Assembly, four Mounting Screws, Impeller Key, "Armite" Seal Assembly, Ceramic Seal Seat, Buna "L" (retainer) Cup and 5/8 ounces of oil.
- (4) **The 816706-021 Mechanical Seal on the Universal SBA and the Shaft & Bearing Module must be removed and replaced with a 816706-023 Viton High Temperature Mechanical Seal.**

CIRCULATOR PARTS

MODEL NUMBER S45 - SIZE 4 - Serial No. 5405 & Later			
HIGH TEMP. BRONZE FITTED CONSTRUCTION (225 - 275 DEG. F)			
ITEM NO.	DESCRIPTION	PART NUMBER	ARMSTRONG BAR CODE
28	BODY GASKET	106050-000	
12	BRACKET HOUSING (2)	816963-111	
8	COUPLER ASSEMBLY (4 - Spring)	806168-001	
22	FACEPLATE	116290-071	
3	FLANGE - 2 1/2" NPT - CAST IRON	105189-011	
3	FLANGE - 3" NPT - CAST IRON	105188-011	
5	FLANGE BOLTS - 1/2-13x2 1/2	911125-120	
4	FLANGE GASKET	105176-000	
11	FLANGE NUTS - 1/2-13	913125-100	
2	IMPELLER	816305-058	
23	IMPELLER KEY (WOODRUFF #2)	974507-100	
27	IMPELLER NUT	106076-000	
26	IMPELLER WASHER	927311-700	
15	MECHANICAL SEAL ASSY. (Viton) (4)	816706-023	
7	RESILIENT MTD. MOT. ASSY. - 1PH/1/4HP/115V	817025-007	
10	MOTOR CAPSCREWS - 5/16-18x1	911118-108	
17	O RING - MODULE	961131-036	
18	O RING - REAR BEARING	961131-024	
19	O RING - SHAFT	961131-013	
24	OIL SEAL	116975-000	
21	OIL WICK (BRIDGE)	116949-000	
20	OIL WICK (ROUND)	116948-000	
1	PUMP BODY	805484-011	
9	PUMP BODY CAPSCREWS - 7/16-14x1	911123-108	
29	SEAL BEARING ASSEMBLY (1) & (4)	816027-002	
16	SHAFT AND BEARING MODULE (3) & (4)	816999-041	

- NOTES:** (1) Seal Bearing Assembly includes Bearing Bracket, Body Gasket, Standard 106076-000 Impeller Nut, Standard 927411-700 Impeller Washer, Module, Impeller Key, "Armite" Seal Assembly, Ceramic Seal Seat, Buna "L" (retainer) Cup, and 5/8 Ounces of Oil.
- (2) Includes Face Plate and Buna "N" Oil Seal
- (3) Includes Front Sleeve Bearing, Shaft and Sleeve Assembly, two Oil Wicks, three "O" Rings, rear Sleeve Bearing Assembly, four Mounting Screws, Impeller Key, "Armite" Seal Assembly, Ceramic Seal Seat, Buna "L" (retainer) Cup and 5/8 ounces of oil.
- (4) **The 816706-021 Mechanical Seal on the Universal SBA and the Shaft & Bearing Module must be removed and replaced with a 816706-023 Viton High Temperature Mechanical Seal.**

CIRCULATOR PARTS

MODEL NUMBER S45 - SIZE 4 - Serial No. 5405 & Later			
HIGH TEMP. ALL BRONZE CONSTRUCTION (225 - 275 DEG. F)			
ITEM NO.	DESCRIPTION	PART NUMBER	ARMSTRONG BAR CODE
28	BODY GASKET	106050-000	
12	BRACKET HOUSING (2)	816963-111	
8	COUPLER ASSEMBLY (4 - Spring)	806168-001	
22	FACEPLATE	116290-071	
3	FLANGE - 2 1/2" NPT - BRONZE	105189-041	
3	FLANGE - 3" NPT - BRONZE	105188-041	
5	FLANGE BOLTS - 1/2-13x2 1/2	911125-120	
4	FLANGE GASKET	105201-000	
11	FLANGE NUTS - 1/2-13	913125-100	
2	IMPELLER	816305-058	
23	IMPELLER KEY (WOODRUFF #2)	974507-100	
27	IMPELLER NUT	106076-000	
26	IMPELLER WASHER	927311-700	
15	MECHANICAL SEAL ASSY. (Viton) (4)	816706-023	
7	RESILIENT MTD. MOT. ASSY. - 1PH/1/4HP/115V	817025-007	
10	MOTOR CAPSCREWS - 5/16-18x1	911118-108	
17	O RING - MODULE	961131-036	
18	O RING - REAR BEARING	961131-024	
19	O RING - SHAFT	961131-013	
24	OIL SEAL	116975-000	
21	OIL WICK (BRIDGE)	116949-000	
20	OIL WICK (ROUND)	116948-000	
1	PUMP BODY	805484-041	
9	PUMP BODY CAPSCREWS - 7/16-14x1	911123-108	
29	SEAL BEARING ASSEMBLY (1) & (4)	816027-002	
16	SHAFT AND BEARING MODULE (3) & (4)	816999-041	

- NOTES:** (1) Seal Bearing Assembly includes Bearing Bracket, Body Gasket, Standard 106076-000 Impeller Nut, Standard 927411-700 Impeller Washer, Module, Impeller Key, "Armite" Seal Assembly, Ceramic Seal Seat, Buna "L" (retainer) Cup, and 5/8 Ounces of Oil.
- (2) Includes Face Plate and Buna "N" Oil Seal
- (3) Includes Front Sleeve Bearing, Shaft and Sleeve Assembly, two Oil Wicks, three "O" Rings, rear Sleeve Bearing Assembly, four Mounting Screws, Impeller Key, "Armite" Seal Assembly, Ceramic Seal Seat, Buna "L" (retainer) Cup and 5/8 ounces of oil.
- (4) **The 816706-021 Mechanical Seal on the Universal SBA and the Shaft & Bearing Module must be removed and replaced with a 816706-023 Viton High Temperature Mechanical Seal.**

CIRCULATOR PARTS

MODEL NUMBER S46 - SIZE 4 - Serial No. 5405 & Later			
STANDARD AND BRONZE FITTED CONSTRUCTION			
ITEM NO.	DESCRIPTION	PART NUMBER	ARMSTRONG BAR CODE
28	BODY GASKET	106050-000	
12	BRACKET HOUSING (2)	816963-111	
8	COUPLER ASSEMBLY (4 - Spring)	806168-001	
22	FACEPLATE	116290-071	
3	FLANGE - 3" NPT - CAST IRON	105188-011	
5	FLANGE BOLTS - 1/2-13x2 1/2	911125-120	
4	FLANGE GASKET	105201-000	
11	FLANGE NUTS - 1/2-13	913125-100	
2	IMPELLER	816305-325	
23	IMPELLER KEY (WOODRUFF #2)	974507-100	
27	IMPELLER NUT	106076-000	
26	IMPELLER WASHER	927311-700	
15	MECHANICAL SEAL ASSEMBLY	816706-021	
7	RESILIENT MTD. MOT. ASSY. - 1PH/1/3HP/115V	817025-013	
10	MOTOR CAPSCREWS - 5/16-18x1	911118-108	
17	O RING - MODULE	961131-036	
18	O RING - REAR BEARING	961131-024	
19	O RING - SHAFT	961131-013	
24	OIL SEAL	116975-000	
21	OIL WICK (BRIDGE)	116949-000	
20	OIL WICK (ROUND)	116948-000	
1	PUMP BODY	805484-011	
9	PUMP BODY CAPSCREWS - 7/16-14x1	911123-108	
29	SEAL BEARING ASSEMBLY (1)	816027-002	
16	SHAFT AND BEARING MODULE (3)	816999-041	

- NOTES:** (1) Seal Bearing Assembly includes Bearing Bracket, Body Gasket, Standard 106076-000 Impeller Nut, Standard 927411-700 Impeller Washer, Module, Impeller Key, "Armite" Seal Assembly, Ceramic Seal Seat, Buna "L" (retainer) Cup, and 5/8 Ounces of Oil.
- (2) Includes Face Plate and Buna "N" Oil Seal
- (3) Includes Front Sleeve Bearing, Shaft and Sleeve Assembly, two Oil Wicks, three "O" Rings, rear Sleeve Bearing Assembly, four Mounting Screws, Impeller Key, "Armite" Seal Assembly, Ceramic Seal Seat, Buna "L" (retainer) Cup and 5/8 ounces of oil.

CIRCULATOR PARTS

MODEL NUMBER S46 - SIZE 4 - Serial No. 5405 & Later ALL BRONZE CONSTRUCTION

ITEM NO.	DESCRIPTION	PART NUMBER	ARMSTRONG BAR CODE
28	BODY GASKET	106050-000	
12	BRACKET HOUSING (2)	816963-111	
8	COUPLER ASSEMBLY (4 - Spring)	806168-001	
22	FACEPLATE	116290-071	
3	FLANGE - 3" NPT - BRONZE	105188-041	
5	FLANGE BOLTS - 1/2-13x2 1/2	911125-120	
4	FLANGE GASKET	105201-000	
11	FLANGE NUTS - 1/2-13	913125-100	
2	IMPELLER	816305-325	
23	IMPELLER KEY (WOODRUFF #2)	974507-100	
27	IMPELLER NUT	106076-000	
26	IMPELLER WASHER	927311-700	
15	MECHANICAL SEAL ASSEMBLY	816706-021	
7	RESILIENT MTD. MOT. ASSY. - 1PH/1/3HP/115V	817025-013	
10	MOTOR CAPSCREWS - 5/16-18x1	911118-108	
17	O RING - MODULE	961131-036	
18	O RING - REAR BEARING	961131-024	
19	O RING - SHAFT	961131-013	
24	OIL SEAL	116975-000	
21	OIL WICK (BRIDGE)	116949-000	
20	OIL WICK (ROUND)	116948-000	
1	PUMP BODY	805484-041	
9	PUMP BODY CAPSCREWS - 7/16-14x1	911123-108	
29	SEAL BEARING ASSEMBLY (1)	816027-002	
16	SHAFT AND BEARING MODULE (3)	816999-041	

- NOTES:** (1) Seal Bearing Assembly includes Bearing Bracket, Body Gasket, Standard 106076-000 Impeller Nut, Standard 927411-700 Impeller Washer, Module, Impeller Key, "Armite" Seal Assembly, Ceramic Seal Seat, Buna "L" (retainer) Cup, and 5/8 Ounces of Oil.
- (2) Includes Face Plate and Buna "N" Oil Seal
- (3) Includes Front Sleeve Bearing, Shaft and Sleeve Assembly, two Oil Wicks, three "O" Rings, rear Sleeve Bearing Assembly, four Mounting Screws, Impeller Key, "Armite" Seal Assembly, Ceramic Seal Seat, Buna "L" (retainer) Cup and 5/8 ounces of oil.

CIRCULATOR PARTS

MODEL NUMBER S46 - SIZE 4 - Serial No. 5405 & Later			
HIGH TEMP. STANDARD CONSTRUCTION (225 - 275 DEG. F)			
ITEM NO.	DESCRIPTION	PART NUMBER	ARMSTRONG BAR CODE
28	BODY GASKET	106050-000	
12	BRACKET HOUSING (2)	816963-111	
8	COUPLER ASSEMBLY (4 - Spring)	806168-001	
22	FACEPLATE	116290-071	
3	FLANGE - 3" NPT - CAST IRON	105188-011	
5	FLANGE BOLTS - 1/2-13x2 1/2	911125-120	
4	FLANGE GASKET	105176-000	
11	FLANGE NUTS - 1/2-13	913125-100	
2	IMPELLER	816305-025	
23	IMPELLER KEY (WOODRUFF #2)	974507-100	
27	IMPELLER NUT	106076-000	
26	IMPELLER WASHER	927311-700	
15	MECHANICAL SEAL ASSY. (Viton) (4)	816706-021	
7	RESILIENT MTD. MOT. ASSY. - 1PH/1/3HP/115V	817025-013	
10	MOTOR CAPSCREWS - 5/16-18x1	911118-108	
17	O RING - MODULE	961131-036	
18	O RING - REAR BEARING	961131-024	
19	O RING - SHAFT	961131-013	
24	OIL SEAL	116975-000	
21	OIL WICK (BRIDGE)	116949-000	
20	OIL WICK (ROUND)	116948-000	
1	PUMP BODY	805484-011	
9	PUMP BODY CAPSCREWS - 7/16-14x1	911123-108	
29	SEAL BEARING ASSEMBLY (1) & (4)	816027-002	
16	SHAFT AND BEARING MODULE (3) & (4)	816999-041	

- NOTES:** (1) Seal Bearing Assembly includes Bearing Bracket, Body Gasket, Standard 106076-000 Impeller Nut, Standard 927411-700 Impeller Washer, Module, Impeller Key, "Armité" Seal Assembly, Ceramic Seal Seat, Buna "L" (retainer) Cup, and 5/8 Ounces of Oil.
- (2) Includes Face Plate and Buna "N" Oil Seal
- (3) Includes Front Sleeve Bearing, Shaft and Sleeve Assembly, two Oil Wicks, three "O" Rings, rear Sleeve Bearing Assembly, four Mounting Screws, Impeller Key, "Armité" Seal Assembly, Ceramic Seal Seat, Buna "L" (retainer) Cup and 5/8 ounces of oil.
- (4) **The 816706-021 Mechanical Seal on the Universal SBA and the Shaft & Bearing Module must be removed and replaced with a 816706-023 Viton High Temperature Mechanical Seal.**

CIRCULATOR PARTS

MODEL NUMBER S46 - SIZE 4 - Serial No. 5405 & Later			
HIGH TEMP. BRONZE FITTED CONSTRUCTION (225 - 275 DEG. F)			
ITEM NO.	DESCRIPTION	PART NUMBER	ARMSTRONG BAR CODE
28	BODY GASKET	106050-000	
12	BRACKET HOUSING (2)	816963-111	
8	COUPLER ASSEMBLY (4 - Spring)	806168-001	
22	FACEPLATE	116290-071	
3	FLANGE - 3" NPT - CAST IRON	105188-011	
5	FLANGE BOLTS - 1/2-13x2 1/2	911125-120	
4	FLANGE GASKET	105176-000	
11	FLANGE NUTS - 1/2-13	913125-100	
2	IMPELLER	816305-055	
23	IMPELLER KEY (WOODRUFF #2)	974507-100	
27	IMPELLER NUT	106076-000	
26	IMPELLER WASHER	927311-700	
15	MECHANICAL SEAL ASSY. (Viton) (4)	816706-023	
7	RESILIENT MTD. MOT. ASSY. - 1PH/1/3HP/115V	817025-013	
10	MOTOR CAPSCREWS - 5/16-18x1	911118-108	
17	O RING - MODULE	961131-036	
18	O RING - REAR BEARING	961131-024	
19	O RING - SHAFT	961131-013	
24	OIL SEAL	116975-000	
21	OIL WICK (BRIDGE)	116949-000	
20	OIL WICK (ROUND)	116948-000	
1	PUMP BODY	805484-011	
9	PUMP BODY CAPSCREWS - 7/16-14x1	911123-108	
29	SEAL BEARING ASSEMBLY (1) & (4)	816027-002	
16	SHAFT AND BEARING MODULE (3) & (4)	816999-041	

- NOTES:** (1) Seal Bearing Assembly includes Bearing Bracket, Body Gasket, Standard 106076-000 Impeller Nut, Standard 927411-700 Impeller Washer, Module, Impeller Key, "Armité" Seal Assembly, Ceramic Seal Seat, Buna "L" (retainer) Cup, and 5/8 Ounces of Oil.
- (2) Includes Face Plate and Buna "N" Oil Seal
- (3) Includes Front Sleeve Bearing, Shaft and Sleeve Assembly, two Oil Wicks, three "O" Rings, rear Sleeve Bearing Assembly, four Mounting Screws, Impeller Key, "Armité" Seal Assembly, Ceramic Seal Seat, Buna "L" (retainer) Cup and 5/8 ounces of oil.
- (4) The 816706-021 Mechanical Seal on the Universal SBA and the Shaft & Bearing Module must be removed and replaced with a 816706-023 Viton High Temperature Mechanical Seal.

CIRCULATOR PARTS

MODEL NUMBER S46 - SIZE 4 - Serial No. 5405 & Later			
HIGH TEMP. ALL BRONZE CONSTRUCTION (225 - 275 DEG. F)			
ITEM NO.	DESCRIPTION	PART NUMBER	ARMSTRONG BAR CODE
28	BODY GASKET	106050-000	
12	BRACKET HOUSING (2)	816963-111	
8	COUPLER ASSEMBLY (4 - Spring)	806168-001	
22	FACEPLATE	116290-071	
3	FLANGE - 2 1/2" NPT - BRONZE	105189-041	
3	FLANGE - 3" NPT - BRONZE	105188-041	
5	FLANGE BOLTS - 1/2-13x2 1/2	911125-120	
4	FLANGE GASKET	105201-000	
11	FLANGE NUTS - 1/2-13	913125-100	
2	IMPELLER	816305-055	
23	IMPELLER KEY (WOODRUFF #2)	974507-100	
27	IMPELLER NUT	106076-000	
26	IMPELLER WASHER	927311-700	
15	MECHANICAL SEAL ASSY. (Viton) (4)	816706-023	
7	RESILIENT MTD. MOT. ASSY. - 1PH/1/3HP/115V	817025-013	
10	MOTOR CAPSCREWS - 5/16-18x1	911118-108	
17	O RING - MODULE	961131-036	
18	O RING - REAR BEARING	961131-024	
19	O RING - SHAFT	961131-013	
24	OIL SEAL	116975-000	
21	OIL WICK (BRIDGE)	116949-000	
20	OIL WICK (ROUND)	116948-000	
1	PUMP BODY	805484-041	
9	PUMP BODY CAPSCREWS - 7/16-14x1	911123-108	
29	SEAL BEARING ASSEMBLY (1) & (4)	816027-002	
16	SHAFT AND BEARING MODULE (3) & (4)	816999-041	

- NOTES:** (1) Seal Bearing Assembly includes Bearing Bracket, Body Gasket, Standard 106076-000 Impeller Nut, Standard 927411-700 Impeller Washer, Module, Impeller Key, "Armite" Seal Assembly, Ceramic Seal Seat, Buna "L" (retainer) Cup, and 5/8 Ounces of Oil.
- (2) Includes Face Plate and Buna "N" Oil Seal
- (3) Includes Front Sleeve Bearing, Shaft and Sleeve Assembly, two Oil Wicks, three "O" Rings, rear Sleeve Bearing Assembly, four Mounting Screws, Impeller Key, "Armite" Seal Assembly, Ceramic Seal Seat, Buna "L" (retainer) Cup and 5/8 ounces of oil.
- (4) **The 816706-021 Mechanical Seal on the Universal SBA and the Shaft & Bearing Module must be removed and replaced with a 816706-023 Viton High Temperature Mechanical Seal.**

CIRCULATOR PARTS

MODEL NUMBER S55 - SIZE 5 - Serial No. 6104 & Later			
STANDARD AND BRONZE FITTED CONSTRUCTION			
ITEM NO.	DESCRIPTION	PART NUMBER	ARMSTRONG BAR CODE
28	BODY GASKET	106158-000	
12	BRACKET HOUSING (2)	816966-111	
8	COUPLER ASSEMBLY (Flexible)	806137-000	
0	COUPLER INSERT	875000-800	
22	FACEPLATE	174003-071	
3	FLANGE - 3" NPT - CAST IRON	105188-011	
5	FLANGE BOLTS - 1/2-13x2 1/2	911125-120	
4	FLANGE GASKET	105201-000	
11	FLANGE NUTS - 1/2-13	913125-100	
2	IMPELLER	816304-321	
23	IMPELLER KEY (WOODRUFF #2)	974507-100	
27	IMPELLER NUT	106076-000	
26	IMPELLER WASHER	927311-700	
15	MECHANICAL SEAL ASSEMBLY	816706-021	
7	RESILIENT MTD. MOT. ASSY. - 1PH/1/2HP/115/230V	811757-001	
7	RIGID MOUNT. MOT. ASSY. - 1PH /1/2HP/115/230	831009-062	
7	RIGID MOUNT. MOT. ASSY. - 3PH/1/2HP/208/230/460V(4)	831011-083	
7	RIGID MOUNT. MOT. ASSY. - 3PH/1/2HP/575V(4)	811757-004	
10	MOTOR CAPSCREWS - 3/8-16X3/4	911121-106	
17	O RING - MODULE	961131-036	
18	O RING - REAR BEARING	961131-024	
19	O RING - SHAFT	961131-013	
24	OIL SEAL	116975-000	
21	OIL WICK (BRIDGE)	116949-000	
20	OIL WICK (ROUND)	116948-000	
1	PUMP BODY	804133-011	
9	PUMP BODY CAPS. - 5/16-1/8x3/4	911123-108	
29	SEAL BEARING ASSEMBLY (1)	816032-000	
16	SHAFT AND BEARING MODULE (3)	816999-041	

NOTES: (1) Seal Bearing Assembly includes Bearing Bracket, Body Gasket, Standard 106076-000 Impeller Nut, Standard 927411-700 Impeller Washer, Module, Impeller Key, "Armitte" Seal Assembly, Ceramic Seal Seat, Buna "L" (retainer) Cup, and 5/8 Ounces of Oil.
 (2) Includes Face Plate and Buna "N" Oil Seal
 (3) Includes Front Sleeve Bearing, Shaft and Sleeve Assembly, two Oil Wicks, three "O" Rings, rear Sleeve Bearing Assembly, four Mounting Screws, Impeller Key, "Armitte" Seal Assembly, Ceramic Seal Seat, Buna "L" (retainer) Cup and 5/8 ounces of oil.

CIRCULATOR PARTS

MODEL NUMBER S55 - SIZE 5 - Serial No. 6104 & Later ALL BRONZE CONSTRUCTION

ITEM NO.	DESCRIPTION	PART NUMBER	ARMSTRONG BAR CODE
28	BODY GASKET	106158-000	
12	BRACKET HOUSING (2)	816966-111	
8	COUPLER ASSEMBLY	806137-000	
0	COUPLER INSERT	875000-800	
22	FACEPLATE	174003-071	
3	FLANGE - 3" NPT - BRONZE	105188-041	
5	FLANGE BOLTS - 1/2-13x2 1/2	911125-120	
4	FLANGE GASKET	105201-000	
11	FLANGE NUTS - 1/2-13	913125-100	
2	IMPELLER	816304-321	
23	IMPELLER KEY (WOODRUFF #2)	974507-100	
27	IMPELLER NUT	106076-000	
26	IMPELLER WASHER	927311-700	
15	MECHANICAL SEAL ASSEMBLY	816706-021	
7	RESILIENT MTD. MOT. ASSY. - 1PH/1/2HP/115/230V	811757-001	
7	RIGID MOUNT. MOT. ASSY. - 1PH /1/2HP/115/230	831009-062	
7	RIGID MOUNT. MOT. ASSY. - 3PH/1/2HP/208/230/460V(4)	831011-083	
7	RIGID MOUNT. MOT. ASSY. - 3PH/1/2HP/575V(4)	811757-004	
10	MOTOR CAPSCREWS - 3/8-16X3/4	911121-106	
17	O RING - MODULE	961131-036	
18	O RING - REAR BEARING	961131-024	
19	O RING - SHAFT	961131-013	
24	OIL SEAL	116975-000	
21	OIL WICK (BRIDGE)	116949-000	
20	OIL WICK (ROUND)	116948-000	
1	PUMP BODY	804133-041	
9	PUMP BODY CAPS. - 5/16-1/8x3/4	911123-108	
29	SEAL BEARING ASSEMBLY (1)	816032-000	
16	SHAFT AND BEARING MODULE (3)	816999-041	

- NOTES:** (1) Seal Bearing Assembly includes Bearing Bracket, Body Gasket, Standard 106076-000 Impeller Nut, Standard 927411-700 Impeller Washer, Module, Impeller Key, "Armité" Seal Assembly, Ceramic Seal Seat, Buna "L" (retainer) Cup, and 5/8 Ounces of Oil.
 (2) Includes Face Plate and Buna "N" Oil Seal
 (3) Includes Front Sleeve Bearing, Shaft and Sleeve Assembly, two Oil Wicks, three "O" Rings, rear Sleeve Bearing Assembly, four Mounting Screws, Impeller Key, "Armité" Seal Assembly, Ceramic Seal Seat, Buna "L" (retainer) Cup and 5/8 ounces of oil.

CIRCULATOR PARTS

MODEL NUMBER S55 - SIZE 5 - Serial No. 6104 & Later			
HIGH TEMP. STANDARD CONSTRUCTION (225 - 275 DEG. F)			
ITEM NO.	DESCRIPTION	PART NUMBER	ARMSTRONG BAR CODE
28	BODY GASKET	106158-000	
12	BRACKET HOUSING (2)	816966-111	
8	COUPLER ASSEMBLY (Flexible)	806137-000	
0	COUPLER INSERT	875000-800	
22	FACEPLATE	174003-071	
3	FLANGE - 3" NPT - CAST IRON	105188-011	
5	FLANGE BOLTS - 1/2-13x2 1/2	911125-120	
4	FLANGE GASKET	105201-000	
11	FLANGE NUTS - 1/2-13	913125-100	
2	IMPELLER	816304-021	
23	IMPELLER KEY (WOODRUFF #2)	974507-100	
27	IMPELLER NUT	106076-000	
26	IMPELLER WASHER	927311-700	
15	MECHANICAL SEAL ASSY. (Viton) (4)	816706-023	
7	RESILIENT MTD. MOT. ASSY. - 1PH/1/2HP/115/230V	811757-001	
7	RIGID MOUNT. MOT. ASSY. - 1PH /1/2HP/115/230	831009-062	
7	RIGID MOUNT. MOT. ASSY. - 3PH/1/2HP/208/230/460V(4)	831011-083	
7	RIGID MOUNT. MOT. ASSY. - 3PH/1/2HP/575V(4)	811757-004	
10	MOTOR CAPSCREWS - 3/8-16X3/4	911121-106	
17	O RING - MODULE	961131-036	
18	O RING - REAR BEARING	961131-024	
19	O RING - SHAFT	961131-013	
24	OIL SEAL	116975-000	
21	OIL WICK (BRIDGE)	116949-000	
20	OIL WICK (ROUND)	116948-000	
1	PUMP BODY	804133-011	
9	PUMP BODY CAPS. - 5/16-1/8x3/4	911123-108	
29	SEAL BEARING ASSEMBLY (1) & (4)	816032-000	
16	SHAFT AND BEARING MODULE (3) & (4)	816999-041	

- NOTES:** (1) Seal Bearing Assembly includes Bearing Bracket, Body Gasket, Standard 106076-000 Impeller Nut, Standard 927411-700 Impeller Washer, Module, Impeller Key, "Armitte" Seal Assembly, Ceramic Seal Seat, Buna "L" (retainer) Cup, and 5/8 Ounces of Oil.
- (2) Includes Face Plate and Buna "N" Oil Seal
- (3) Includes Front Sleeve Bearing, Shaft and Sleeve Assembly, two Oil Wicks, three "O" Rings, rear Sleeve Bearing Assembly, four Mounting Screws, Impeller Key, "Armitte" Seal Assembly, Ceramic Seal Seat, Buna "L" (retainer) Cup and 5/8 ounces of oil.
- (4) The 816706-021 Mechanical Seal on the Universal SBA and the Shaft & Bearing Module must be removed and replaced with a 816706-023 Viton High Temperature Mechanical Seal.

CIRCULATOR PARTS

MODEL NUMBER S55 - SIZE 5 - Serial No. 6104 & Later HIGH TEMP. BRONZE FITTED CONSTRUCTION (225 - 275 DEG. F)			
ITEM NO.	DESCRIPTION	PART NUMBER	ARMSTRONG BAR CODE
28	BODY GASKET	106158-000	
12	BRACKET HOUSING (2)	816966-111	
8	COUPLER ASSEMBLY (Flexible)	806137-000	
0	COUPLER INSERT	875000-800	
22	FACEPLATE	174003-071	
3	FLANGE - 3" NPT - CAST IRON	105188-011	
5	FLANGE BOLTS - 1/2-13x2 1/2	911125-120	
4	FLANGE GASKET	105201-000	
11	FLANGE NUTS - 1/2-13	913125-100	
2	IMPELLER	816304-051	
23	IMPELLER KEY (WOODRUFF #2)	974507-100	
27	IMPELLER NUT	106076-000	
26	IMPELLER WASHER	927311-700	
15	MECHANICAL SEAL ASSY. (Viton) (4)	816706-023	
7	RESILIENT MTD. MOT. ASSY. - 1PH/1/2HP/115/230V	811757-001	
7	RIGID MOUNT. MOT. ASSY. - 1PH /1/2HP/115/230	831009-062	
7	RIGID MOUNT. MOT. ASSY. - 3PH/1/2HP/208/230/460V(4)	831011-083	
7	RIGID MOUNT. MOT. ASSY. - 3PH/1/2HP/575V(4)	811757-004	
10	MOTOR CAPSCREWS - 3/8-16X3/4	911121-106	
17	O RING - MODULE	961131-036	
18	O RING - REAR BEARING	961131-024	
19	O RING - SHAFT	961131-013	
24	OIL SEAL	116975-000	
21	OIL WICK (BRIDGE)	116949-000	
20	OIL WICK (ROUND)	116948-000	
1	PUMP BODY	804133-011	
9	PUMP BODY CAPS. - 5/16-1/8x3/4	911123-108	
29	SEAL BEARING ASSEMBLY (1) & (4)	816032-000	
16	SHAFT AND BEARING MODULE (3) & (4)	816999-041	

- NOTES:** (1) Seal Bearing Assembly includes Bearing Bracket, Body Gasket, Standard 106076-000 Impeller Nut, Standard 927411-700 Impeller Washer, Module, Impeller Key, "Armité" Seal Assembly, Ceramic Seal Seat, Buna "L" (retainer) Cup, and 5/8 Ounces of Oil.
(2) Includes Face Plate and Buna "N" Oil Seal
(3) Includes Front Sleeve Bearing, Shaft and Sleeve Assembly, two Oil Wicks, three "O" Rings, rear Sleeve Bearing Assembly, four Mounting Screws, Impeller Key, "Armité" Seal Assembly, Ceramic Seal Seat, Buna "L" (retainer) Cup and 5/8 ounces of oil.
(4) **The 816706-021 Mechanical Seal on the Universal SBA and the Shaft & Bearing Module must be removed and replaced with a 816706-023 Viton High Temperature Mechanical Seal.**

CIRCULATOR PARTS

MODEL NUMBER S55 - SIZE 5 - Serial No. 6104 & Later			
HIGH TEMP. ALL BRONZE CONSTRUCTION (225 - 275 DEG. F)			
ITEM NO.	DESCRIPTION	PART NUMBER	ARMSTRONG BAR CODE
28	BODY GASKET	106158-000	
12	BRACKET HOUSING (2)	816966-111	
8	COUPLER ASSEMBLY (Flexible)	806137-000	
0	COUPLER INSERT	875000-800	
22	FACEPLATE	174003-071	
3	FLANGE - 3" NPT - CAST IRON	105188-011	
5	FLANGE BOLTS - 1/2-13x2 1/2	911125-120	
4	FLANGE GASKET	105201-000	
11	FLANGE NUTS - 1/2-13	913125-100	
2	IMPELLER	816304-051	
23	IMPELLER KEY (WOODRUFF #2)	974507-100	
27	IMPELLER NUT	106076-000	
26	IMPELLER WASHER	927311-700	
15	MECHANICAL SEAL ASSY. (Viton) (4)	816706-021	
7	RESILIENT MTD. MOT. ASSY. - 1PH/1/2HP/115/230V	811757-001	
7	RIGID MOUNT. MOT. ASSY. - 1PH /1/2HP/115/230	831009-062	
7	RIGID MOUNT. MOT. ASSY. - 3PH/1/2HP/208/230/460V(4)	831011-083	
7	RIGID MOUNT. MOT. ASSY. - 3PH/1/2HP/575V(4)	811757-004	
10	MOTOR CAPSCREWS - 3/8-16X3/4	911121-106	
17	O RING - MODULE	961131-036	
18	O RING - REAR BEARING	961131-024	
19	O RING - SHAFT	961131-013	
24	OIL SEAL	116975-000	
21	OIL WICK (BRIDGE)	116949-000	
20	OIL WICK (ROUND)	116948-000	
1	PUMP BODY	804133-041	
9	PUMP BODY CAPS. - 5/16-1/8x3/4	911123-108	
29	SEAL BEARING ASSEMBLY (1) & (4)	816032-000	
16	SHAFT AND BEARING MODULE (3) & (4)	816999-041	

- NOTES:** (1) Seal Bearing Assembly includes Bearing Bracket, Body Gasket, Standard 106076-000 Impeller Nut, Standard 927411-700 Impeller Washer, Module, Impeller Key, "Armitte" Seal Assembly, Ceramic Seal Seat, Buna "L" (retainer) Cup, and 5/8 Ounces of Oil.
- (2) Includes Face Plate and Buna "N" Oil Seal
- (3) Includes Front Sleeve Bearing, Shaft and Sleeve Assembly, two Oil Wicks, three "O" Rings, rear Sleeve Bearing Assembly, four Mounting Screws, Impeller Key, "Armitte" Seal Assembly, Ceramic Seal Seat, Buna "L" (retainer) Cup and 5/8 ounces of oil.
- (4) **The 816706-021 Mechanical Seal on the Universal SBA and the Shaft & Bearing Module must be removed and replaced with a 816706-023 Viton High Temperature Mechanical Seal.**

CIRCULATOR PARTS

MODEL NUMBER S57 - SIZE 5 - Serial No. 6104 & Later STANDARD AND BRONZE FITTED CONSTRUCTION

ITEM NO.	DESCRIPTION	PART NUMBER	ARMSTRONG BAR CODE
28	BODY GASKET	106158-000	
12	BRACKET HOUSING (2)	816966-111	
8	COUPLER ASSEMBLY (Flexible)	806137-000	
0	COUPLER INSERT	875000-800	
22	FACEPLATE	174003-071	
3	FLANGE - 3" NPT - CAST IRON	105188-011	
5	FLANGE BOLTS - 1/2-13x2 1/2	911125-120	
4	FLANGE GASKET	105201-000	
11	FLANGE NUTS - 1/2-13	913125-100	
2	IMPELLER	816304-317	
23	IMPELLER KEY (WOODRUFF #2)	974507-100	
27	IMPELLER NUT	106076-000	
26	IMPELLER WASHER	927311-700	
15	MECHANICAL SEAL ASSEMBLY	816706-021	
7	RESILIENT MTD. MOT. ASSY. - 1PH/3/4HP/115/230V	811757-002	
7	RIGID MOUNT. MOT. ASSY. - 1PH/3/4HP/115/230V	831010-062	
7	RIGID MOUNT. MOT. ASSY. - 3PH/3/4HP/208/230/460V(4)	831012-083	
7	RIGID MOUNT. MOT. ASSY. - 3PH/3/4HP/575V(4)	811757-006	
10	MOTOR CAPSCREWS - 3/8-16X3/4	911121-106	
17	O RING - MODULE	961131-036	
18	O RING - REAR BEARING	961131-024	
19	O RING - SHAFT	961131-013	
24	OIL SEAL	116975-000	
21	OIL WICK (BRIDGE)	116949-000	
20	OIL WICK (ROUND)	116948-000	
1	PUMP BODY	804133-011	
9	PUMP BODY CAPS. - 5/16-1/8x3/4	911123-108	
29	SEAL BEARING ASSEMBLY (1)	816032-000	
16	SHAFT AND BEARING MODULE (3)	816999-041	

- NOTES:** (1) Seal Bearing Assembly includes Bearing Bracket, Body Gasket, Standard 106076-000 Impeller Nut, Standard 927411-700 Impeller Washer, Module, Impeller Key, "Armitte" Seal Assembly, Ceramic Seal Seat, Buna "L" (retainer) Cup, and 5/8 Ounces of Oil.
(2) Includes Face Plate and Buna "N" Oil Seal
(3) Includes Front Sleeve Bearing, Shaft and Sleeve Assembly, two Oil Wicks, three "O" Rings, rear Sleeve Bearing Assembly, four Mounting Screws, Impeller Key, "Armitte" Seal Assembly, Ceramic Seal Seat, Buna "L" (retainer) Cup and 5/8 ounces of oil.

CIRCULATOR PARTS

MODEL NUMBER S57 - SIZE 5 - Serial No. 6104 & Later ALL BRONZE CONSTRUCTION

ITEM NO.	DESCRIPTION	PART NUMBER	ARMSTRONG BAR CODE
28	BODY GASKET	106158-000	
12	BRACKET HOUSING (2)	816966-111	
8	COUPLER ASSEMBLY	806137-000	
0	COUPLER INSERT	875000-800	
22	FACEPLATE	174003-071	
3	FLANGE - 3" NPT - BRONZE	105188-041	
5	FLANGE BOLTS - 1/2-13x2 1/2	911125-120	
4	FLANGE GASKET	105201-000	
11	FLANGE NUTS - 1/2-13	913125-100	
2	IMPELLER	816304-317	
23	IMPELLER KEY (WOODRUFF #2)	974507-100	
27	IMPELLER NUT	106076-000	
26	IMPELLER WASHER	927311-700	
15	MECHANICAL SEAL ASSEMBLY	816706-021	
7	RESILIENT MTD. MOT. ASSY. - 1PH/3/4HP/115/230V	811757-002	
7	RIGID MOUNT. MOT. ASSY. - 1PH/3/4HP/115/230V	831010-062	
7	RIGID MOUNT. MOT. ASSY. - 3PH/3/4HP/208/230/460V(4)	831012-083	
7	RIGID MOUNT. MOT. ASSY. - 3PH/3/4HP/575V(4)	811757-006	
10	MOTOR CAPSCREWS - 3/8-16X3/4	911121-106	
17	O RING - MODULE	961131-036	
18	O RING - REAR BEARING	961131-024	
19	O RING - SHAFT	961131-013	
24	OIL SEAL	116975-000	
21	OIL WICK (BRIDGE)	116949-000	
20	OIL WICK (ROUND)	116948-000	
1	PUMP BODY	804133-041	
9	PUMP BODY CAPS. - 5/16-1/8x3/4	911123-108	
29	SEAL BEARING ASSEMBLY (1)	816032-000	
16	SHAFT AND BEARING MODULE (3)	816999-041	

- NOTES:** (1) Seal Bearing Assembly includes Bearing Bracket, Body Gasket, Standard 106076-000 Impeller Nut, Standard 927411-700 Impeller Washer, Module, Impeller Key, "Armité" Seal Assembly, Ceramic Seal Seat, Buna "L" (retainer) Cup, and 5/8 Ounces of Oil.
(2) Includes Face Plate and Buna "N" Oil Seal
(3) Includes Front Sleeve Bearing, Shaft and Sleeve Assembly, two Oil Wicks, three "O" Rings, rear Sleeve Bearing Assembly, four Mounting Screws, Impeller Key, "Armité" Seal Assembly, Ceramic Seal Seat, Buna "L" (retainer) Cup and 5/8 ounces of oil.

CIRCULATOR PARTS

MODEL NUMBER S57 - SIZE 5 - Serial No. 6104 & Later			
HIGH TEMP. STANDARD CONSTRUCTION (225 - 275 DEG. F)			
ITEM NO.	DESCRIPTION	PART NUMBER	ARMSTRONG BAR CODE
28	BODY GASKET	106158-000	
12	BRACKET HOUSING (2)	816966-111	
8	COUPLER ASSEMBLY (Flexible)	806137-000	
0	COUPLER INSERT	875000-800	
22	FACEPLATE	174003-071	
3	FLANGE - 3" NPT - CAST IRON	105188-011	
5	FLANGE BOLTS - 1/2-13x2 1/2	911125-120	
4	FLANGE GASKET	105201-000	
11	FLANGE NUTS - 1/2-13	913125-100	
2	IMPELLER	816304-017	
23	IMPELLER KEY (WOODRUFF #2)	974507-100	
27	IMPELLER NUT	106076-000	
26	IMPELLER WASHER	927311-700	
15	MECHANICAL SEAL ASSY. (Viton) (4)	816706-023	
7	RESILIENT MTD. MOT. ASSY. - 1PH/3/4HP/115/230V	811757-002	
7	RIGID MOUNT. MOT. ASSY. - 1PH/3/4HP/115/230V	831010-062	
7	RIGID MOUNT. MOT. ASSY. - 3PH/3/4HP/208/230/460V(4)	831012-083	
7	RIGID MOUNT. MOT. ASSY. - 3PH/3/4HP/575V(4)	811757-006	
10	MOTOR CAPSCREWS - 3/8-16X3/4	911121-106	
17	O RING - MODULE	961131-036	
18	O RING - REAR BEARING	961131-024	
19	O RING - SHAFT	961131-013	
24	OIL SEAL	116975-000	
21	OIL WICK (BRIDGE)	116949-000	
20	OIL WICK (ROUND)	116948-000	
1	PUMP BODY	804133-011	
9	PUMP BODY CAPS. - 5/16-1/8x3/4	911123-108	
29	SEAL BEARING ASSEMBLY (1) & (4)	816032-000	
16	SHAFT AND BEARING MODULE (3) & (4)	816999-041	

- NOTES:** (1) Seal Bearing Assembly includes Bearing Bracket, Body Gasket, Standard 106076-000 Impeller Nut, Standard 927411-700 Impeller Washer, Module, Impeller Key, "Armité" Seal Assembly, Ceramic Seal Seat, Buna "L" (retainer) Cup, and 5/8 Ounces of Oil.
- (2) Includes Face Plate and Buna "N" Oil Seal
- (3) Includes Front Sleeve Bearing, Shaft and Sleeve Assembly, two Oil Wicks, three "O" Rings, rear Sleeve Bearing Assembly, four Mounting Screws, Impeller Key, "Armité" Seal Assembly, Ceramic Seal Seat, Buna "L" (retainer) Cup and 5/8 ounces of oil.
- (4) The 816706-021 Mechanical Seal on the Universal SBA and the Shaft & Bearing Module must be removed and replaced with a 816706-023 Viton High Temperature Mechanical Seal.
- (5) For TEFC or Explosion Proof Motors, please contact the factory.

CIRCULATOR PARTS

MODEL NUMBER S57 - SIZE 5 - Serial No. 6104 & Later HIGH TEMP. BRONZE FITTED CONSTRUCTION (225 - 275 DEG. F)

ITEM NO.	DESCRIPTION	PART NUMBER	ARMSTRONG BAR CODE
28	BODY GASKET	106158-000	
12	BRACKET HOUSING (2)	816966-111	
8	COUPLER ASSEMBLY (Flexible)	806137-000	
0	COUPLER INSERT	875000-800	
22	FACEPLATE	174003-071	
3	FLANGE - 3" NPT - CAST IRON	105188-011	
5	FLANGE BOLTS - 1/2-13x2 1/2	911125-120	
4	FLANGE GASKET	105201-000	
11	FLANGE NUTS - 1/2-13	913125-100	
2	IMPELLER	816304-047	
23	IMPELLER KEY (WOODRUFF #2)	974507-100	
27	IMPELLER NUT	106076-000	
26	IMPELLER WASHER	927311-700	
15	MECHANICAL SEAL ASSY. (Viton) (4)	816706-023	
7	RESILIENT MTD. MOT. ASSY. - 1PH/3/4HP/115/230V	811757-002	
7	RIGID MOUNT. MOT. ASSY. - 1PH/3/4HP/115/230V	831010-062	
7	RIGID MOUNT. MOT. ASSY. - 3PH/3/4HP/208/230/460V(4)	831012-083	
7	RIGID MOUNT. MOT. ASSY. - 3PH/3/4HP/575V(4)	811757-006	
10	MOTOR CAPSCREWS - 3/8-16X3/4	911121-106	
17	O RING - MODULE	961131-036	
18	O RING - REAR BEARING	961131-024	
19	O RING - SHAFT	961131-013	
24	OIL SEAL	116975-000	
21	OIL WICK (BRIDGE)	116949-000	
20	OIL WICK (ROUND)	116948-000	
1	PUMP BODY	804133-011	
9	PUMP BODY CAPS. - 5/16-1/8x3/4	911123-108	
29	SEAL BEARING ASSEMBLY (1) & (4)	816032-000	
16	SHAFT AND BEARING MODULE (3) & (4)	816999-041	

- NOTES:** (1) Seal Bearing Assembly includes Bearing Bracket, Body Gasket, Standard 106076-000 Impeller Nut, Standard 927411-700 Impeller Washer, Module, Impeller Key, "Armité" Seal Assembly, Ceramic Seal Seat, Buna "L" (retainer) Cup, and 5/8 Ounces of Oil.
(2) Includes Face Plate and Buna "N" Oil Seal
(3) Includes Front Sleeve Bearing, Shaft and Sleeve Assembly, two Oil Wicks, three "O" Rings, rear Sleeve Bearing Assembly, four Mounting Screws, Impeller Key, "Armité" Seal Assembly, Ceramic Seal Seat, Buna "L" (retainer) Cup and 5/8 ounces of oil.
(4) The 816706-021 Mechanical Seal on the Universal SBA and the Shaft & Bearing Module must be removed and replaced with a 816706-023 Viton High Temperature Mechanical Seal.
(5) For TEFC or Explosion Proof Motors, please contact the factory.

CIRCULATOR PARTS

MODEL NUMBER S57 - SIZE 5 - Serial No. 6104 & Later HIGH TEMP. ALL BRONZE CONSTRUCTION (225 - 275 DEG. F)			
ITEM NO.	DESCRIPTION	PART NUMBER	ARMSTRONG BAR CODE
28	BODY GASKET	106158-000	
12	BRACKET HOUSING (2)	816966-111	
8	COUPLER ASSEMBLY (Flexible)	806137-000	
0	COUPLER INSERT	875000-800	
22	FACEPLATE	174003-071	
3	FLANGE - 3" NPT - CAST IRON	105188-011	
5	FLANGE BOLTS - 1/2-13x2 1/2	911125-120	
4	FLANGE GASKET	105201-000	
11	FLANGE NUTS - 1/2-13	913125-100	
2	IMPELLER	816304-047	
23	IMPELLER KEY (WOODRUFF #2)	974507-100	
27	IMPELLER NUT	106076-000	
26	IMPELLER WASHER	927311-700	
15	MECHANICAL SEAL ASSY. (Viton) (4)	816706-023	
7	RESILIENT MTD. MOT. ASSY. - 1PH/3/4HP/115/230V	811757-002	
7	RIGID MOUNT. MOT. ASSY. - 1PH/3/4HP/115/230V	831010-062	
7	RIGID MOUNT. MOT. ASSY. - 3PH/3/4HP/208/230/460V(4)	831012-083	
7	RIGID MOUNT. MOT. ASSY. - 3PH/3/4HP/575V(4)	811757-006	
10	MOTOR CAPSCREWS - 3/8-16X3/4	911121-106	
17	O RING - MODULE	961131-036	
18	O RING - REAR BEARING	961131-024	
19	O RING - SHAFT	961131-013	
24	OIL SEAL	116975-000	
21	OIL WICK (BRIDGE)	116949-000	
20	OIL WICK (ROUND)	116948-000	
1	PUMP BODY	804133-041	
9	PUMP BODY CAPS. - 5/16-1/8x3/4	911123-108	
29	SEAL BEARING ASSEMBLY (1) & (4)	816032-000	
16	SHAFT AND BEARING MODULE (3) & (4)	816999-041	

- NOTES:** (1) Seal Bearing Assembly includes Bearing Bracket, Body Gasket, Standard 106076-000 Impeller Nut, Standard 927411-700 Impeller Washer, Module, Impeller Key, "Armité" Seal Assembly, Ceramic Seal Seat, Buna "L" (retainer) Cup, and 5/8 Ounces of Oil.
- (2) Includes Face Plate and Buna "N" Oil Seal
- (3) Includes Front Sleeve Bearing, Shaft and Sleeve Assembly, two Oil Wicks, three "O" Rings, rear Sleeve Bearing Assembly, four Mounting Screws, Impeller Key, "Armité" Seal Assembly, Ceramic Seal Seat, Buna "L" (retainer) Cup and 5/8 ounces of oil.
- (4) The 816706-021 Mechanical Seal on the Universal SBA and the Shaft & Bearing Module must be removed and replaced with a 816706-023 Viton High Temperature Mechanical Seal.
- (5) For TEFC or Explosion Proof Motors, please contact the factory.

CIRCULATOR PARTS

MODEL NUMBER H51 - SIZE 5 - Serial No. 6208 & Later STANDARD AND BRONZE FITTED CONSTRUCTION

ITEM NO.	DESCRIPTION	PART NUMBER	ARMSTRONG BAR CODE
28	BODY GASKET	106158-000	
12	BRACKET HOUSING (2)	816966-111	
8	COUPLER ASSEMBLY (Flexible) 1 PHASE 1/2X1/2	807436-000	
8	COUPLER ASSEMBLY (Flexible) 3 PHASE 1/2X5/8	806137-000	
0	COUPLER INSERT	875000-800	
22	FACEPLATE	174003-071	
3	FLANGE - 1" NPT - CAST IRON	116012-011	
5	FLANGE BOLTS - 7/16-14X1 3/4	911125-120	
4	FLANGE GASKET	105176-000	
11	FLANGE NUTS - 7/16-14 JAM	913125-100	
2	IMPELLER	816302-319	
23	IMPELLER KEY (WOODRUFF #2)	974507-100	
27	IMPELLER NUT	106076-000	
26	IMPELLER WASHER	927311-700	
15	MECHANICAL SEAL ASSEMBLY	816706-021	
7	RESILIENT MTD. MOT. ASSY. - 1PH/1/4HP/115V	816141-001	
7	RIGID MOUNT. MOT. ASSY. - 3PH/1/4HP/208/230/460V(4)	830781-083	
10	MOTOR CAPSCREWS - 3/8-16X3/4	911121-106	
17	O RING - MODULE	961131-036	
18	O RING - REAR BEARING	961131-024	
19	O RING - SHAFT	961131-013	
24	OIL SEAL	116975-000	
21	OIL WICK (BRIDGE)	116949-000	
20	OIL WICK (ROUND)	116948-000	
1	PUMP BODY	816337-011	
9	PUMP BODY CAPS. - 5/16-1/8x3/4	911123-108	
29	SEAL BEARING ASSEMBLY (1)	816032-000	
16	SHAFT AND BEARING MODULE (3)	816999-041	

- NOTES:** (1) Seal Bearing Assembly includes Bearing Bracket, Body Gasket, Standard 106076-000 Impeller Nut, Standard 927411-700 Impeller Washer, Module, Impeller Key, "Armité" Seal Assembly, Ceramic Seal Seat, Buna "L" (retainer) Cup, and 5/8 Ounces of Oil.
- (2) Includes Face Plate and Buna "N" Oil Seal
- (3) Includes Front Sleeve Bearing, Shaft and Sleeve Assembly, two Oil Wicks, three "O" Rings, rear Sleeve Bearing Assembly, four Mounting Screws, Impeller Key, "Armité" Seal Assembly, Ceramic Seal Seat, Buna "L" (retainer) Cup and 5/8 ounces of oil.
- (4) For TEFC or Explosion Proof Motors, please contact the factory.

CIRCULATOR PARTS

MODEL NUMBER H51 - SIZE 5 - Serial No. 6208 & Later ALL BRONZE CONSTRUCTION

ITEM NO.	DESCRIPTION	PART NUMBER	ARMSTRONG BAR CODE
28	BODY GASKET	106158-000	
12	BRACKET HOUSING (2)	816966-111	
8	COUPLER ASSEMBLY (Flexible) 1 PHASE 1/2X1/2	807436-000	
8	COUPLER ASSEMBLY (Flexible) 3 PHASE 1/2X5/8	806137-000	
0	COUPLER INSERT	875000-800	
22	FACEPLATE	174003-071	
3	FLANGE - 1" NPT - BRONZE	116012-041	
5	FLANGE BOLTS - 7/16-14X1 3/4	911125-120	
4	FLANGE GASKET	105176-000	
11	FLANGE NUTS - 7/16-14 JAM	913125-100	
2	IMPELLER	816302-319	
23	IMPELLER KEY (WOODRUFF #2)	974507-100	
27	IMPELLER NUT	106076-000	
26	IMPELLER WASHER	927311-700	
15	MECHANICAL SEAL ASSEMBLY	816706-021	
7	RESILIENT MTD. MOT. ASSY. - 1PH/1/4HP/115V	816141-001	
7	RIGID MOUNT. MOT. ASSY. - 3PH/1/4HP/208/230/460V(4)	830781-083	
10	MOTOR CAPSCREWS - 3/8-16X3/4	911121-106	
17	O RING - MODULE	961131-036	
18	O RING - REAR BEARING	961131-024	
19	O RING - SHAFT	961131-013	
24	OIL SEAL	116975-000	
21	OIL WICK (BRIDGE)	116949-000	
20	OIL WICK (ROUND)	116948-000	
1	PUMP BODY	816337-041	
9	PUMP BODY CAPS. - 5/16-1/8x3/4	911123-108	
29	SEAL BEARING ASSEMBLY (1)	816032-000	
16	SHAFT AND BEARING MODULE (3)	816999-041	

- NOTES:** (1) Seal Bearing Assembly includes Bearing Bracket, Body Gasket, Standard 106076-000 Impeller Nut, Standard 927411-700 Impeller Washer, Module, Impeller Key, "Armité" Seal Assembly, Ceramic Seal Seat, Buna "L" (retainer) Cup, and 5/8 Ounces of Oil.
- (2) Includes Face Plate and Buna "N" Oil Seal
- (3) Includes Front Sleeve Bearing, Shaft and Sleeve Assembly, two Oil Wicks, three "O" Rings, rear Sleeve Bearing Assembly, four Mounting Screws, Impeller Key, "Armité" Seal Assembly, Ceramic Seal Seat, Buna "L" (retainer) Cup and 5/8 ounces of oil.
- (4) For TEFC or Explosion Proof Motors, please contact the factory.

CIRCULATOR PARTS

MODEL NUMBER H51 - SIZE 5 - Serial No. 6208 & Later			
HIGH TEMP. STANDARD CONSTRUCTION (225 - 275 DEG. F)			
ITEM NO.	DESCRIPTION	PART NUMBER	ARMSTRONG BAR CODE
28	BODY GASKET	106158-000	
12	BRACKET HOUSING (2)	816966-111	
8	COUPLER ASSEMBLY (Flexible) 1 PHASE 1/2X1/2	807436-000	
8	COUPLER ASSEMBLY (Flexible) 3 PHASE 1/2X5/8	806137-000	
0	COUPLER INSERT	875000-800	
22	FACEPLATE	174003-071	
3	FLANGE - 1" NPT - CAST IRON	116012-041	
5	FLANGE BOLTS - 7/16-14X1 3/4	911125-120	
4	FLANGE GASKET	105176-000	
11	FLANGE NUTS - 7/16-14 JAM	913125-100	
2	IMPELLER (STEEL)	816302-019	
23	IMPELLER KEY (WOODRUFF #2)	974507-100	
27	IMPELLER NUT	106076-000	
26	IMPELLER WASHER	927311-700	
15	MECHANICAL SEAL ASSY. (Viton) (4)	816706-023	
7	RESILIENT MTD. MOT. ASSY. - 1PH/1/4HP/115V	816141-001	
7	RIGID MOUNT. MOT. ASSY. - 3PH/1/4HP/208/230/460V(5)	830781-083	
10	MOTOR CAPSCREWS - 3/8-16X3/4	911121-106	
17	O RING - MODULE	961131-036	
18	O RING - REAR BEARING	961131-024	
19	O RING - SHAFT	961131-013	
24	OIL SEAL	116975-000	
21	OIL WICK (BRIDGE)	116949-000	
20	OIL WICK (ROUND)	116948-000	
1	PUMP BODY	816337-011	
9	PUMP BODY CAPS. - 5/16-1/8x3/4	911123-108	
29	SEAL BEARING ASSEMBLY (1) & (4)	816032-000	
16	SHAFT AND BEARING MODULE (3) & (4)	816999-041	

- NOTES:** (1) Seal Bearing Assembly includes Bearing Bracket, Body Gasket, Standard 106076-000 Impeller Nut, Standard 927411-700 Impeller Washer, Module, Impeller Key, "Armité" Seal Assembly, Ceramic Seal Seat, Buna "L" (retainer) Cup, and 5/8 Ounces of Oil.
- (2) Includes Face Plate and Buna "N" Oil Seal
- (3) Includes Front Sleeve Bearing, Shaft and Sleeve Assembly, two Oil Wicks, three "O" Rings, rear Sleeve Bearing Assembly, four Mounting Screws, Impeller Key, "Armité" Seal Assembly, Ceramic Seal Seat, Buna "L" (retainer) Cup and 5/8 ounces of oil.
- (4) **The 816706-021 Mechanical Seal on the Universal SBA and the Shaft & Bearing Module must be removed and replaced with a 816706-023 Viton High Temperature Mechanical Seal.**
- (5) **For TEFC or Explosion Proof Motors, please contact the factory.**

CIRCULATOR PARTS

MODEL NUMBER H51 - SIZE 5 - Serial No. 6208 & Later			
HIGH TEMP. BRONZE FITTED CONSTRUCTION (225 - 275 DEG. F)			
ITEM NO.	DESCRIPTION	PART NUMBER	ARMSTRONG BAR CODE
28	BODY GASKET	106158-000	
12	BRACKET HOUSING (2)	816966-111	
8	COUPLER ASSEMBLY (Flexible) 1 PHASE 1/2X1/2	807436-000	
8	COUPLER ASSEMBLY (Flexible) 3 PHASE 1/2X5/8	806137-000	
0	COUPLER INSERT	875000-800	
22	FACEPLATE	174003-071	
3	FLANGE - 1" NPT - CAST IRON	116012-041	
5	FLANGE BOLTS - 7/16-14X1 3/4	911125-120	
4	FLANGE GASKET	105176-000	
11	FLANGE NUTS - 7/16-14 JAM	913125-100	
2	IMPELLER	816302-049	
23	IMPELLER KEY (WOODRUFF #2)	974507-100	
27	IMPELLER NUT	106076-000	
26	IMPELLER WASHER	927311-700	
15	MECHANICAL SEAL ASSY. (Viton) (4)	816706-023	
7	RESILIENT MTD. MOT. ASSY. - 1PH/1/4HP/115V	816141-001	
7	RIGID MOUNT. MOT. ASSY. - 3PH/1/4HP/208/230/460V(5)	830781-083	
10	MOTOR CAPSCREWS - 3/8-16X3/4	911121-106	
17	O RING - MODULE	961131-036	
18	O RING - REAR BEARING	961131-024	
19	O RING - SHAFT	961131-013	
24	OIL SEAL	116975-000	
21	OIL WICK (BRIDGE)	116949-000	
20	OIL WICK (ROUND)	116948-000	
1	PUMP BODY	816337-011	
9	PUMP BODY CAPS. - 5/16-1/8x3/4	911123-108	
29	SEAL BEARING ASSEMBLY (1) & (4)	816032-000	
16	SHAFT AND BEARING MODULE (3) & (4)	816999-041	

- NOTES:** (1) Seal Bearing Assembly includes Bearing Bracket, Body Gasket, Standard 106076-000 Impeller Nut, Standard 927411-700 Impeller Washer, Module, Impeller Key, "Armitte" Seal Assembly, Ceramic Seal Seat, Buna "L" (retainer) Cup, and 5/8 Ounces of Oil.
- (2) Includes Face Plate and Buna "N" Oil Seal
- (3) Includes Front Sleeve Bearing, Shaft and Sleeve Assembly, two Oil Wicks, three "O" Rings, rear Sleeve Bearing Assembly, four Mounting Screws, Impeller Key, "Armitte" Seal Assembly, Ceramic Seal Seat, Buna "L" (retainer) Cup and 5/8 ounces of oil.
- (4) **The 816706-021 Mechanical Seal on the Universal SBA and the Shaft & Bearing Module must be removed and replaced with a 816706-023 Viton High Temperature Mechanical Seal.**
- (5) **For TEFC or Explosion Proof Motors, please contact the factory.**

CIRCULATOR PARTS

MODEL NUMBER H51 - SIZE 5 - Serial No. 6208 & Later			
HIGH TEMP. ALL BRONZE CONSTRUCTION (225 - 275 DEG. F)			
ITEM NO.	DESCRIPTION	PART NUMBER	ARMSTRONG BAR CODE
28	BODY GASKET	106158-000	
12	BRACKET HOUSING (2)	816966-111	
8	COUPLER ASSEMBLY (Flexible) 1 PHASE 1/2X1/2	807436-000	
8	COUPLER ASSEMBLY (Flexible) 3 PHASE 1/2X5/8	806137-000	
0	COUPLER INSERT	875000-800	
22	FACEPLATE	174003-071	
3	FLANGE - 1" NPT - CAST IRON	116012-041	
5	FLANGE BOLTS - 7/16-14X1 3/4	911125-120	
4	FLANGE GASKET	105176-000	
11	FLANGE NUTS - 7/16-14 JAM	913125-100	
2	IMPELLER	816302-049	
23	IMPELLER KEY (WOODRUFF #2)	974507-100	
27	IMPELLER NUT	106076-000	
26	IMPELLER WASHER	927311-700	
15	MECHANICAL SEAL ASSY. (Viton) (4)	816706-023	
7	RESILIENT MTD. MOT. ASSY. - 1PH/1/4HP/115V	816141-001	
7	RIGID MOUNT. MOT. ASSY. - 3PH/1/4HP/208/230/460V(5)	830781-083	
10	MOTOR CAPSCREWS - 3/8-16X3/4	911121-106	
17	O RING - MODULE	961131-036	
18	O RING - REAR BEARING	961131-024	
19	O RING - SHAFT	961131-013	
24	OIL SEAL	116975-000	
21	OIL WICK (BRIDGE)	116949-000	
20	OIL WICK (ROUND)	116948-000	
1	PUMP BODY	816337-041	
9	PUMP BODY CAPS. - 5/16-1/8x3/4	911123-108	
29	SEAL BEARING ASSEMBLY (1) & (4)	816032-000	
16	SHAFT AND BEARING MODULE (3) & (4)	816999-041	

- NOTES:** (1) Seal Bearing Assembly includes Bearing Bracket, Body Gasket, Standard 106076-000 Impeller Nut, Ceramic Seal Seat, Buna "L" (retainer) Cup, and 5/8 Ounces of Oil.
 (2) Includes Face Plate and Buna "N" Oil Seal
 (3) Includes Front Sleeve Bearing, Shaft and Sleeve Assembly, two Oil Wicks, three "O" Rings, rear Sleeve Bearing Assembly, four Mounting Screws, Impeller Key, "Armitite" Seal Assembly, Ceramic Seal Seat, Buna "L" (retainer) Cup and 5/8 ounces of oil.
 (4) The 816706-021 Mechanical Seal on the Universal SBA and the Shaft & Bearing Module must be removed and replaced with a 816706-023 Viton High Temperature Mechanical Seal.
 (5) For TEFC or Explosion Proof Motors, please contact the factory.

CIRCULATOR PARTS

MODEL NUMBER H52 - SIZE 5 - Serial No. 6208 & Later			
STANDARD AND BRONZE FITTED CONSTRUCTION			
ITEM NO.	DESCRIPTION	PART NUMBER	ARMSTRONG BAR CODE
28	BODY GASKET	106158-000	
12	BRACKET HOUSING (2)	816966-111	
8	COUPLER ASSEMBLY (Flexible) 1 PHASE 1/2X1/2	807436-000	
8	COUPLER ASSEMBLY (Flexible) 3 PHASE 1/2X5/8	806137-000	
0	COUPLER INSERT	875000-800	
22	FACEPLATE	174003-071	
3	FLANGE - 1" NPT - CAST IRON	116011-011	
5	FLANGE BOLTS - 7/16-14X1 3/4	911125-120	
4	FLANGE GASKET	105176-000	
11	FLANGE NUTS - 7/16-14 JAM	913125-100	
2	IMPELLER	816302-317	
23	IMPELLER KEY (WOODRUFF #2)	974507-100	
27	IMPELLER NUT	106076-000	
26	IMPELLER WASHER	927311-700	
15	MECHANICAL SEAL ASSEMBLY	816706-021	
7	RESILIENT MTD. MOT. ASSY. - 1PH/1/3HP/115V	816141-002	
7	RIGID MOUNT. MOT. ASSY. - 3PH/1/3HP/208/230/460V(4)	830590-083	
10	MOTOR CAPSCREWS - 3/8-16X3/4	911121-106	
17	O RING - MODULE	961131-036	
18	O RING - REAR BEARING	961131-024	
19	O RING - SHAFT	961131-013	
24	OIL SEAL	116975-000	
21	OIL WICK (BRIDGE)	116949-000	
20	OIL WICK (ROUND)	116948-000	
1	PUMP BODY	816337-011	
9	PUMP BODY CAPS. - 5/16-1/8x3/4	911123-108	
29	SEAL BEARING ASSEMBLY (1)	816032-000	
16	SHAFT AND BEARING MODULE (3)	816999-041	

- NOTES:** (1) Seal Bearing Assembly includes Bearing Bracket, Body Gasket, Standard 106076-000 Impeller Nut, Standard 927411-700 Impeller Washer, Module, Impeller Key, "Armité" Seal Assembly, Ceramic Seal Seat, Buna "L" (retainer) Cup, and 5/8 Ounces of Oil.
- (2) Includes Face Plate and Buna "N" Oil Seal
- (3) Includes Front Sleeve Bearing, Shaft and Sleeve Assembly, two Oil Wicks, three "O" Rings, rear Sleeve Bearing Assembly, four Mounting Screws, Impeller Key, "Armité" Seal Assembly, Ceramic Seal Seat, Buna "L" (retainer) Cup and 5/8 ounces of oil.
- (4) For TEFC or Explosion Proof Motors, please contact the factory.

CIRCULATOR PARTS

MODEL NUMBER H52 - SIZE 5 - Serial No. 6208 & Later ALL BRONZE CONSTRUCTION

ITEM NO.	DESCRIPTION	PART NUMBER	ARMSTRONG BAR CODE
28	BODY GASKET	106158-000	
12	BRACKET HOUSING (2)	816966-111	
8	COUPLER ASSEMBLY (Flexible) 1 PHASE 1/2X1/2	807436-000	
8	COUPLER ASSEMBLY (Flexible) 3 PHASE 1/2X5/8	806137-000	
0	COUPLER INSERT	875000-800	
22	FACEPLATE	174003-071	
3	FLANGE - 1" NPT - BRONZE	116011-041	
5	FLANGE BOLTS - 7/16-14X1 3/4	911125-120	
4	FLANGE GASKET	105176-000	
11	FLANGE NUTS - 7/16-14 JAM	913125-100	
2	IMPELLER	816302-317	
23	IMPELLER KEY (WOODRUFF #2)	974507-100	
27	IMPELLER NUT	106076-000	
26	IMPELLER WASHER	927311-700	
15	MECHANICAL SEAL ASSEMBLY	816706-021	
7	RESILIENT MTD. MOT. ASSY. - 1PH/1/3HP/115V	816141-002	
7	RIGID MOUNT. MOT. ASSY. - 3PH/1/3HP/208/230/460V(4)	830590-083	
10	MOTOR CAPSCREWS - 3/8-16X3/4	911121-106	
17	O RING - MODULE	961131-036	
18	O RING - REAR BEARING	961131-024	
19	O RING - SHAFT	961131-013	
24	OIL SEAL	116975-000	
21	OIL WICK (BRIDGE)	116949-000	
20	OIL WICK (ROUND)	116948-000	
1	PUMP BODY	816337-041	
9	PUMP BODY CAPS. - 5/16-1/8x3/4	911123-108	
29	SEAL BEARING ASSEMBLY (1)	816032-000	
16	SHAFT AND BEARING MODULE (3)	816999-041	

- NOTES:** (1) Seal Bearing Assembly includes Bearing Bracket, Body Gasket, Standard 106076-000 Impeller Nut, Standard 927411-700 Impeller Washer, Module, Impeller Key, "Armité" Seal Assembly, Ceramic Seal Seat, Buna "L" (retainer) Cup, and 5/8 Ounces of Oil.
- (2) Includes Face Plate and Buna "N" Oil Seal
- (3) Includes Front Sleeve Bearing, Shaft and Sleeve Assembly, two Oil Wicks, three "O" Rings, rear Sleeve Bearing Assembly, four Mounting Screws, Impeller Key, "Armité" Seal Assembly, Ceramic Seal Seat, Buna "L" (retainer) Cup and 5/8 ounces of oil.
- (4) For TEFC or Explosion Proof Motors, please contact the factory.

CIRCULATOR PARTS

MODEL NUMBER H52 - SIZE 5 - Serial No. 6208 & Later			
HIGH TEMP. STANDARD CONSTRUCTION (225 - 275 DEG. F)			
ITEM NO.	DESCRIPTION	PART NUMBER	ARMSTRONG BAR CODE
28	BODY GASKET	106158-000	
12	BRACKET HOUSING (2)	816966-111	
8	COUPLER ASSEMBLY (Flexible) 1 PHASE 1/2X1/2	807436-000	
8	COUPLER ASSEMBLY (Flexible) 3 PHASE 1/2X5/8	806137-000	
0	COUPLER INSERT	875000-800	
22	FACEPLATE	174003-071	
3	FLANGE - 1" NPT - CAST IRON	116012-041	
5	FLANGE BOLTS - 7/16-14X1 3/4	911125-120	
4	FLANGE GASKET	105176-000	
11	FLANGE NUTS - 7/16-14 JAM	913125-100	
2	IMPELLER (STEEL)	816302-017	
23	IMPELLER KEY (WOODRUFF #2)	974507-100	
27	IMPELLER NUT	106076-000	
26	IMPELLER WASHER	927311-700	
15	MECHANICAL SEAL ASSY. (Viton) (4)	816706-023	
7	RESILIENT MTD. MOT. ASSY. - 1PH/1/3HP/115V	816141-002	
7	RIGID MOUNT. MOT. ASSY. - 3PH/1/3HP/208/230/460V(5)	830590-083	
10	MOTOR CAPSCREWS - 3/8-16X3/4	911121-106	
17	O RING - MODULE	961131-036	
18	O RING - REAR BEARING	961131-024	
19	O RING - SHAFT	961131-013	
24	OIL SEAL	116975-000	
21	OIL WICK (BRIDGE)	116949-000	
20	OIL WICK (ROUND)	116948-000	
1	PUMP BODY	816337-011	
9	PUMP BODY CAPS. - 5/16-1/8x3/4	911123-108	
29	SEAL BEARING ASSEMBLY (1) & (4)	816032-000	
16	SHAFT AND BEARING MODULE (3) & (4)	816999-041	

- NOTES:** (1) Seal Bearing Assembly includes Bearing Bracket, Body Gasket, Standard 106076-000 Impeller Nut, Standard 927411-700 Impeller Washer, Module, Impeller Key, "Armité" Seal Assembly, Ceramic Seal Seat, Buna "L" (retainer) Cup, and 5/8 Ounces of Oil.
- (2) Includes Face Plate and Buna "N" Oil Seal
- (3) Includes Front Sleeve Bearing, Shaft and Sleeve Assembly, two Oil Wicks, three "O" Rings, rear Sleeve Bearing Assembly, four Mounting Screws, Impeller Key, "Armité" Seal Assembly, Ceramic Seal Seat, Buna "L" (retainer) Cup and 5/8 ounces of oil.
- (4) **The 816706-021 Mechanical Seal on the Universal SBA and the Shaft & Bearing Module must be removed and replaced with a 816706-023 Viton High Temperature Mechanical Seal.**
- (5) **For TEFC or Explosion Proof Motors, please contact the factory.**

CIRCULATOR PARTS

MODEL NUMBER H52 - SIZE 5 - Serial No. 6208 & Later HIGH TEMP. BRONZE FITTED CONSTRUCTION (225 - 275 DEG. F)			
ITEM NO.	DESCRIPTION	PART NUMBER	ARMSTRONG BAR CODE
28	BODY GASKET	106158-000	
12	BRACKET HOUSING (2)	816966-111	
8	COUPLER ASSEMBLY (Flexible) 1 PHASE 1/2X1/2	807436-000	
8	COUPLER ASSEMBLY (Flexible) 3 PHASE 1/2X5/8	806137-000	
0	COUPLER INSERT	875000-800	
22	FACEPLATE	174003-071	
3	FLANGE - 1" NPT - CAST IRON	116011-011	
5	FLANGE BOLTS - 7/16-14X1 3/4	911125-120	
4	FLANGE GASKET	105176-000	
11	FLANGE NUTS - 7/16-14 JAM	913125-100	
2	IMPELLER	816302-047	
23	IMPELLER KEY (WOODRUFF #2)	974507-100	
27	IMPELLER NUT	106076-000	
26	IMPELLER WASHER	927311-700	
15	MECHANICAL SEAL ASSY. (Viton) (4)	816706-023	
7	RESILIENT MTD. MOT. ASSY. - 1PH/1/3HP/115V	816141-002	
7	RIGID MOUNT. MOT. ASSY. - 3PH/1/3HP/208/230/460V(5)	830590-083	
10	MOTOR CAPSCREWS - 3/8-16X3/4	911121-106	
17	O RING - MODULE	961131-036	
18	O RING - REAR BEARING	961131-024	
19	O RING - SHAFT	961131-013	
24	OIL SEAL	116975-000	
21	OIL WICK (BRIDGE)	116949-000	
20	OIL WICK (ROUND)	116948-000	
1	PUMP BODY	816337-011	
9	PUMP BODY CAPS. - 5/16-1/8x3/4	911123-108	
29	SEAL BEARING ASSEMBLY (1) & (4)	816032-000	
16	SHAFT AND BEARING MODULE (3) & (4)	816999-041	

- NOTES:** (1) Seal Bearing Assembly includes Bearing Bracket, Body Gasket, Standard 106076-000 Impeller Nut, Standard 927411-700 Impeller Washer, Module, Impeller Key, "Armite" Seal Assembly, Ceramic Seal Seat, Buna "L" (retainer) Cup, and 5/8 Ounces of Oil.
- (2) Includes Face Plate and Buna "N" Oil Seal
- (3) Includes Front Sleeve Bearing, Shaft and Sleeve Assembly, two Oil Wicks, three "O" Rings, rear Sleeve Bearing Assembly, four Mounting Screws, Impeller Key, "Armite" Seal Assembly, Ceramic Seal Seat, Buna "L" (retainer) Cup and 5/8 ounces of oil.
- (4) The 816706-021 Mechanical Seal on the Universal SBA and the Shaft & Bearing Module must be removed and replaced with a 816706-023 Viton High Temperature Mechanical Seal.
- (5) For TEFC or Explosion Proof Motors, please contact the factory.

CIRCULATOR PARTS

MODEL NUMBER H52 - SIZE 5 - Serial No. 6208 & Later			
HIGH TEMP. ALL BRONZE CONSTRUCTION (225 - 275 DEG. F)			
ITEM NO.	DESCRIPTION	PART NUMBER	ARMSTRONG BAR CODE
28	BODY GASKET	106158-000	
12	BRACKET HOUSING (2)	816966-111	
8	COUPLER ASSEMBLY (Flexible) 1 PHASE 1/2X1/2	807436-000	
8	COUPLER ASSEMBLY (Flexible) 3 PHASE 1/2X5/8	806137-000	
0	COUPLER INSERT	875000-800	
22	FACEPLATE	174003-071	
3	FLANGE - 1" NPT - CAST IRON	116011-041	
5	FLANGE BOLTS - 7/16-14X1 3/4	911125-120	
4	FLANGE GASKET	105176-000	
11	FLANGE NUTS - 7/16-14 JAM	913125-100	
2	IMPELLER	816302-047	
23	IMPELLER KEY (WOODRUFF #2)	974507-100	
27	IMPELLER NUT	106076-000	
26	IMPELLER WASHER	927311-700	
15	MECHANICAL SEAL ASSY. (Viton) (4)	816706-023	
7	RESILIENT MTD. MOT. ASSY. - 1PH/1/3HP/115V	816141-002	
7	RIGID MOUNT. MOT. ASSY. - 3PH/1/3HP/208/230/460V(5)	830590-083	
10	MOTOR CAPSCREWS - 3/8-16X3/4	911121-106	
17	O RING - MODULE	961131-036	
18	O RING - REAR BEARING	961131-024	
19	O RING - SHAFT	961131-013	
24	OIL SEAL	116975-000	
21	OIL WICK (BRIDGE)	116949-000	
20	OIL WICK (ROUND)	116948-000	
1	PUMP BODY	816337-041	
9	PUMP BODY CAPS. - 5/16-1/8x3/4	911123-108	
29	SEAL BEARING ASSEMBLY (1) & (4)	816032-000	
16	SHAFT AND BEARING MODULE (3) & (4)	816999-041	

- NOTES:** (1) Seal Bearing Assembly includes Bearing Bracket, Body Gasket, Standard 106076-000 Impeller Nut, Standard 927411-700 Impeller Washer, Module, Impeller Key, "Armité" Seal Assembly, Ceramic Seal Seat, Buna "L" (retainer) Cup, and 5/8 Ounces of Oil.
- (2) Includes Face Plate and Buna "N" Oil Seal
- (3) Includes Front Sleeve Bearing, Shaft and Sleeve Assembly, two Oil Wicks, three "O" Rings, rear Sleeve Bearing Assembly, four Mounting Screws, Impeller Key, "Armité" Seal Assembly, Ceramic Seal Seat, Buna "L" (retainer) Cup and 5/8 ounces of oil.
- (4) The 816706-021 Mechanical Seal on the Universal SBA and the Shaft & Bearing Module must be removed and replaced with a 816706-023 Viton High Temperature Mechanical Seal.
- (5) For TEFC or Explosion Proof Motors, please contact the factory.

CIRCULATOR PARTS

MODEL NUMBER H53 - SIZE 5 - Serial No. 6208 & Later			
STANDARD AND BRONZE FITTED CONSTRUCTION			
ITEM NO.	DESCRIPTION	PART NUMBER	ARMSTRONG BAR CODE
28	BODY GASKET	106158-000	
12	BRACKET HOUSING (2)	816966-111	
8	COUPLER ASSEMBLY (Flexible) 1/2X5/8	806137-000	
0	COUPLER INSERT	875000-800	
22	FACEPLATE	174003-071	
3	FLANGE - 1 1/2" NPT - CAST IRON	116009-011	
5	FLANGE BOLTS - 7/16-14X1 3/4	911125-120	
4	FLANGE GASKET	105176-000	
11	FLANGE NUTS - 7/16-14 JAM	913125-100	
2	IMPELLER	816303-317	
23	IMPELLER KEY (WOODRUFF #2)	974507-100	
27	IMPELLER NUT	106076-000	
26	IMPELLER WASHER	927311-700	
15	MECHANICAL SEAL ASSEMBLY	816706-021	
7	RIGID MOUNT. MOT. ASSY. - 1PH/1/2HP/115/230V	831009-062	
7	RIGID MOUNT. MOT. ASSY. - 3PH/1/2HP/208/230/460V (4)	831011-083	
7	RIGID MOUNT. MOT. ASSY. - 3PH/1/2HP/575V (4)	811757-004	
10	MOTOR CAPSCREWS - 3/8-16X3/4	911121-106	
17	O RING - MODULE	961131-036	
18	O RING - REAR BEARING	961131-024	
19	O RING - SHAFT	961131-013	
24	OIL SEAL	116975-000	
21	OIL WICK (BRIDGE)	116949-000	
20	OIL WICK (ROUND)	116948-000	
1	PUMP BODY	816337-011	
9	PUMP BODY CAPS. - 5/16-1/8x3/4	911123-108	
29	SEAL BEARING ASSEMBLY (1)	816032-000	
16	SHAFT AND BEARING MODULE (3)	816999-041	

- NOTES:** (1) Seal Bearing Assembly includes Bearing Bracket, Body Gasket, Standard 106076-000 Impeller Nut, Standard 927411-700 Impeller Washer, Module, Impeller Key, "Armité" Seal Assembly, Ceramic Seal Seat, Buna "L" (retainer) Cup, and 5/8 Ounces of Oil.
- (2) Includes Face Plate and Buna "N" Oil Seal
- (3) Includes Front Sleeve Bearing, Shaft and Sleeve Assembly, two Oil Wicks, three "O" Rings, rear Sleeve Bearing Assembly, four Mounting Screws, Impeller Key, "Armité" Seal Assembly, Ceramic Seal Seat, Buna "L" (retainer) Cup and 5/8 ounces of oil.
- (4) For TEFC or Explosion Proof Motors, please contact the factory.

CIRCULATOR PARTS

MODEL NUMBER H53 - SIZE 5 - Serial No. 6208 & Later ALL BRONZE CONSTRUCTION

ITEM NO.	DESCRIPTION	PART NUMBER	ARMSTRONG BAR CODE
28	BODY GASKET	106158-000	
12	BRACKET HOUSING (2)	816966-111	
8	COUPLER ASSEMBLY (Flexible) 1/2X5/8	806137-000	
0	COUPLER INSERT	875000-800	
22	FACEPLATE	174003-071	
3	FLANGE - 1 1/2" NPT - BRONZE	116009-041	
5	FLANGE BOLTS - 7/16-14X1 3/4	911125-120	
4	FLANGE GASKET	105176-000	
11	FLANGE NUTS - 7/16-14 JAM	913125-100	
2	IMPELLER	816303-317	
23	IMPELLER KEY (WOODRUFF #2)	974507-100	
27	IMPELLER NUT	106076-000	
26	IMPELLER WASHER	927311-700	
15	MECHANICAL SEAL ASSEMBLY	816706-021	
7	RIGID MOUNT. MOT. ASSY. - 1PH/1/2HP/115/230V	831009-062	
7	RIGID MOUNT. MOT. ASSY. - 3PH/1/2HP/208/230/460V (4)	831011-083	
7	RIGID MOUNT. MOT. ASSY. - 3PH/1/2HP/575V (4)	811757-004	
10	MOTOR CAPSCREWS - 3/8-16X3/4	911121-106	
17	O RING - MODULE	961131-036	
18	O RING - REAR BEARING	961131-024	
19	O RING - SHAFT	961131-013	
24	OIL SEAL	116975-000	
21	OIL WICK (BRIDGE)	116949-000	
20	OIL WICK (ROUND)	116948-000	
1	PUMP BODY	816337-041	
9	PUMP BODY CAPS. - 5/16-1/8x3/4	911123-108	
29	SEAL BEARING ASSEMBLY (1)	816032-000	
16	SHAFT AND BEARING MODULE (3)	816999-041	

- NOTES:** (1) Seal Bearing Assembly includes Bearing Bracket, Body Gasket, Standard 106076-000 Impeller Nut, Standard 927411-700 Impeller Washer, Module, Impeller Key, "Armité" Seal Assembly, Ceramic Seal Seat, Buna "L" (retainer) Cup, and 5/8 Ounces of Oil.
- (2) Includes Face Plate and Buna "N" Oil Seal
- (3) Includes Front Sleeve Bearing, Shaft and Sleeve Assembly, two Oil Wicks, three "O" Rings, rear Sleeve Bearing Assembly, four Mounting Screws, Impeller Key, "Armité" Seal Assembly, Ceramic Seal Seat, Buna "L" (retainer) Cup and 5/8 ounces of oil.
- (4) For TEFC or Explosion Proof Motors, please contact the factory.

CIRCULATOR PARTS

MODEL NUMBER H53 - SIZE 5 - Serial No. 6208 & Later			
HIGH TEMP. STANDARD CONSTRUCTION (225 - 275 DEG. F)			
ITEM NO.	DESCRIPTION	PART NUMBER	ARMSTRONG BAR CODE
28	BODY GASKET	106158-000	
12	BRACKET HOUSING (2)	816966-111	
8	COUPLER ASSEMBLY (Flexible) 1/2X5/8	806137-000	
0	COUPLER INSERT	875000-800	
22	FACEPLATE	174003-071	
3	FLANGE - 1 1/2" NPT - CAST IRON	116009-041	
5	FLANGE BOLTS - 7/16-14X1 3/4	911125-120	
4	FLANGE GASKET	105176-000	
11	FLANGE NUTS - 7/16-14 JAM	913125-100	
2	IMPELLER (STEEL)	816303-017	
23	IMPELLER KEY (WOODRUFF #2)	974507-100	
27	IMPELLER NUT	106076-000	
26	IMPELLER WASHER	927311-700	
15	MECHANICAL SEAL ASSY. (Viton) (4)	816706-023	
7	RIGID MOUNT. MOT. ASSY. - 1PH/1/2HP/115/230V	831009-062	
7	RIGID MOUNT. MOT. ASSY. - 3PH/1/2HP/208/230/460V(5)	831011-083	
7	RIGID MOUNT. MOT. ASSY. - 3PH/1/2HP/575V(5)	811757-004	
10	MOTOR CAPSCREWS - 3/8-16X3/4	911121-106	
17	O RING - MODULE	961131-036	
18	O RING - REAR BEARING	961131-024	
19	O RING - SHAFT	961131-013	
24	OIL SEAL	116975-000	
21	OIL WICK (BRIDGE)	116949-000	
20	OIL WICK (ROUND)	116948-000	
1	PUMP BODY	816337-011	
9	PUMP BODY CAPS. - 5/16-1/8x3/4	911123-108	
29	SEAL BEARING ASSEMBLY (1) & (4)	816032-000	
16	SHAFT AND BEARING MODULE (3) & (4)	816999-041	

- NOTES:** (1) Seal Bearing Assembly includes Bearing Bracket, Body Gasket, Standard 106076-000 Impeller Nut, Standard 927411-700 Impeller Washer, Module, Impeller Key, "Armité" Seal Assembly, Ceramic Seal Seat, Buna "L" (retainer) Cup, and 5/8 Ounces of Oil.
- (2) Includes Face Plate and Buna "N" Oil Seal
- (3) Includes Front Sleeve Bearing, Shaft and Sleeve Assembly, two Oil Wicks, three "O" Rings, rear Sleeve Bearing Assembly, four Mounting Screws, Impeller Key, "Armité" Seal Assembly, Ceramic Seal Seat, Buna "L" (retainer) Cup and 5/8 ounces of oil.
- (4) **The 816706-021 Mechanical Seal on the Universal SBA and the Shaft & Bearing Module must be removed and replaced with a 816706-023 Viton High Temperature Mechanical Seal.**
- (5) **For TEFC or Explosion Proof Motors, please contact the factory.**

CIRCULATOR PARTS

MODEL NUMBER H53 - SIZE 5 - Serial No. 6208 & Later HIGH TEMP. BRONZE FITTED CONSTRUCTION (225 - 275 DEG. F)			
ITEM NO.	DESCRIPTION	PART NUMBER	ARMSTRONG BAR CODE
28	BODY GASKET	106158-000	
12	BRACKET HOUSING (2)	816966-111	
8	COUPLER ASSEMBLY (Flexible) 1/2X5/8	806137-000	
0	COUPLER INSERT	875000-800	
22	FACEPLATE	174003-071	
3	FLANGE - 1 1/2" NPT - CAST IRON	116009-011	
5	FLANGE BOLTS - 7/16-14X1 3/4	911125-120	
4	FLANGE GASKET	105176-000	
11	FLANGE NUTS - 7/16-14 JAM	913125-100	
2	IMPELLER	816303-047	
23	IMPELLER KEY (WOODRUFF #2)	974507-100	
27	IMPELLER NUT	106076-000	
26	IMPELLER WASHER	927311-700	
15	MECHANICAL SEAL ASSY. (Viton) (4)	816706-023	
7	RIGID MOUNT. MOT. ASSY. - 1PH/1/2HP/115/230V	831009-062	
7	RIGID MOUNT. MOT. ASSY. - 3PH/1/2HP/208/230/460V(5)	831011-083	
7	RIGID MOUNT. MOT. ASSY. - 3PH/1/2HP/575V(5)	811757-004	
10	MOTOR CAPSCREWS - 3/8-16X3/4	911121-106	
17	O RING - MODULE	961131-036	
18	O RING - REAR BEARING	961131-024	
19	O RING - SHAFT	961131-013	
24	OIL SEAL	116975-000	
21	OIL WICK (BRIDGE)	116949-000	
20	OIL WICK (ROUND)	116948-000	
1	PUMP BODY	816337-011	
9	PUMP BODY CAPS. - 5/16-1/8x3/4	911123-108	
29	SEAL BEARING ASSEMBLY (1) & (4)	816032-000	
16	SHAFT AND BEARING MODULE (3) & (4)	816999-041	

- NOTES:** (1) Seal Bearing Assembly includes Bearing Bracket, Body Gasket, Standard 106076-000 Impeller Nut, Standard 927411-700 Impeller Washer, Module, Impeller Key, "Armite" Seal Assembly, Ceramic Seal Seat, Buna "L" (retainer) Cup, and 5/8 Ounces of Oil.
(2) Includes Face Plate and Buna "N" Oil Seal
(3) Includes Front Sleeve Bearing, Shaft and Sleeve Assembly, two Oil Wicks, three "O" Rings, rear Sleeve Bearing Assembly, four Mounting Screws, Impeller Key, "Armite" Seal Assembly, Ceramic Seal Seat, Buna "L" (retainer) Cup and 5/8 ounces of oil.
(4) The 816706-021 Mechanical Seal on the Universal SBA and the Shaft & Bearing Module must be removed and replaced with a 816706-023 Viton High Temperature Mechanical Seal.
(5) For TEFC or Explosion Proof Motors, please contact the factory.

CIRCULATOR PARTS

MODEL NUMBER H53 - SIZE 5 - Serial No. 6208 & Later			
HIGH TEMP. ALL BRONZE CONSTRUCTION (225 - 275 DEG. F)			
ITEM NO.	DESCRIPTION	PART NUMBER	ARMSTRONG BAR CODE
28	BODY GASKET	106158-000	
12	BRACKET HOUSING (2)	816966-111	
8	COUPLER ASSEMBLY (Flexible) 1/2X5/8	806137-000	
0	COUPLER INSERT	875000-800	
22	FACEPLATE	174003-071	
3	FLANGE - 1 1/2" NPT - BRONZE	116009-041	
5	FLANGE BOLTS - 7/16-14X1 3/4	911125-120	
4	FLANGE GASKET	105176-000	
11	FLANGE NUTS - 7/16-14 JAM	913125-100	
2	IMPELLER	816303-047	
23	IMPELLER KEY (WOODRUFF #2)	974507-100	
27	IMPELLER NUT	106076-000	
26	IMPELLER WASHER	927311-700	
15	MECHANICAL SEAL ASSY. (Viton) (4)	816706-023	
7	RIGID MOUNT. MOT. ASSY. - 1PH/1/2HP/115/230V	831009-062	
7	RIGID MOUNT. MOT. ASSY. - 3PH/1/2HP/208/230/460V(5)	831011-083	
7	RIGID MOUNT. MOT. ASSY. - 3PH/1/2HP/575V(5)	811757-004	
10	MOTOR CAPSCREWS - 3/8-16X3/4	911121-106	
17	O RING - MODULE	961131-036	
18	O RING - REAR BEARING	961131-024	
19	O RING - SHAFT	961131-013	
24	OIL SEAL	116975-000	
21	OIL WICK (BRIDGE)	116949-000	
20	OIL WICK (ROUND)	116948-000	
1	PUMP BODY	816337-041	
9	PUMP BODY CAPS. - 5/16-1/8x3/4	911123-108	
29	SEAL BEARING ASSEMBLY (1) & (4)	816032-000	
16	SHAFT AND BEARING MODULE (3) & (4)	816999-041	

- NOTES:** (1) Seal Bearing Assembly includes Bearing Bracket, Body Gasket, Standard 106076-000 Impeller Nut, Standard 927411-700 Impeller Washer, Module, Impeller Key, "Armité" Seal Assembly, Ceramic Seal Seat, Buna "L" (retainer) Cup, and 5/8 Ounces of Oil.
(2) Includes Face Plate and Buna "N" Oil Seal
(3) Includes Front Sleeve Bearing, Shaft and Sleeve Assembly, two Oil Wicks, three "O" Rings, rear Sleeve Bearing Assembly, four Mounting Screws, Impeller Key, "Armité" Seal Assembly, Ceramic Seal Seat, Buna "L" (retainer) Cup and 5/8 ounces of oil.
(4) The 816706-021 Mechanical Seal on the Universal SBA and the Shaft & Bearing Module must be removed and replaced with a 816706-023 Viton High Temperature Mechanical Seal.
(5) For TEFC or Explosion Proof Motors, please contact the factory.

CIRCULATOR PARTS

MODEL NUMBER H54 - SIZE 5 - Serial No. 6208 & Later			
STANDARD AND BRONZE FITTED CONSTRUCTION			
ITEM NO.	DESCRIPTION	PART NUMBER	ARMSTRONG BAR CODE
28	BODY GASKET	106158-000	
12	BRACKET HOUSING (2)	816966-111	
8	COUPLER ASSEMBLY (Flexible) 1/2X5/8	806137-000	
0	COUPLER INSERT	875000-800	
22	FACEPLATE	174003-071	
3	FLANGE - 2" NPT - CAST IRON	106074-011	
5	FLANGE BOLTS - 1/2-13X2 1/4	911125-120	
4	FLANGE GASKET	105176-000	
11	FLANGE NUTS - 7/16-14 JAM	913125-100	
2	IMPELLER	816304-317	
23	IMPELLER KEY (WOODRUFF #2)	974507-100	
27	IMPELLER NUT	106076-000	
26	IMPELLER WASHER	927311-700	
15	MECHANICAL SEAL ASSEMBLY	816706-021	
7	RIGID MOUNT. MOT. ASSY. - 1PH/3/4HP/115/230V	831010-062	
7	RIGID MOUNT. MOT. ASSY. - 3PH/3/4HP/208/230/460V(4)	831012-083	
7	RIGID MOUNT. MOT. ASSY. - 3PH/3/4HP/575V(4)	811757-006	
10	MOTOR CAPSCREWS - 3/8-16X3/4	911121-106	
17	O RING - MODULE	961131-036	
18	O RING - REAR BEARING	961131-024	
19	O RING - SHAFT	961131-013	
24	OIL SEAL	116975-000	
21	OIL WICK (BRIDGE)	116949-000	
20	OIL WICK (ROUND)	116948-000	
1	PUMP BODY	816338-011	
9	PUMP BODY CAPS. - 5/16-1/8x3/4	911123-108	
29	SEAL BEARING ASSEMBLY (1)	816032-000	
16	SHAFT AND BEARING MODULE (3)	816999-041	

- NOTES:** (1) Seal Bearing Assembly includes Bearing Bracket, Body Gasket, Standard 106076-000 Impeller Nut, Standard 927411-700 Impeller Washer, Module, Impeller Key, "Armité" Seal Assembly, Ceramic Seal Seat, Buna "L" (retainer) Cup, and 5/8 Ounces of Oil.
- (2) Includes Face Plate and Buna "N" Oil Seal
- (3) Includes Front Sleeve Bearing, Shaft and Sleeve Assembly, two Oil Wicks, three "O" Rings, rear Sleeve Bearing Assembly, four Mounting Screws, Impeller Key, "Armité" Seal Assembly, Ceramic Seal Seat, Buna "L" (retainer) Cup and 5/8 ounces of oil.
- (4) For TEFC or Explosion Proof Motors, please contact the factory.

CIRCULATOR PARTS

MODEL NUMBER H54 - SIZE 5 - Serial No. 6208 & Later ALL BRONZE CONSTRUCTION

ITEM NO.	DESCRIPTION	PART NUMBER	ARMSTRONG BAR CODE
28	BODY GASKET	106158-000	
12	BRACKET HOUSING (2)	816966-111	
8	COUPLER ASSEMBLY (Flexible) 1/2X5/8	806137-000	
0	COUPLER INSERT	875000-800	
22	FACEPLATE	174003-071	
3	FLANGE - 2" NPT - BRONZE	106074-041	
5	FLANGE BOLTS - 1/2-13X2 1/4	911125-120	
4	FLANGE GASKET	105176-000	
11	FLANGE NUTS - 7/16-14 JAM	913125-100	
2	IMPELLER	816304-317	
23	IMPELLER KEY (WOODRUFF #2)	974507-100	
27	IMPELLER NUT	106076-000	
26	IMPELLER WASHER	927311-700	
15	MECHANICAL SEAL ASSEMBLY	816706-021	
7	RIGID MOUNT. MOT. ASSY. - 1PH/3/4HP/115/230V	831010-062	
7	RIGID MOUNT. MOT. ASSY. - 3PH/3/4HP/208/230/460V(4)	831012-083	
7	RIGID MOUNT. MOT. ASSY. - 3PH/3/4HP/575V(4)	811757-006	
10	MOTOR CAPSCREWS - 3/8-16X3/4	911121-106	
17	O RING - MODULE	961131-036	
18	O RING - REAR BEARING	961131-024	
19	O RING - SHAFT	961131-013	
24	OIL SEAL	116975-000	
21	OIL WICK (BRIDGE)	116949-000	
20	OIL WICK (ROUND)	116948-000	
1	PUMP BODY	816338-041	
9	PUMP BODY CAPS. - 5/16-1/8x3/4	911123-108	
29	SEAL BEARING ASSEMBLY (1)	816032-000	
16	SHAFT AND BEARING MODULE (3)	816999-041	

- NOTES:** (1) Seal Bearing Assembly includes Bearing Bracket, Body Gasket, Standard 106076-000 Impeller Nut, Standard 927411-700 Impeller Washer, Module, Impeller Key, "Armité" Seal Assembly, Ceramic Seal Seat, Buna "L" (retainer) Cup, and 5/8 Ounces of Oil.
(2) Includes Face Plate and Buna "N" Oil Seal
(3) Includes Front Sleeve Bearing, Shaft and Sleeve Assembly, two Oil Wicks, three "O" Rings, rear Sleeve Bearing Assembly, four Mounting Screws, Impeller Key, "Armité" Seal Assembly, Ceramic Seal Seat, Buna "L" (retainer) Cup and 5/8 ounces of oil.
(4) For TEFC or Explosion Proof Motors, please contact the factory.

CIRCULATOR PARTS

MODEL NUMBER H54 - SIZE 5 - Serial No. 6208 & Later			
HIGH TEMP. STANDARD CONSTRUCTION (225 - 275 DEG. F)			
ITEM NO.	DESCRIPTION	PART NUMBER	ARMSTRONG BAR CODE
28	BODY GASKET	106158-000	
12	BRACKET HOUSING (2)	816966-111	
8	COUPLER ASSEMBLY (Flexible) 1/2X5/8	806137-000	
0	COUPLER INSERT	875000-800	
22	FACEPLATE	174003-071	
3	FLANGE - 2" NPT - CAST IRON	106074-011	
5	FLANGE BOLTS - 1/2-13X2 1/4	911125-120	
4	FLANGE GASKET	105176-000	
11	FLANGE NUTS - 7/16-14 JAM	913125-100	
2	IMPELLER	816304-017	
23	IMPELLER KEY (WOODRUFF #2)	974507-100	
27	IMPELLER NUT	106076-000	
26	IMPELLER WASHER	927311-700	
15	MECHANICAL SEAL ASSEMBLY	816706-023	
7	RIGID MOUNT. MOT. ASSY. - 1PH/3/4HP/115/230V	831010-062	
7	RIGID MOUNT. MOT. ASSY. - 3PH/3/4HP/208/230/460V(5)	831012-083	
7	RIGID MOUNT. MOT. ASSY. - 3PH/3/4HP/575V(5)	811757-006	
10	MOTOR CAPSCREWS - 3/8-16X3/4	911121-106	
17	O RING - MODULE	961131-036	
18	O RING - REAR BEARING	961131-024	
19	O RING - SHAFT	961131-013	
24	OIL SEAL	116975-000	
21	OIL WICK (BRIDGE)	116949-000	
20	OIL WICK (ROUND)	116948-000	
1	PUMP BODY	816338-011	
9	PUMP BODY CAPS. - 5/16-1/8x3/4	911123-108	
29	SEAL BEARING ASSEMBLY (1) & (4)	816032-000	
16	SHAFT AND BEARING MODULE (3) & (4)	816999-041	

- NOTES:** (1) Seal Bearing Assembly includes Bearing Bracket, Body Gasket, Standard 106076-000 Impeller Nut, Standard 927411-700 Impeller Washer, Module, Impeller Key, "Armité" Seal Assembly, Ceramic Seal Seat, Buna "L" (retainer) Cup, and 5/8 Ounces of Oil.
- (2) Includes Face Plate and Buna "N" Oil Seal
- (3) Includes Front Sleeve Bearing, Shaft and Sleeve Assembly, two Oil Wicks, three "O" Rings, rear Sleeve Bearing Assembly, four Mounting Screws, Impeller Key, "Armité" Seal Assembly, Ceramic Seal Seat, Buna "L" (retainer) Cup and 5/8 ounces of oil.
- (4) **The 816706-021 Mechanical Seal on the Universal SBA and the Shaft & Bearing Module must be removed and replaced with a 816706-023 Viton High Temperature Mechanical Seal.**
- (5) **For TEFC or Explosion Proof Motors, please contact the factory.**

CIRCULATOR PARTS

MODEL NUMBER H54 - SIZE 5 - Serial No. 6208 & Later HIGH TEMP. BRONZE FITTED CONSTRUCTION (225 - 275 DEG. F)			
ITEM NO.	DESCRIPTION	PART NUMBER	ARMSTRONG BAR CODE
28	BODY GASKET	106158-000	
12	BRACKET HOUSING (2)	816966-111	
8	COUPLER ASSEMBLY (Flexible) 1/2X5/8	806137-000	
0	COUPLER INSERT	875000-800	
22	FACEPLATE	174003-071	
3	FLANGE - 2" NPT - BRONZE	106074-041	
5	FLANGE BOLTS - 1/2-13X2 1/4	911125-120	
4	FLANGE GASKET	105176-000	
11	FLANGE NUTS - 7/16-14 JAM	913125-100	
2	IMPELLER	816304-047	
23	IMPELLER KEY (WOODRUFF #2)	974507-100	
27	IMPELLER NUT	106076-000	
26	IMPELLER WASHER	927311-700	
15	MECHANICAL SEAL ASSEMBLY	816706-023	
7	RIGID MOUNT. MOT. ASSY. - 1PH/3/4HP/115/230V	831010-062	
7	RIGID MOUNT. MOT. ASSY. - 3PH/3/4HP/208/230/460V(5)	831012-083	
7	RIGID MOUNT. MOT. ASSY. - 3PH/3/4HP/575V(5)	811757-006	
10	MOTOR CAPSCREWS - 3/8-16X3/4	911121-106	
17	O RING - MODULE	961131-036	
18	O RING - REAR BEARING	961131-024	
19	O RING - SHAFT	961131-013	
24	OIL SEAL	116975-000	
21	OIL WICK (BRIDGE)	116949-000	
20	OIL WICK (ROUND)	116948-000	
1	PUMP BODY	816338-011	
9	PUMP BODY CAPS. - 5/16-1/8x3/4	911123-108	
29	SEAL BEARING ASSEMBLY (1) & (4)	816032-000	
16	SHAFT AND BEARING MODULE (3) & (4)	816999-041	

- NOTES:** (1) Seal Bearing Assembly includes Bearing Bracket, Body Gasket, Standard 106076-000 Impeller Nut, Standard 927411-700 Impeller Washer, Module, Impeller Key, "Armita" Seal Assembly, Ceramic Seal Seat, Buna "L" (retainer) Cup, and 5/8 Ounces of Oil.
- (2) Includes Face Plate and Buna "N" Oil Seal
- (3) Includes Front Sleeve Bearing, Shaft and Sleeve Assembly, two Oil Wicks, three "O" Rings, rear Sleeve Bearing Assembly, four Mounting Screws, Impeller Key, "Armita" Seal Assembly, Ceramic Seal Seat, Buna "L" (retainer) Cup and 5/8 ounces of oil.
- (4) The 816706-021 Mechanical Seal on the Universal SBA and the Shaft & Bearing Module must be removed and replaced with a 816706-023 Viton High Temperature Mechanical Seal.
- (5) For TEFC or Explosion Proof Motors, please contact the factory.

CIRCULATOR PARTS

MODEL NUMBER H54 - SIZE 5 - Serial No. 6208 & Later HIGH TEMP. ALL BRONZE CONSTRUCTION (225 - 275 DEG. F)			
ITEM NO.	DESCRIPTION	PART NUMBER	ARMSTRONG BAR CODE
28	BODY GASKET	106158-000	
12	BRACKET HOUSING (2)	816966-111	
8	COUPLER ASSEMBLY (Flexible) 1/2X5/8	806137-000	
0	COUPLER INSERT	875000-800	
22	FACEPLATE	174003-071	
3	FLANGE - 2" NPT - BRONZE	106074-041	
5	FLANGE BOLTS - 1/2-13X2 1/4	911125-120	
4	FLANGE GASKET	105176-000	
11	FLANGE NUTS - 7/16-14 JAM	913125-100	
2	IMPELLER	816304-047	
23	IMPELLER KEY (WOODRUFF #2)	974507-100	
27	IMPELLER NUT	106076-000	
26	IMPELLER WASHER	927311-700	
15	MECHANICAL SEAL ASSEMBLY	816706-021	
7	RIGID MOUNT. MOT. ASSY. - 1PH/3/4HP/115/230V	831010-062	
7	RIGID MOUNT. MOT. ASSY. - 3PH/3/4HP/208/230/460V(5)	831012-083	
7	RIGID MOUNT. MOT. ASSY. - 3PH/3/4HP/575V(5)	811757-006	
10	MOTOR CAPSCREWS - 3/8-16X3/4	911121-106	
17	O RING - MODULE	961131-036	
18	O RING - REAR BEARING	961131-024	
19	O RING - SHAFT	961131-013	
24	OIL SEAL	116975-000	
21	OIL WICK (BRIDGE)	116949-000	
20	OIL WICK (ROUND)	116948-000	
1	PUMP BODY	816338-041	
9	PUMP BODY CAPS. - 5/16-1/8x3/4	911123-108	
29	SEAL BEARING ASSEMBLY (1) & (4)	816032-000	
16	SHAFT AND BEARING MODULE (3) & (4)	816999-041	

- NOTES:** (1) Seal Bearing Assembly includes Bearing Bracket, Body Gasket, Standard 106076-000 Impeller Nut, Standard 927411-700 Impeller Washer, Module, Impeller Key, "Armite" Seal Assembly, Ceramic Seal Seat, Buna "L" (retainer) Cup, and 5/8 Ounces of Oil.
- (2) Includes Face Plate and Buna "N" Oil Seal
- (3) Includes Front Sleeve Bearing, Shaft and Sleeve Assembly, two Oil Wicks, three "O" Rings, rear Sleeve Bearing Assembly, four Mounting Screws, Impeller Key, "Armite" Seal Assembly, Ceramic Seal Seat, Buna "L" (retainer) Cup and 5/8 ounces of oil.
- (4) The 816706-021 Mechanical Seal on the Universal SBA and the Shaft & Bearing Module must be removed and replaced with a 816706-023 Viton High Temperature Mechanical Seal.
- (5) For TEFC or Explosion Proof Motors, please contact the factory.

CIRCULATOR PARTS

MODEL NUMBER 1050 1B - SIZE 5 Serial No. 6208 & Later STANDARD AND BRONZE FITTED CONSTRUCTION

ITEM NO.	DESCRIPTION	PART NUMBER	ARMSTRONG BAR CODE
28	BODY GASKET	106158-000	
12	BRACKET HOUSING (2)	816966-111	
8	COUPLER ASSEMBLY (Flexible) 1 PHASE 1/2X1/2	807436-000	
8	COUPLER ASSEMBLY (Flexible) 3 PHASE 1/2X5/8	806137-000	
0	COUPLER INSERT	875000-800	
22	FACEPLATE	174003-071	
3	FLANGE - 1" NPT - CAST IRON	116012-011	
5	FLANGE BOLTS - 7/16-14X1 3/4	911125-120	
4	FLANGE GASKET	105176-000	
11	FLANGE NUTS - 7/16-14 JAM	913125-100	
2	IMPELLER - 5 1/4" DIA. (See note 4)	816302-317	
2	IMPELLER - 4 3/4" DIA. (See note 4)	816302-321	
2	IMPELLER - 4 3/8" DIA. (See note 4)	816302-324	
2	IMPELLER - 4" DIA. (See note 4)	816302-327	
23	IMPELLER KEY (WOODRUFF #2)	974507-100	
27	IMPELLER NUT	106076-000	
26	IMPELLER WASHER	927311-700	
15	MECHANICAL SEAL ASSEMBLY	816706-021	
7	RESILIENT MTD. MOT. ASSY. - 1PH/1/4HP/115V	816141-001	
7	RIGID MOUNT. MOT. ASSY. - 3PH/1/4HP/208/230/460V(5)	830781-083	
7	RESILIENT MTD. MOT. ASSY. - 1PH/1/3HP/115V	816141-002	
7	RIGID MOUNT. MOT. ASSY. - 3PH/1/3HP/208/230/460V(5)	830590-083	
10	MOTOR CAPSCREWS - 3/8-16X3/4	911121-106	
17	O RING - MODULE	961131-036	
18	O RING - REAR BEARING	961131-024	
19	O RING - SHAFT	961131-013	
24	OIL SEAL	116975-000	
21	OIL WICK (BRIDGE)	116949-000	
20	OIL WICK (ROUND)	116948-000	
1	PUMP BODY	816337-011	
9	PUMP BODY CAPS. - 5/16-1/8x3/4	911123-108	
29	SEAL BEARING ASSEMBLY (1)	816032-000	
16	SHAFT AND BEARING MODULE (3)	816999-041	

- NOTES:** (1) Seal Bearing Assembly includes Bearing Bracket, Body Gasket, Standard 106076-000 Impeller Nut, Standard 927411-700 Impeller Washer, Module, Impeller Key, "Armité" Seal Assembly, Ceramic Seal Seat, Buna "L" (retainer) Cup, and 5/8 Ounces of Oil.
- (2) Includes Face Plate and Buna "N" Oil Seal
- (3) Includes Front Sleeve Bearing, Shaft and Sleeve Assembly, two Oil Wicks, three "O" Rings, rear Sleeve Bearing Assembly, four Mounting Screws, Impeller Key, "Armité" Seal Assembly, Ceramic Seal Seat, Buna "L" (retainer) Cup and 5/8 ounces of oil.
- (4) Impeller Part Numbers are for stock diameter Impellers. For Impeller Diameters not listed, please contact the factory.
- (5) For TEFC or Explosion Proof Motors, please contact the factory.

CIRCULATOR PARTS

MODEL NUMBER 1050 1B - SIZE 5 Serial No. 6208 & Later ALL BRONZE CONSTRUCTION

ITEM NO.	DESCRIPTION	PART NUMBER	ARMSTRONG BAR CODE
28	BODY GASKET	106158-000	
12	BRACKET HOUSING (2)	816966-111	
8	COUPLER ASSEMBLY (Flexible) 1 PHASE 1/2X1/2	807436-000	
8	COUPLER ASSEMBLY (Flexible) 3 PHASE 1/2X5/8	806137-000	
0	COUPLER INSERT	875000-800	
22	FACEPLATE	174003-071	
3	FLANGE - 1" NPT - BRONZE	116012-041	
5	FLANGE BOLTS - 7/16-14X1 3/4	911125-120	
4	FLANGE GASKET	105176-000	
11	FLANGE NUTS - 7/16-14 JAM	913125-100	
2	IMPELLER - 5 1/4" DIA. (See note 4)	816302-317	
2	IMPELLER - 4 3/4" DIA. (See note 4)	816302-321	
2	IMPELLER - 4 3/8" DIA. (See note 4)	816302-324	
2	IMPELLER - 4" DIA. (See note 4)	816302-327	
23	IMPELLER KEY (WOODRUFF #2)	974507-100	
27	IMPELLER NUT	106076-000	
26	IMPELLER WASHER	927311-700	
15	MECHANICAL SEAL ASSEMBLY	816706-021	
7	RESILIENT MTD. MOT. ASSY. - 1PH/1/4HP/115V	816141-001	
7	RIGID MOUNT. MOT. ASSY. - 3PH/1/4HP/208/230/460V(5)	830781-083	
7	RESILIENT MTD. MOT. ASSY. - 1PH/1/3HP/115V	816141-002	
7	RIGID MOUNT. MOT. ASSY. - 3PH/1/3HP/208/230/460V(5)	830590-083	
10	MOTOR CAPSCREWS - 3/8-16X3/4	911121-106	
17	O RING - MODULE	961131-036	
18	O RING - REAR BEARING	961131-024	
19	O RING - SHAFT	961131-013	
24	OIL SEAL	116975-000	
21	OIL WICK (BRIDGE)	116949-000	
20	OIL WICK (ROUND)	116948-000	
1	PUMP BODY	816337-041	
9	PUMP BODY CAPS. - 5/16-1/8x3/4	911123-108	
29	SEAL BEARING ASSEMBLY (1)	816032-000	
16	SHAFT AND BEARING MODULE (3)	816999-041	

- NOTES:** (1) Seal Bearing Assembly includes Bearing Bracket, Body Gasket, Standard 106076-000 Impeller Nut, Standard 927411-700 Impeller Washer, Module, Impeller Key, "Armite" Seal Assembly, Ceramic Seal Seat, Buna "L" (retainer) Cup, and 5/8 Ounces of Oil.
- (2) Includes Face Plate and Buna "N" Oil Seal
- (3) Includes Front Sleeve Bearing, Shaft and Sleeve Assembly, two Oil Wicks, three "O" Rings, rear Sleeve Bearing Assembly, four Mounting Screws, Impeller Key, "Armite" Seal Assembly, Ceramic Seal Seat, Buna "L" (retainer) Cup and 5/8 ounces of oil.
- (4) Impeller Part Numbers are for stock diameter Impellers. For Impeller Diameters not listed, please contact the factory.
- (5) For TEFC or Explosion Proof Motors, contact the factory.

CIRCULATOR PARTS

MODEL NUMBER 1050 1B - SIZE 5 Serial No. 6208 & Later HIGH TEMP. STANDARD CONSTRUCTION (225 - 275 DEG. F)

ITEM NO.	DESCRIPTION	PART NUMBER	ARMSTRONG BAR CODE
28	BODY GASKET	106158-000	
12	BRACKET HOUSING (2)	816966-111	
8	COUPLER ASSEMBLY (Flexible) 1 PHASE 1/2X1/2	807436-000	
8	COUPLER ASSEMBLY (Flexible) 3 PHASE 1/2X5/8	806137-000	
0	COUPLER INSERT	875000-800	
22	FACEPLATE	174003-071	
3	FLANGE - 1" NPT - CAST IRON	116012-011	
5	FLANGE BOLTS - 7/16-14X1 3/4	911125-120	
4	FLANGE GASKET	105176-000	
11	FLANGE NUTS - 7/16-14 JAM	913125-100	
2	IMPELLER (Steel) - 5 1/4" DIA. (See note 5)	816302-017	
2	IMPELLER (Steel) - 4 3/4" DIA. (See note 5)	816302-021	
2	IMPELLER (Steel) - 4 3/8" DIA. (See note 5)	816302-024	
2	IMPELLER (Steel) - 4" DIA. (See note 5)	816302-027	
23	IMPELLER KEY (WOODRUFF #2)	974507-100	
27	IMPELLER NUT	106076-000	
26	IMPELLER WASHER	927311-700	
15	MECHANICAL SEAL ASSY. (Viton) (4)	816706-023	
7	RESILIENT MTD. MOT. ASSY. - 1PH/1/4HP/115V	816141-001	
7	RIGID MOUNT. MOT. ASSY. - 3PH/1/4HP/208/230/460V(6)	830781-083	
7	RESILIENT MTD. MOT. ASSY. - 1PH/1/3HP/115V	816141-002	
7	RIGID MOUNT. MOT. ASSY. - 3PH/1/3HP/208/230/460V(6)	830590-083	
10	MOTOR CAPSCREWS - 3/8-16X3/4	911121-106	
17	O RING - MODULE	961131-036	
18	O RING - REAR BEARING	961131-024	
19	O RING - SHAFT	961131-013	
24	OIL SEAL	116975-000	
21	OIL WICK (BRIDGE)	116949-000	
20	OIL WICK (ROUND)	116948-000	
1	PUMP BODY	816337-011	
9	PUMP BODY CAPS. - 5/16-1/8x3/4	911123-108	
29	SEAL BEARING ASSEMBLY (1) & (4)	816032-000	
16	SHAFT AND BEARING MODULE (3) & (4)	816999-041	

- NOTES:** (1) Seal Bearing Assembly includes Bearing Bracket, Body Gasket, Standard 106076-000 Impeller Nut, Standard 927411-700 Impeller Washer, Module, Impeller Key, "Armite" Seal Assembly, Ceramic Seal Seat, Buna "L" (retainer) Cup, and 5/8 Ounces of Oil.
- (2) Includes Face Plate and Buna "N" Oil Seal
- (3) Includes Front Sleeve Bearing, Shaft and Sleeve Assembly, two Oil Wicks, three "O" Rings, rear Sleeve Bearing Assembly, four Mounting Screws, Impeller Key, "Armite" Seal Assembly, Ceramic Seal Seat, Buna "L" (retainer) Cup and 5/8 ounces of oil.
- (4) The 816706-021 Mechanical Seal on the Universal SBA and the Shaft & Bearing Module must be removed and replaced with a 816706-023 Viton High Temperature Mechanical Seal.
- (5) Impeller Part Number is for a full diameter Impeller. Always specify the Pump Serial Number and if possible the diameter of the impeller being replaced.
- (6) For TEFC or Explosion Proof Motors, contact the factory.

CIRCULATOR PARTS

MODEL NUMBER 1050 1B - SIZE 5 Serial No. 6208 & Later HIGH TEMP. BRONZE FITTED CONSTRUCTION (225 - 275 DEG. F)			
ITEM NO.	DESCRIPTION	PART NUMBER	ARMSTRONG BAR CODE
28	BODY GASKET	106158-000	
12	BRACKET HOUSING (2)	816966-111	
8	COUPLER ASSEMBLY (Flexible) 1 PHASE 1/2X1/2	807436-000	
8	COUPLER ASSEMBLY (Flexible) 3 PHASE 1/2X5/8	806137-000	
0	COUPLER INSERT	875000-800	
22	FACEPLATE	174003-071	
3	FLANGE - 1" NPT - CAST IRON	116012-011	
5	FLANGE BOLTS - 7/16-14X1 3/4	911125-120	
4	FLANGE GASKET	105176-000	
11	FLANGE NUTS - 7/16-14 JAM	913125-100	
2	IMPELLER (Brass) - 5 1/4" DIA. (See note 5)	816302-047	
2	IMPELLER (Brass) - 4 3/4" DIA. (See note 5)	816302-051	
2	IMPELLER (Brass) - 4 3/8" DIA. (See note 5)	816302-054	
2	IMPELLER (Brass) - 4" DIA. (See note 5)	816302-057	
23	IMPELLER KEY (WOODRUFF #2)	974507-100	
27	IMPELLER NUT	106076-000	
26	IMPELLER WASHER	927311-700	
15	MECHANICAL SEAL ASSY. (Viton) (4)	816706-023	
7	RESILIENT MTD. MOT. ASSY. - 1PH/1/4HP/115V	816141-001	
7	RIGID MOUNT. MOT. ASSY. - 3PH/1/4HP/208/230/460V(6)	830781-083	
7	RESILIENT MTD. MOT. ASSY. - 1PH/1/3HP/115V	816141-002	
7	RIGID MOUNT. MOT. ASSY. - 3PH/1/3HP/208/230/460V(6)	830590-083	
10	MOTOR CAPSCREWS - 3/8-16X3/4	911121-106	
17	O RING - MODULE	961131-036	
18	O RING - REAR BEARING	961131-024	
19	O RING - SHAFT	961131-013	
24	OIL SEAL	116975-000	
21	OIL WICK (BRIDGE)	116949-000	
20	OIL WICK (ROUND)	116948-000	
1	PUMP BODY	816337-011	
9	PUMP BODY CAPS. - 5/16-1/8x3/4	911123-108	
29	SEAL BEARING ASSEMBLY (1) & (4)	816032-000	
16	SHAFT AND BEARING MODULE (3) & (4)	816999-041	

- NOTES:** (1) Seal Bearing Assembly includes Bearing Bracket, Body Gasket, Standard 106076-000 Impeller Nut, Standard 927411-700 Impeller Washer, Module, Impeller Key, "Armitte" Seal Assembly, Ceramic Seal Seat, Buna "L" (retainer) Cup, and 5/8 Ounces of Oil.
- (2) Includes Face Plate and Buna "N" Oil Seal
- (3) Includes Front Sleeve Bearing, Shaft and Sleeve Assembly, two Oil Wicks, three "O" Rings, rear Sleeve Bearing Assembly, four Mounting Screws, Impeller Key, "Armitte" Seal Assembly, Ceramic Seal Seat, Buna "L" (retainer) Cup and 5/8 ounces of oil.
- (4) The 816706-021 Mechanical Seal on the Universal SBA and the Shaft & Bearing Module must be removed and replaced with a 816706-023 Viton High Temperature Mechanical Seal.
- (5) Impeller Part Number is for a full diameter Impeller. Always specify the Pump Serial Number and if possible the diameter of the impeller being replaced.
- (6) For TEFC or Explosion Proof Motors, contact the factory.

CIRCULATOR PARTS

MODEL NUMBER 1050 1B - SIZE 5 Serial No. 6208 & Later HIGH TEMP. ALL BRONZE CONSTRUCTION (225 - 275 DEG. F)

ITEM NO.	DESCRIPTION	PART NUMBER	ARMSTRONG BAR CODE
28	BODY GASKET	106158-000	
12	BRACKET HOUSING (2)	816966-111	
8	COUPLER ASSEMBLY (Flexible) 1 PHASE 1/2X1/2	807436-000	
8	COUPLER ASSEMBLY (Flexible) 3 PHASE 1/2X5/8	806137-000	
0	COUPLER INSERT	875000-800	
22	FACEPLATE	174003-071	
3	FLANGE - 1" NPT - CAST IRON	116012-041	
5	FLANGE BOLTS - 7/16-14X1 3/4	911125-120	
4	FLANGE GASKET	105176-000	
11	FLANGE NUTS - 7/16-14 JAM	913125-100	
2	IMPELLER (Brass) - 5 1/4" DIA. (See note 5)	816302-047	
2	IMPELLER (Brass) - 4 3/4" DIA. (See note 5)	816302-051	
2	IMPELLER (Brass) - 4 3/8" DIA. (See note 5)	816302-054	
2	IMPELLER (Brass) - 4" DIA. (See note 5)	816302-057	
23	IMPELLER KEY (WOODRUFF #2)	974507-100	
27	IMPELLER NUT	106076-000	
26	IMPELLER WASHER	927311-700	
15	MECHANICAL SEAL ASSY. (Viton) (4)	816706-023	
7	RESILIENT MTD. MOT. ASSY. - 1PH/1/4HP/115V	816141-001	
7	RIGID MOUNT. MOT. ASSY. - 3PH/1/4HP/208/230/460V(6)	830781-083	
7	RESILIENT MTD. MOT. ASSY. - 1PH/1/3HP/115V	816141-002	
7	RIGID MOUNT. MOT. ASSY. - 3PH/1/3HP/208/230/460V(6)	830590-083	
10	MOTOR CAPSCREWS - 3/8-16X3/4	911121-106	
17	O RING - MODULE	961131-036	
18	O RING - REAR BEARING	961131-024	
19	O RING - SHAFT	961131-013	
24	OIL SEAL	116975-000	
21	OIL WICK (BRIDGE)	116949-000	
20	OIL WICK (ROUND)	116948-000	
1	PUMP BODY	816337-041	
9	PUMP BODY CAPS. - 5/16-1/8x3/4	911123-108	
29	SEAL BEARING ASSEMBLY (1) & (4)	816032-000	
16	SHAFT AND BEARING MODULE (3) & (4)	816999-041	

- NOTES:** (1) Seal Bearing Assembly includes Bearing Bracket, Body Gasket, Standard 106076-000 Impeller Nut, Standard 927411-700 Impeller Washer, Module, Impeller Key, "Armite" Seal Assembly, Ceramic Seal Seat, Buna "L" (retainer) Cup, and 5/8 Ounces of Oil.
- (2) Includes Face Plate and Buna "N" Oil Seal
- (3) Includes Front Sleeve Bearing, Shaft and Sleeve Assembly, two Oil Wicks, three "O" Rings, rear Sleeve Bearing Assembly, four Mounting Screws, Impeller Key, "Armite" Seal Assembly, Ceramic Seal Seat, Buna "L" (retainer) Cup and 5/8 ounces of oil.
- (4) The 816706-021 Mechanical Seal on the Universal SBA and the Shaft & Bearing Module must be removed and replaced with a 816706-023 Viton High Temperature Mechanical Seal.
- (5) Impeller Part Number is for a full diameter Impeller. Always specify the Pump Serial Number and if possible the diameter of the impeller being replaced.
- (6) For TEFC or Explosion Proof Motors, contact the factory.

CIRCULATOR PARTS

MODEL NUMBER 1050 11/4B - SIZE 5 Serial No. 6208 & Later STANDARD AND BRONZE FITTED CONSTRUCTION

ITEM NO.	DESCRIPTION	PART NUMBER	ARMSTRONG BAR CODE
28	BODY GASKET	106158-000	
12	BRACKET HOUSING (2)	816966-111	
8	COUPLER ASSEMBLY (Flexible) 1 PHASE 1/2X1/2	807436-000	
8	COUPLER ASSEMBLY (Flexible) 3 PHASE 1/2X5/8	806137-000	
0	COUPLER INSERT	875000-800	
22	FACEPLATE	174003-071	
3	FLANGE - 1 1/4" NPT - CAST IRON	116011-011	
5	FLANGE BOLTS - 7/16-14X1 3/4	911125-120	
4	FLANGE GASKET	105176-000	
11	FLANGE NUTS - 7/16-14 JAM	913125-100	
2	IMPELLER - 5 1/4" DIA. (See note 4)	816302-317	
2	IMPELLER - 4 3/4" DIA. (See note 4)	816302-321	
2	IMPELLER - 4 3/8" DIA. (See note 4)	816302-324	
2	IMPELLER - 4" DIA. (See note 4)	816302-327	
23	IMPELLER KEY (WOODRUFF #2)	974507-100	
27	IMPELLER NUT	106076-000	
26	IMPELLER WASHER	927311-700	
15	MECHANICAL SEAL ASSEMBLY	816706-021	
7	RESILIENT MTD. MOT. ASSY. - 1PH/1/4HP/115V	816141-001	
7	RIGID MOUNT. MOT. ASSY. - 3PH/1/4HP/208/230/460V(5)	830781-083	
7	RESILIENT MTD. MOT. ASSY. - 1PH/1/3HP/115V	816141-002	
7	RIGID MOUNT. MOT. ASSY. - 3PH/1/3HP/208/230/460V(5)	830590-083	
7	RESILIENT MTD. MOT. ASSY. - 1PH/1/2HP/115V	811757-001	
7	RIGID MOUNT. MOT. ASSY. - 3PH/1/2HP/208/230/460V(5)	831011-083	
7	RIGID MOUNT. MOT. ASSY. - 3PH/1/2HP/575V(5)	831011-083	
10	MOTOR CAPSCREWS - 3/8-16X3/4	911121-106	
17	O RING - MODULE	961131-036	
18	O RING - REAR BEARING	961131-024	
19	O RING - SHAFT	961131-013	
24	OIL SEAL	116975-000	
21	OIL WICK (BRIDGE)	116949-000	
20	OIL WICK (ROUND)	116948-000	
1	PUMP BODY	816337-011	
9	PUMP BODY CAPS. - 5/16-1/8x3/4	911123-108	
29	SEAL BEARING ASSEMBLY (1)	816032-000	
16	SHAFT AND BEARING MODULE (3)	816999-041	

- NOTES:** 1) Seal Bearing Assembly includes Bearing Bracket, Body Gasket, Standard 106076-000 Impeller Nut, Standard 927411-700 Impeller Washer, Module, Impeller Key, "Armite" Seal Assembly, Ceramic Seal Seat, Buna "L" (retainer) Cup, and 5/8 Ounces of Oil.
(2) Includes Face Plate and Buna "N" Oil Seal
(3) Includes Front Sleeve Bearing, Shaft and Sleeve Assembly, two Oil Wicks, three "O" Rings, rear Sleeve Bearing Assembly, four Mounting Screws, Impeller Key, "Armite" Seal Assembly, Ceramic Seal Seat, Buna "L" (retainer) Cup and 5/8 ounces of oil.
(4) Impeller Part Numbers are for stock diameter Impellers. For Impeller Diameters not listed, please contact the factory.
(5) For TEFC or Explosion Proof Motors, please contact the factory.

CIRCULATOR PARTS

MODEL NUMBER 1050 11/4B - SIZE 5 Serial No. 6208 & Later ALL BRONZE CONSTRUCTION

ITEM NO.	DESCRIPTION	PART NUMBER	ARMSTRONG BAR CODE
28	BODY GASKET	106158-000	
12	BRACKET HOUSING (2)	816966-111	
8	COUPLER ASSEMBLY (Flexible) 1 PHASE 1/2X1/2	807436-000	
8	COUPLER ASSEMBLY (Flexible) 3 PHASE 1/2X5/8	806137-000	
0	COUPLER INSERT	875000-800	
22	FACEPLATE	174003-071	
3	FLANGE - 1 1/4" NPT - BRONZE	116011-041	
5	FLANGE BOLTS - 7/16-14X1 3/4	911125-120	
4	FLANGE GASKET	105176-000	
11	FLANGE NUTS - 7/16-14 JAM	913125-100	
2	IMPELLER - 5 1/4" DIA. (See note 4)	816302-317	
2	IMPELLER - 4 3/4" DIA. (See note 4)	816302-321	
2	IMPELLER - 4 3/8" DIA. (See note 4)	816302-324	
2	IMPELLER - 4" DIA. (See note 4)	816302-327	
23	IMPELLER KEY (WOODRUFF #2)	974507-100	
27	IMPELLER NUT	106076-000	
26	IMPELLER WASHER	927311-700	
15	MECHANICAL SEAL ASSEMBLY	816706-021	
7	RESILIENT MTD. MOT. ASSY. - 1PH/1/4HP/115V	816141-001	
7	RIGID MOUNT. MOT. ASSY. - 3PH/1/4HP/208/230/460V(5)	830781-083	
7	RESILIENT MTD. MOT. ASSY. - 1PH/1/3HP/115V	816141-002	
7	RIGID MOUNT. MOT. ASSY. - 3PH/1/3HP/208/230/460V(5)	830590-083	
7	RESILIENT MTD. MOT. ASSY. - 1PH/1/2HP/115V	811757-001	
7	RIGID MOUNT. MOT. ASSY. - 3PH/1/2HP/208/230/460V(5)	831011-083	
7	RIGID MOUNT. MOT. ASSY. - 3PH/1/2HP/575V(5)	831011-083	
10	MOTOR CAPSCREWS - 3/8-16X3/4	911121-106	
17	O RING - MODULE	961131-036	
18	O RING - REAR BEARING	961131-024	
19	O RING - SHAFT	961131-013	
24	OIL SEAL	116975-000	
21	OIL WICK (BRIDGE)	116949-000	
20	OIL WICK (ROUND)	116948-000	
1	PUMP BODY	816337-041	
9	PUMP BODY CAPS. - 5/16-1/8x3/4	911123-108	
29	SEAL BEARING ASSEMBLY (1)	816032-000	
16	SHAFT AND BEARING MODULE (3)	816999-041	

- NOTES:** (1) Seal Bearing Assembly includes Bearing Bracket, Body Gasket, Standard 106076-000 Impeller Nut, Standard 927411-700 Impeller Washer, Module, Impeller Key, "Armitite" Seal Assembly, Ceramic Seal Seat, Buna "L" (retainer) Cup, and 5/8 Ounces of Oil.
(2) Includes Face Plate and Buna "N" Oil Seal
(3) Includes Front Sleeve Bearing, Shaft and Sleeve Assembly, two Oil Wicks, three "O" Rings, rear Sleeve Bearing Assembly, four Mounting Screws, Impeller Key, "Armitite" Seal Assembly, Ceramic Seal Seat, Buna "L" (retainer) Cup and 5/8 ounces of oil.
(4) Impeller Part Numbers are for stock diameter Impellers. For Impeller Diameters not listed, please contact the factory.
(5) For TEFC or Explosion Proof Motors, contact the factory.

CIRCULATOR PARTS

MODEL NUMBER 1050 11/4B - SIZE 5 Serial No. 6208 & Later HIGH TEMP. STANDARD CONSTRUCTION (225 - 275 DEG. F)

ITEM NO.	DESCRIPTION	PART NUMBER	ARMSTRONG BAR CODE
28	BODY GASKET	106158-000	
12	BRACKET HOUSING (2)	816966-111	
8	COUPLER ASSEMBLY (Flexible) 1 PHASE 1/2X1/2	807436-000	
8	COUPLER ASSEMBLY (Flexible) 3 PHASE 1/2X5/8	806137-000	
0	COUPLER INSERT	875000-800	
22	FACEPLATE	174003-071	
3	FLANGE - 1 1/4" NPT - CAST IRON	116011-011	
5	FLANGE BOLTS - 7/16-14X1 3/4	911125-120	
4	FLANGE GASKET	105176-000	
11	FLANGE NUTS - 7/16-14 JAM	913125-100	
2	IMPELLER (Steel) - 5 1/4" DIA. (See note 5)	816302-017	
2	IMPELLER (Steel) - 4 3/4" DIA. (See note 5)	816302-021	
2	IMPELLER (Steel) - 4 3/8" DIA. (See note 5)	816302-024	
2	IMPELLER (Steel) - 4" DIA. (See note 5)	816302-027	
23	IMPELLER KEY (WOODRUFF #2)	974507-100	
27	IMPELLER NUT	106076-000	
26	IMPELLER WASHER	927311-700	
15	MECHANICAL SEAL ASSY. (Viton) (4)	816706-023	
7	RESILIENT MTD. MOT. ASSY. - 1PH/1/4HP/115V	816141-001	
7	RIGID MOUNT. MOT. ASSY. - 3PH/1/4HP/208/230/460V(6)	830781-083	
7	RESILIENT MTD. MOT. ASSY. - 1PH/1/3HP/115V	816141-002	
7	RIGID MOUNT. MOT. ASSY. - 3PH/1/3HP/208/230/460V(5)	830590-083	
7	RESILIENT MTD. MOT. ASSY. - 1PH/1/2HP/115V	811757-001	
7	RIGID MOUNT. MOT. ASSY. - 3PH/1/2HP/208/230/460V(5)	831011-083	
7	RIGID MOUNT. MOT. ASSY. - 3PH/1/2HP/575V(5)	831011-083	
10	MOTOR CAPSCREWS - 3/8-16X3/4	911121-106	
17	O RING - MODULE	961131-036	
18	O RING - REAR BEARING	961131-024	
19	O RING - SHAFT	961131-013	
24	OIL SEAL	116975-000	
21	OIL WICK (BRIDGE)	116949-000	
20	OIL WICK (ROUND)	116948-000	
1	PUMP BODY	816337-011	
9	PUMP BODY CAPS. - 5/16-1/8x3/4	911123-108	
29	SEAL BEARING ASSEMBLY (1) & (4)	816032-000	
16	SHAFT AND BEARING MODULE (3) & (4)	816999-041	

- NOTES:** (1) Seal Bearing Assembly includes Bearing Bracket, Body Gasket, Standard 106076-000 Impeller Nut, Standard 927411-700 Impeller Washer, Module, Impeller Key, "Armite" Seal Assembly, Ceramic Seal Seat, Buna "L" (retainer) Cup, and 5/8 Ounces of Oil.
(2) Includes Face Plate and Buna "N" Oil Seal
(3) Includes Front Sleeve Bearing, Shaft and Sleeve Assembly, two Oil Wicks, three "O" Rings, rear Sleeve Bearing Assembly, four Mounting Screws, Impeller Key, "Armite" Seal Assembly, Ceramic Seal Seat, Buna "L" (retainer) Cup and 5/8 ounces of oil.
(4) The 816706-021 Mechanical Seal on the Universal SBA and the Shaft & Bearing Module must be removed and replaced with a 816706-023 Viton High Temperature Mechanical Seal.
(5) Impeller Part Number is for a full diameter Impeller. Always specify the Pump Serial Number and if possible the diameter of the impeller being replaced.
(6) For TEFC or Explosion Proof Motors, contact the factory.

CIRCULATOR PARTS

MODEL NUMBER 1050 11/4B - SIZE 5 Serial No. 6208 & Later HIGH TEMP. BRONZE FITTED CONSTRUCTION (225 - 275 DEG. F)

ITEM NO.	DESCRIPTION	PART NUMBER	ARMSTRONG BAR CODE
28	BODY GASKET	106158-000	
12	BRACKET HOUSING (2)	816966-111	
8	COUPLER ASSEMBLY (Flexible) 1 PHASE 1/2X1/2	807436-000	
8	COUPLER ASSEMBLY (Flexible) 3 PHASE 1/2X5/8	806137-000	
0	COUPLER INSERT	875000-800	
22	FACEPLATE	174003-071	
3	FLANGE - 1 1/4" NPT - CAST IRON	116011-011	
5	FLANGE BOLTS - 7/16-14X1 3/4	911125-120	
4	FLANGE GASKET	105176-000	
11	FLANGE NUTS - 7/16-14 JAM	913125-100	
2	IMPELLER (Brass) - 5 1/4" DIA. (See note 5)	816302-047	
2	IMPELLER (Brass) - 4 3/4" DIA. (See note 5)	816302-051	
2	IMPELLER (Brass) - 4 3/8" DIA. (See note 5)	816302-054	
2	IMPELLER (Brass) - 4" DIA. (See note 5)	816302-057	
23	IMPELLER KEY (WOODRUFF #2)	974507-100	
27	IMPELLER NUT	106076-000	
26	IMPELLER WASHER	927311-700	
15	MECHANICAL SEAL ASSY. (Viton) (4)	816706-023	
7	RESILIENT MTD. MOT. ASSY. - 1PH/1/4HP/115V	816141-001	
7	RIGID MOUNT. MOT. ASSY. - 3PH/1/4HP/208/230/460V(6)	830781-083	
7	RESILIENT MTD. MOT. ASSY. - 1PH/1/3HP/115V	816141-002	
7	RIGID MOUNT. MOT. ASSY. - 3PH/1/3HP/208/230/460V(5)	830590-083	
7	RESILIENT MTD. MOT. ASSY. - 1PH/1/2HP/115V	811757-001	
7	RIGID MOUNT. MOT. ASSY. - 3PH/1/2HP/208/230/460V(5)	831011-083	
7	RIGID MOUNT. MOT. ASSY. - 3PH/1/2HP/575V(5)	831011-083	
10	MOTOR CAPSCREWS - 3/8-16X3/4	911121-106	
17	O RING - MODULE	961131-036	
18	O RING - REAR BEARING	961131-024	
19	O RING - SHAFT	961131-013	
24	OIL SEAL	116975-000	
21	OIL WICK (BRIDGE)	116949-000	
20	OIL WICK (ROUND)	116948-000	
1	PUMP BODY	816337-011	
9	PUMP BODY CAPS. - 5/16-1/8x3/4	911123-108	
29	SEAL BEARING ASSEMBLY (1) & (4)	816032-000	
16	SHAFT AND BEARING MODULE (3) & (4)	816999-041	

- NOTES:** (1) Seal Bearing Assembly includes Bearing Bracket, Body Gasket, Standard 106076-000 Impeller Nut, Standard 927411-700 Impeller Washer, Module, Impeller Key, "Armité" Seal Assembly, Ceramic Seal Seat, Buna "L" (retainer) Cup, and 5/8 Ounces of Oil.
- (2) Includes Face Plate and Buna "N" Oil Seal
- (3) Includes Front Sleeve Bearing, Shaft and Sleeve Assembly, two Oil Wicks, three "O" Rings, rear Sleeve Bearing Assembly, four Mounting Screws, Impeller Key, "Armité" Seal Assembly, Ceramic Seal Seat, Buna "L" (retainer) Cup and 5/8 ounces of oil.
- (4) The 816706-021 Mechanical Seal on the Universal SBA and the Shaft & Bearing Module must be removed and replaced with a 816706-023 Viton High Temperature Mechanical Seal.
- (5) Impeller Part Number is for a full diameter Impeller. Always specify the Pump Serial Number and if possible the diameter of the impeller being replaced.
- (6) For TEFC or Explosion Proof Motors, contact the factory.

CIRCULATOR PARTS

MODEL NUMBER 1050 1 1/4B - SIZE 5 Serial No. 6208 & Later HIGH TEMP. ALL BRONZE CONSTRUCTION (225 - 275 DEG. F)

ITEM NO.	DESCRIPTION	PART NUMBER	ARMSTRONG BAR CODE
28	BODY GASKET	106158-000	
12	BRACKET HOUSING (2)	816966-111	
8	COUPLER ASSEMBLY (Flexible) 1 PHASE 1/2X1/2	807436-000	
8	COUPLER ASSEMBLY (Flexible) 3 PHASE 1/2X5/8	806137-000	
0	COUPLER INSERT	875000-800	
22	FACEPLATE	174003-071	
3	FLANGE - 1 1/4" NPT - BRONZE	116011-041	
5	FLANGE BOLTS - 7/16-14X1 3/4	911125-120	
4	FLANGE GASKET	105176-000	
11	FLANGE NUTS - 7/16-14 JAM	913125-100	
2	IMPELLER (Brass) - 5 1/4" DIA. (See note 5)	816302-047	
2	IMPELLER (Brass) - 4 3/4" DIA. (See note 5)	816302-051	
2	IMPELLER (Brass) - 4 3/8" DIA. (See note 5)	816302-054	
2	IMPELLER (Brass) - 4" DIA. (See note 5)	816302-057	
23	IMPELLER KEY (WOODRUFF #2)	974507-100	
27	IMPELLER NUT	106076-000	
26	IMPELLER WASHER	927311-700	
15	MECHANICAL SEAL ASSY. (Viton) (4)	816706-023	
7	RESILIENT MTD. MOT. ASSY. - 1PH/1/4HP/115V	816141-001	
7	RIGID MOUNT. MOT. ASSY. - 3PH/1/4HP/208/230/460V(6)	830781-083	
7	RESILIENT MTD. MOT. ASSY. - 1PH/1/3HP/115V	816141-002	
7	RIGID MOUNT. MOT. ASSY. - 3PH/1/3HP/208/230/460V(5)	830590-083	
7	RESILIENT MTD. MOT. ASSY. - 1PH/1/2HP/115V	811757-001	
7	RIGID MOUNT. MOT. ASSY. - 3PH/1/2HP/208/230/460V(5)	831011-083	
7	RIGID MOUNT. MOT. ASSY. - 3PH/1/2HP/575V(5)	831011-083	
10	MOTOR CAPSCREWS - 3/8-16X3/4	911121-106	
17	O RING - MODULE	961131-036	
18	O RING - REAR BEARING	961131-024	
19	O RING - SHAFT	961131-013	
24	OIL SEAL	116975-000	
21	OIL WICK (BRIDGE)	116949-000	
20	OIL WICK (ROUND)	116948-000	
1	PUMP BODY	816337-041	
9	PUMP BODY CAPS. - 5/16-1/8x3/4	911123-108	
29	SEAL BEARING ASSEMBLY (1) & (4)	816032-000	
16	SHAFT AND BEARING MODULE (3) & (4)	816999-041	

- NOTES:** (1) Seal Bearing Assembly includes Bearing Bracket, Body Gasket, Standard 106076-000 Impeller Nut, Standard 927411-700 Impeller Washer, Module, Impeller Key, "Armite" Seal Assembly, Ceramic Seal Seat, Buna "L" (retainer) Cup, and 5/8 Ounces of Oil.
- (2) Includes Face Plate and Buna "N" Oil Seal
- (3) Includes Front Sleeve Bearing, Shaft and Sleeve Assembly, two Oil Wicks, three "O" Rings, rear Sleeve Bearing Assembly, four Mounting Screws, Impeller Key, "Armite" Seal Assembly, Ceramic Seal Seat, Buna "L" (retainer) Cup and 5/8 ounces of oil.
- (4) The 816706-021 Mechanical Seal on the Universal SBA and the Shaft & Bearing Module must be removed and replaced with a 816706-023 Viton High Temperature Mechanical Seal.
- (5) Impeller Part Number is for a full diameter Impeller. Always specify the Pump Serial Number and if possible the diameter of the impeller being replaced.
- (6) For TEFC or Explosion Proof Motors, contact the factory.

CIRCULATOR PARTS

MODEL NUMBER 1050 1 1/2B - SIZE 5 Serial No. 6208 & Later STANDARD AND BRONZE FITTED CONSTRUCTION

ITEM NO.	DESCRIPTION	PART NUMBER	ARMSTRONG BAR CODE
28	BODY GASKET	106158-000	
12	BRACKET HOUSING (2)	816966-111	
8	COUPLER ASSEMBLY (Flexible) 1 PHASE 1/2X1/2	807436-000	
8	COUPLER ASSEMBLY (Flexible) 3 PHASE 1/2X5/8	806137-000	
0	COUPLER INSERT	875000-800	
22	FACEPLATE	174003-071	
3	FLANGE - 1 1/2" NPT - CAST IRON	116009-011	
5	FLANGE BOLTS - 7/16-14X1 3/4	911125-120	
4	FLANGE GASKET	105176-000	
11	FLANGE NUTS - 7/16-14 JAM	913125-100	
2	IMPELLER - 5 1/4" DIA. (See note 4)	816303-317	
2	IMPELLER - 4 3/4" DIA. (See note 4)	816303-321	
2	IMPELLER - 4 3/8" DIA. (See note 4)	816303-324	
2	IMPELLER - 4" DIA. (See note 4)	816303-327	
23	IMPELLER KEY (WOODRUFF #2)	974507-100	
27	IMPELLER NUT	106076-000	
26	IMPELLER WASHER	927311-700	
15	MECHANICAL SEAL ASSEMBLY	816706-021	
7	RESILIENT MTD. MOT. ASSY. - 1PH/1/4HP/115V	816141-001	
7	RIGID MOUNT. MOT. ASSY. - 3PH/1/4HP/208/230/460V(5)	830781-083	
7	RESILIENT MTD. MOT. ASSY. - 1PH/1/3HP/115V	816141-002	
7	RIGID MOUNT. MOT. ASSY. - 3PH/1/3HP/208/230/460V(5)	830590-083	
7	RESILIENT MTD. MOT. ASSY. - 1PH/1/2HP/115/230V	811757-001	
7	RIGID MOUNT. MOT. ASSY. - 3PH/1/2HP/208/230/460V(5)	831011-083	
7	RIGID MOUNT. MOT. ASSY. - 3PH/1/2HP/575V(5)	831011-083	
7	RESILIENT MTD. MOT. ASSY. - 1PH/3/4HP/115/230V	811757-002	
7	RIGID MOUNT. MOT. ASSY. - 3PH/3/4HP/208/230/460V(5)	831012-083	
7	RIGID MOUNT. MOT. ASSY. - 3PH/3/4HP/575V(5)	811757-006	
10	MOTOR CAPSCREWS - 3/8-16X3/4	911121-106	
17	O RING - MODULE	961131-036	
18	O RING - REAR BEARING	961131-024	
19	O RING - SHAFT	961131-013	
24	OIL SEAL	116975-000	
21	OIL WICK (BRIDGE)	116949-000	
20	OIL WICK (ROUND)	116948-000	
1	PUMP BODY	816337-011	
9	PUMP BODY CAPS. - 5/16-1/8x3/4	911123-108	
29	SEAL BEARING ASSEMBLY (1) & (4)	816032-000	
16	SHAFT AND BEARING MODULE (3) & (4)	816999-041	

- NOTES:** (1) Seal Bearing Assembly includes Bearing Bracket, Body Gasket, Standard 106076-000 Impeller Nut, Standard 927411-700 Impeller Washer, Module, Impeller Key, "Armite" Seal Assembly, Ceramic Seal Seat, Buna "L" (retainer) Cup, and 5/8 Ounces of Oil.
- (2) Includes Face Plate and Buna "N" Oil Seal
- (3) Includes Front Sleeve Bearing, Shaft and Sleeve Assembly, two Oil Wicks, three "O" Rings, rear Sleeve Bearing Assembly, four Mounting Screws, Impeller Key, "Armite" Seal Assembly, Ceramic Seal Seat, Buna "L" (retainer) Cup and 5/8 ounces of oil.
- (4) Impeller Part Numbers are for stock diameter Impellers. For Impeller Diameters not listed, please contact the factory.
- (5) For TEFC or Explosion Proof Motors, please contact the factory.

CIRCULATOR PARTS

MODEL NUMBER 1050 11/2B - SIZE 5 Serial No. 6208 & Later ALL BRONZE CONSTRUCTION

ITEM NO.	DESCRIPTION	PART NUMBER	ARMSTRONG BAR CODE
28	BODY GASKET	106158-000	
12	BRACKET HOUSING (2)	816966-111	
8	COUPLER ASSEMBLY (Flexible) 1 PHASE 1/2X1/2	807436-000	
8	COUPLER ASSEMBLY (Flexible) 3 PHASE 1/2X5/8	806137-000	
0	COUPLER INSERT	875000-800	
22	FACEPLATE	174003-071	
3	FLANGE - 1 1/2" NPT - BRONZE	116009-041	
5	FLANGE BOLTS - 7/16-14X1 3/4	911125-120	
4	FLANGE GASKET	105176-000	
11	FLANGE NUTS - 7/16-14 JAM	913125-100	
2	IMPELLER - 5 1/4" DIA. (See note 4)	816303-317	
2	IMPELLER - 4 3/4" DIA. (See note 4)	816303-321	
2	IMPELLER - 4 3/8" DIA. (See note 4)	816303-324	
2	IMPELLER - 4" DIA. (See note 4)	816303-327	
23	IMPELLER KEY (WOODRUFF #2)	974507-100	
27	IMPELLER NUT	106076-000	
26	IMPELLER WASHER	927311-700	
15	MECHANICAL SEAL ASSEMBLY	816706-021	
7	RESILIENT MTD. MOT. ASSY. - 1PH/1/4HP/115V	816141-001	
7	RIGID MOUNT. MOT. ASSY. - 3PH/1/4HP/208/230/460V(5)	830781-083	
7	RESILIENT MTD. MOT. ASSY. - 1PH/1/3HP/115V	816141-002	
7	RIGID MOUNT. MOT. ASSY. - 3PH/1/3HP/208/230/460V(5)	830590-083	
7	RESILIENT MTD. MOT. ASSY. - 1PH/1/2HP/115/230V	811757-001	
7	RIGID MOUNT. MOT. ASSY. - 3PH/1/2HP/208/230/460V(5)	831011-083	
7	RIGID MOUNT. MOT. ASSY. - 3PH/1/2HP/575V(5)	831011-083	
7	RESILIENT MTD. MOT. ASSY. - 1PH/3/4HP/115/230V	811757-002	
7	RIGID MOUNT. MOT. ASSY. - 3PH/3/4HP/208/230/460V(5)	831012-083	
7	RIGID MOUNT. MOT. ASSY. - 3PH/3/4HP/575V(5)	811757-006	
10	MOTOR CAPSCREWS - 3/8-16X3/4	911121-106	
17	O RING - MODULE	961131-036	
18	O RING - REAR BEARING	961131-024	
19	O RING - SHAFT	961131-013	
24	OIL SEAL	116975-000	
21	OIL WICK (BRIDGE)	116949-000	
20	OIL WICK (ROUND)	116948-000	
1	PUMP BODY	816337-041	
9	PUMP BODY CAPS. - 5/16-1/8x3/4	911123-108	
29	SEAL BEARING ASSEMBLY (1) & (4)	816032-000	
16	SHAFT AND BEARING MODULE (3) & (4)	816999-041	

- NOTES:** (1) Seal Bearing Assembly includes Bearing Bracket, Body Gasket, Standard 106076-000 Impeller Nut, Standard 927411-700 Impeller Washer, Module, Impeller Key, "Armite" Seal Assembly, Ceramic Seal Seat, Buna "L" (retainer) Cup, and 5/8 Ounces of Oil.
- (2) Includes Face Plate and Buna "N" Oil Seal
- (3) Includes Front Sleeve Bearing, Shaft and Sleeve Assembly, two Oil Wicks, three "O" Rings, rear Sleeve Bearing Assembly, four Mounting Screws, Impeller Key, "Armite" Seal Assembly, Ceramic Seal Seat, Buna "L" (retainer) Cup and 5/8 ounces of oil.
- (4) Impeller Part Numbers are for stock diameter Impellers. For Impeller Diameters not listed, please contact the factory.
- (5) For TEFC or Explosion Proof Motors, contact the factory.

CIRCULATOR PARTS

MODEL NUMBER 1050 11/2B - SIZE 5 Serial No. 6208 & Later HIGH TEMP. STANDARD CONSTRUCTION (225 - 275 DEG. F)

ITEM NO.	DESCRIPTION	PART NUMBER	ARMSTRONG BAR CODE
28	BODY GASKET	106158-000	
12	BRACKET HOUSING (2)	816966-111	
8	COUPLER ASSEMBLY (Flexible) 1 PHASE 1/2X1/2	807436-000	
8	COUPLER ASSEMBLY (Flexible) 3 PHASE 1/2X5/8	806137-000	
0	COUPLER INSERT	875000-800	
22	FACEPLATE	174003-071	
3	FLANGE - 1 1/2" NPT - CAST IRON	116009-011	
5	FLANGE BOLTS - 7/16-14X1 3/4	911125-120	
4	FLANGE GASKET	105176-000	
11	FLANGE NUTS - 7/16-14 JAM	913125-100	
2	IMPELLER (Steel) - 5 1/4" DIA. (See note 5)	816303-017	
2	IMPELLER (Steel) - 4 3/4" DIA. (See note 5)	816303-021	
2	IMPELLER (Steel) - 4 3/8" DIA. (See note 5)	816303-024	
2	IMPELLER (Steel) - 4" DIA. (See note 5)	816303-027	
23	IMPELLER KEY (WOODRUFF #2)	974507-100	
27	IMPELLER NUT	106076-000	
26	IMPELLER WASHER	927311-700	
15	MECHANICAL SEAL ASSY. (Viton) (4)	816706-023	
7	RESILIENT MTD. MOT. ASSY. - 1PH/1/4HP/115V	816141-001	
7	RIGID MOUNT. MOT. ASSY. - 3PH/1/4HP/208/230/460V(6)	830781-083	
7	RESILIENT MTD. MOT. ASSY. - 1PH/1/3HP/115V	816141-002	
7	RIGID MOUNT. MOT. ASSY. - 3PH/1/3HP/208/230/460V(6)	830590-083	
7	RESILIENT MTD. MOT. ASSY. - 1PH/1/2HP/115/230V	811757-001	
7	RIGID MOUNT. MOT. ASSY. - 3PH/1/2HP/208/230/460V (6)	831011-083	
7	RIGID MOUNT. MOT. ASSY. - 3PH/1/2HP/575V(6)	831011-083	
7	RESILIENT MTD. MOT. ASSY. - 1PH/3/4HP/115/230V	811757-002	
7	RIGID MOUNT. MOT. ASSY. - 3PH/3/4HP/208/230/460V(6)	831012-083	
7	RIGID MOUNT. MOT. ASSY. - 3PH/3/4HP/575V(6)	811757-006	
10	MOTOR CAPSCREWS - 3/8-16X3/4	911121-106	
17	O RING - MODULE	961131-036	
18	O RING - REAR BEARING	961131-024	
19	O RING - SHAFT	961131-013	
24	OIL SEAL	116975-000	
21	OIL WICK (BRIDGE)	116949-000	
20	OIL WICK (ROUND)	116948-000	
1	PUMP BODY	816337-011	
9	PUMP BODY CAPS. - 5/16-1/8x3/4	911123-108	
29	SEAL BEARING ASSEMBLY (1) & (4)	816032-000	
16	SHAFT AND BEARING MODULE (3) & (4)	816999-041	

- NOTES:** (1) Seal Bearing Assembly includes Bearing Bracket, Body Gasket, Standard 106076-000 Impeller Nut, Standard 927411-700 Impeller Washer, Module, Impeller Key, "Armite" Seal Assembly, Ceramic Seal Seat, Buna "L" (retainer) Cup, and 5/8 Ounces of Oil.
- (2) Includes Face Plate and Buna "N" Oil Seal
- (3) Includes Front Sleeve Bearing, Shaft and Sleeve Assembly, two Oil Wicks, three "O" Rings, rear Sleeve Bearing Assembly, four Mounting Screws, Impeller Key, "Armite" Seal Assembly, Ceramic Seal Seat, Buna "L" (retainer) Cup and 5/8 ounces of oil.
- (4) The 816706-021 Mechanical Seal on the Universal SBA and the Shaft & Bearing Module must be removed and replaced with a 816706-023 Viton High Temperature Mechanical Seal.
- (5) Impeller Part Number is for a full diameter Impeller. Always specify the Pump Serial Number and if possible the diameter of the impeller being replaced.
- (6) For TEFC or Explosion Proof Motors, contact the factory.

CIRCULATOR PARTS

MODEL NUMBER 1050 1 1/2B - SIZE 5 Serial No. 6208 & Later HIGH TEMP. BRONZE FITTED CONSTRUCTION (225 - 275 DEG. F)

ITEM NO.	DESCRIPTION	PART NUMBER	ARMSTRONG BAR CODE
28	BODY GASKET	106158-000	
12	BRACKET HOUSING (2)	816966-111	
8	COUPLER ASSEMBLY (Flexible) 1 PHASE 1/2X1/2	807436-000	
8	COUPLER ASSEMBLY (Flexible) 3 PHASE 1/2X5/8	806137-000	
0	COUPLER INSERT	875000-800	
22	FACEPLATE	174003-071	
3	FLANGE - 1 1/2" NPT - CAST IRON	116009-011	
5	FLANGE BOLTS - 7/16-14X1 3/4	911125-120	
4	FLANGE GASKET	105176-000	
11	FLANGE NUTS - 7/16-14 JAM	913125-100	
2	IMPELLER (Brass) - 5 1/4" DIA. (See note 5)	816303-047	
2	IMPELLER (Brass) - 4 3/4" DIA. (See note 5)	816303-051	
2	IMPELLER (Brass) - 4 3/8" DIA. (See note 5)	816303-054	
2	IMPELLER (Brass) - 4" DIA. (See note 5)	816303-057	
23	IMPELLER KEY (WOODRUFF #2)	974507-100	
27	IMPELLER NUT	106076-000	
26	IMPELLER WASHER	927311-700	
15	MECHANICAL SEAL ASSY. (Viton) (4)	816706-023	
7	RESILIENT MTD. MOT. ASSY. - 1PH/1/4HP/115V	816141-001	
7	RIGID MOUNT. MOT. ASSY. - 3PH/1/4HP/208/230/460V(6)	830781-083	
7	RESILIENT MTD. MOT. ASSY. - 1PH/1/3HP/115V	816141-002	
7	RIGID MOUNT. MOT. ASSY. - 3PH/1/3HP/208/230/460V(6)	830590-083	
7	RESILIENT MTD. MOT. ASSY. - 1PH/1/2HP/115/230V	811757-001	
7	RIGID MOUNT. MOT. ASSY. - 3PH/1/2HP/208/230/460V(6)	831011-083	
7	RIGID MOUNT. MOT. ASSY. - 3PH/1/2HP/575V(6)	831011-083	
7	RESILIENT MTD. MOT. ASSY. - 1PH/3/4HP/115/230V	811757-002	
7	RIGID MOUNT. MOT. ASSY. - 3PH/3/4HP/208/230/460V(6)	831012-083	
7	RIGID MOUNT. MOT. ASSY. - 3PH/3/4HP/575V(6)	811757-006	
10	MOTOR CAPSCREWS - 3/8-16X3/4	911121-106	
17	O RING - MODULE	961131-036	
18	O RING - REAR BEARING	961131-024	
19	O RING - SHAFT	961131-013	
24	OIL SEAL	116975-000	
21	OIL WICK (BRIDGE)	116949-000	
20	OIL WICK (ROUND)	116948-000	
1	PUMP BODY	816337-011	
9	PUMP BODY CAPS. - 5/16-1/8x3/4	911123-108	
29	SEAL BEARING ASSEMBLY (1) & (4)	816032-000	
16	SHAFT AND BEARING MODULE (3) & (4)	816999-041	

- NOTES:** (1) Seal Bearing Assembly includes Bearing Bracket, Body Gasket, Standard 106076-000 Impeller Nut, Standard 927411-700 Impeller Washer, Module, Impeller Key, "Armité" Seal Assembly, Ceramic Seal Seat, Buna "L" (retainer) Cup, and 5/8 Ounces of Oil.
- (2) Includes Face Plate and Buna "N" Oil Seal
- (3) Includes Front Sleeve Bearing, Shaft and Sleeve Assembly, two Oil Wicks, three "O" Rings, rear Sleeve Bearing Assembly, four Mounting Screws, Impeller Key, "Armité" Seal Assembly, Ceramic Seal Seat, Buna "L" (retainer) Cup and 5/8 ounces of oil.
- (4) The 816706-021 Mechanical Seal on the Universal SBA and the Shaft & Bearing Module must be removed and replaced with a 816706-023 Viton High Temperature Mechanical Seal.
- (5) Impeller Part Number is for a full diameter Impeller. Always specify the Pump Serial Number and if possible the diameter of the impeller being replaced.
- (6) For TEFC or Explosion Proof Motors, contact the factory.

CIRCULATOR PARTS

MODEL NUMBER 1050 1 1/2B - SIZE 5 Serial No. 6208 & Later HIGH TEMP. ALL BRONZE CONSTRUCTION (225 - 275 DEG. F)

ITEM NO.	DESCRIPTION	PART NUMBER	ARMSTRONG BAR CODE
28	BODY GASKET	106158-000	
12	BRACKET HOUSING (2)	816966-111	
8	COUPLER ASSEMBLY (Flexible) 1 PHASE 1/2X1/2	807436-000	
8	COUPLER ASSEMBLY (Flexible) 3 PHASE 1/2X5/8	806137-000	
0	COUPLER INSERT	875000-800	
22	FACEPLATE	174003-071	
3	FLANGE - 1 1/2" NPT - BRONZE	116009-041	
5	FLANGE BOLTS - 7/16-14X1 3/4	911125-120	
4	FLANGE GASKET	105176-000	
11	FLANGE NUTS - 7/16-14 JAM	913125-100	
2	IMPELLER (Brass) - 5 1/4" DIA. (See note 5)	816303-047	
2	IMPELLER (Brass) - 4 3/4" DIA. (See note 5)	816303-051	
2	IMPELLER (Brass) - 4 3/8" DIA. (See note 5)	816303-054	
2	IMPELLER (Brass) - 4" DIA. (See note 5)	816303-057	
23	IMPELLER KEY (WOODRUFF #2)	974507-100	
27	IMPELLER NUT	106076-000	
26	IMPELLER WASHER	927311-700	
15	MECHANICAL SEAL ASSY. (Viton) (4)	816706-023	
7	RESILIENT MTD. MOT. ASSY. - 1PH/1/4HP/115V	816141-001	
7	RIGID MOUNT. MOT. ASSY. - 3PH/1/4HP/208/230/460V(6)	830781-083	
7	RESILIENT MTD. MOT. ASSY. - 1PH/1/3HP/115V	816141-002	
7	RIGID MOUNT. MOT. ASSY. - 3PH/1/3HP/208/230/460V(6)	830590-083	
7	RESILIENT MTD. MOT. ASSY. - 1PH/1/2HP/115/230V	811757-001	
7	RIGID MOUNT. MOT. ASSY. - 3PH/1/2HP/208/230/460V(6)	831011-083	
7	RIGID MOUNT. MOT. ASSY. - 3PH/1/2HP/575V(6)	831011-083	
7	RESILIENT MTD. MOT. ASSY. - 1PH/3/4HP/115/230V	811757-002	
7	RIGID MOUNT. MOT. ASSY. - 3PH/3/4HP/208/230/460V(6)	831012-083	
7	RIGID MOUNT. MOT. ASSY. - 3PH/3/4HP/575V(6)	811757-006	
10	MOTOR CAPSCREWS - 3/8-16X3/4	911121-106	
17	O RING - MODULE	961131-036	
18	O RING - REAR BEARING	961131-024	
19	O RING - SHAFT	961131-013	
24	OIL SEAL	116975-000	
21	OIL WICK (BRIDGE)	116949-000	
20	OIL WICK (ROUND)	116948-000	
1	PUMP BODY	816338-041	
9	PUMP BODY CAPS. - 5/16-1/8x3/4	911123-108	
29	SEAL BEARING ASSEMBLY (1) & (4)	816032-000	
16	SHAFT AND BEARING MODULE (3) & (4)	816999-041	

- NOTES:** (1) Seal Bearing Assembly includes Bearing Bracket, Body Gasket, Standard 106076-000 Impeller Nut, Standard 927411-700 Impeller Washer, Module, Impeller Key, "Armitte" Seal Assembly, Ceramic Seal Seat, Buna "L" (retainer) Cup, and 5/8 Ounces of Oil.
- (2) Includes Face Plate and Buna "N" Oil Seal
- (3) Includes Front Sleeve Bearing, Shaft and Sleeve Assembly, two Oil Wicks, three "O" Rings, rear Sleeve Bearing Assembly, four Mounting Screws, Impeller Key, "Armitte" Seal Assembly, Ceramic Seal Seat, Buna "L" (retainer) Cup and 5/8 ounces of oil.
- (4) The 816706-021 Mechanical Seal on the Universal SBA and the Shaft & Bearing Module must be removed and replaced with a 816706-023 Viton High Temperature Mechanical Seal.
- (5) Impeller Part Number is for a full diameter Impeller. Always specify the Pump Serial Number and if possible the diameter of the impeller being replaced.
- (6) For TEFC or Explosion Proof Motors, contact the factory.

CIRCULATOR PARTS

MODEL NUMBER 1050 2B - SIZE 5 Serial No. 6208 & Later STANDARD AND BRONZE FITTED CONSTRUCTION

ITEM NO.	DESCRIPTION	PART NUMBER	ARMSTRONG BAR CODE
28	BODY GASKET	106158-000	
12	BRACKET HOUSING (2)	816966-111	
8	COUPLER ASSEMBLY (Flexible) 1 PHASE 1/2X1/2	807436-000	
8	COUPLER ASSEMBLY (Flexible) 3 PHASE 1/2X5/8	806137-000	
0	COUPLER INSERT	875000-800	
22	FACEPLATE	174003-071	
3	FLANGE - 2" NPT - CAST IRON	106074-011	
5	FLANGE BOLTS - 1/2-13X2 1/4	911125-120	
4	FLANGE GASKET	105176-000	
11	FLANGE NUTS - 1/2-13	913125-118	
2	IMPELLER - 5 1/4" DIA. (See note 4)	816304-317	
2	IMPELLER - 4 3/4" DIA. (See note 4)	816304-321	
2	IMPELLER - 4" DIA. (See note 4)	816304-327	
23	IMPELLER KEY (WOODRUFF #2)	974507-100	
27	IMPELLER NUT	106076-000	
26	IMPELLER WASHER	927311-700	
15	MECHANICAL SEAL ASSEMBLY	816706-021	
7	RESILIENT MTD. MOT. ASSY. - 1PH/1/3HP/115/230V	816141-002	
7	RIGID MOUNT. MOT. ASSY. - 3PH/1/3HP/208/230/460V (5)	830590-083	
7	RESILIENT MTD. MOT. ASSY. - 1PH/1/2HP/115/230V	811757-001	
7	RIGID MOUNT. MOT. ASSY. - 3PH/1/2HP/208/230/460V(5)	831011-083	
7	RIGID MOUNT. MOT. ASSY. - 3PH/1/2HP/575V(5)	831011-083	
7	RESILIENT MTD. MOT. ASSY. - 1PH/3/4HP/115/230V	811757-002	
7	RIGID MOUNT. MOT. ASSY. - 3PH/3/4HP/208/230/460V(5)	831012-083	
7	RIGID MOUNT. MOT. ASSY. - 3PH/3/4HP/575V(5)	811757-006	
7	RESILIENT MTD. MOT. ASSY. - 1PH/1HP/115/230V	811757-007	
7	RIGID MOUNT. MOT. ASSY. - 1PH/1HP/115/230V(5)	816676-062	
7	RIGID MOUNT. MOT. ASSY. - 3PH/1HP/208/230/460V(5)	816676-069	
7	RIGID MOUNT. MOT. ASSY. - 3PH/1HP/575V(5)	811757-009	
10	MOTOR CAPSCREWS - 3/8-16X3/4	911121-106	
17	O RING - MODULE	961131-036	
18	O RING - REAR BEARING	961131-024	
19	O RING - SHAFT	961131-013	
24	OIL SEAL	116975-000	
21	OIL WICK (BRIDGE)	116949-000	
20	OIL WICK (ROUND)	116948-000	
1	PUMP BODY	816338-011	
9	PUMP BODY CAPS. - 5/16-1/8x3/4	911123-108	
29	SEAL BEARING ASSEMBLY (1)	816032-000	
16	SHAFT AND BEARING MODULE (3)	816999-041	

- NOTES:** (1) Seal Bearing Assembly includes Bearing Bracket, Body Gasket, Standard 106076-000 Impeller Nut, Standard 927411-700 Impeller Washer, Module, Impeller Key, "Armité" Seal Assembly, Ceramic Seal Seat, Buna "L" (retainer) Cup, and 5/8 Ounces of Oil.
- (2) Includes Face Plate and Buna "N" Oil Seal
- (3) Includes Front Sleeve Bearing, Shaft and Sleeve Assembly, two Oil Wicks, three "O" Rings, rear Sleeve Bearing Assembly, four Mounting Screws, Impeller Key, "Armité" Seal Assembly, Ceramic Seal Seat, Buna "L" (retainer) Cup and 5/8 ounces of oil.
- (4) Impeller Part Numbers are for stock diameter Impellers. For Impeller Diameters not listed, please contact the factory.
- (5) For TEFC or Explosion Proof Motors, please contact the factory.

CIRCULATOR PARTS

MODEL NUMBER 1050 2B - SIZE 5 Serial No. 6208 & Later ALL BRONZE CONSTRUCTION

ITEM NO.	DESCRIPTION	PART NUMBER	ARMSTRONG BAR CODE
28	BODY GASKET	106158-000	
12	BRACKET HOUSING (2)	816966-111	
8	COUPLER ASSEMBLY (Flexible) 1 PHASE 1/2X1/2	807436-000	
8	COUPLER ASSEMBLY (Flexible) 3 PHASE 1/2X5/8	806137-000	
0	COUPLER INSERT	875000-800	
22	FACEPLATE	174003-071	
3	FLANGE - 2" NPT - BRONZE	106074-041	
5	FLANGE BOLTS - 1/2-13X2 1/4	911125-120	
4	FLANGE GASKET	105176-000	
11	FLANGE NUTS - 1/2-13	913125-118	
2	IMPELLER - 5 1/4" DIA. (See note 4)	816304-317	
2	IMPELLER - 4 3/4" DIA. (See note 4)	816304-321	
2	IMPELLER - 4" DIA. (See note 4)	816304-327	
23	IMPELLER KEY (WOODRUFF #2)	974507-100	
27	IMPELLER NUT	106076-000	
26	IMPELLER WASHER	927311-700	
15	MECHANICAL SEAL ASSEMBLY	816706-021	
7	RESILIENT MTD. MOT. ASSY. - 1PH/1/3HP/115/230V	816141-002	
7	RIGID MOUNT. MOT. ASSY. - 3PH/1/3HP/208/230/460V(6)	830590-083	
7	RESILIENT MTD. MOT. ASSY. - 1PH/1/2HP/115/230V	811757-001	
7	RIGID MOUNT. MOT. ASSY. - 3PH/1/2HP/208/230/460V(6)	831011-083	
7	RIGID MOUNT. MOT. ASSY. - 3PH/1/2HP/575V(6)	831011-083	
7	RESILIENT MTD. MOT. ASSY. - 1PH/3/4HP/115/230V	811757-002	
7	RIGID MOUNT. MOT. ASSY. - 3PH/3/4HP/208/230/460V(6)	831012-083	
7	RIGID MOUNT. MOT. ASSY. - 3PH/3/4HP/575V(6)	811757-006	
7	RESILIENT MTD. MOT. ASSY. - 1PH/1HP/115/230V	811757-007	
7	RIGID MOUNT. MOT. ASSY. - 1PH/1HP/115/230V(6)	816676-062	
7	RIGID MOUNT. MOT. ASSY. - 3PH/1HP/208/230/460V(6)	816676-069	
7	RIGID MOUNT. MOT. ASSY. - 3PH/1HP/575V(6)	811757-009	
10	MOTOR CAPSCREWS - 3/8-16X3/4	911121-106	
17	O RING - MODULE	961131-036	
18	O RING - REAR BEARING	961131-024	
19	O RING - SHAFT	961131-013	
24	OIL SEAL	116975-000	
21	OIL WICK (BRIDGE)	116949-000	
20	OIL WICK (ROUND)	116948-000	
1	PUMP BODY	816338-041	
9	PUMP BODY CAPS. - 5/16-1/8x3/4	911123-108	
29	SEAL BEARING ASSEMBLY (1)	816032-000	
16	SHAFT AND BEARING MODULE (3)	816999-041	

- NOTES:** (1) Seal Bearing Assembly includes Bearing Bracket, Body Gasket, Standard 106076-000 Impeller Nut, Standard 927411-700 Impeller Washer, Module, Impeller Key, "Armité" Seal Assembly, Ceramic Seal Seat, Buna "L" (retainer) Cup, and 5/8 Ounces of Oil.
- (2) Includes Face Plate and Buna "N" Oil Seal
- (3) Includes Front Sleeve Bearing, Shaft and Sleeve Assembly, two Oil Wicks, three "O" Rings, rear Sleeve Bearing Assembly, four Mounting Screws, Impeller Key, "Armité" Seal Assembly, Ceramic Seal Seat, Buna "L" (retainer) Cup and 5/8 ounces of oil.
- (4) Impeller Part Numbers are for stock diameter Impellers. For Impeller Diameters not listed, please contact the factory.
- (5) For TEFC or Explosion Proof Motors, contact the factory.

CIRCULATOR PARTS

MODEL NUMBER 1050 2B - SIZE 5 Serial No. 6208 & Later HIGH TEMP. STANDARD CONSTRUCTION (225 - 275 DEG. F)

ITEM NO.	DESCRIPTION	PART NUMBER	ARMSTRONG BAR CODE
28	BODY GASKET	106158-000	
12	BRACKET HOUSING (2)	816966-111	
8	COUPLER ASSEMBLY (Flexible) 1 PHASE 1/2X1/2	807436-000	
8	COUPLER ASSEMBLY (Flexible) 3 PHASE 1/2X5/8	806137-000	
0	COUPLER INSERT	875000-800	
22	FACEPLATE	174003-071	
3	FLANGE - 2" NPT - CAST IRON	106074-011	
5	FLANGE BOLTS - 1/2-13X2 1/4	911125-120	
4	FLANGE GASKET	105176-000	
11	FLANGE NUTS - 1/2-13	913125-118	
2	IMPELLER (Steel) - 5 1/4" DIA. (See note 5)	816304-017	
2	IMPELLER (Steel) - 4 3/4" DIA. (See note 5)	816304-021	
2	IMPELLER (Steel) - 4" DIA. (See note 5)	816304-027	
23	IMPELLER KEY (WOODRUFF #2)	974507-100	
27	IMPELLER NUT	106076-000	
26	IMPELLER WASHER	927311-700	
15	MECHANICAL SEAL ASSY. (Viton) (4)	816706-023	
7	RESILIENT MTD. MOT. ASSY. - 1PH/1/3HP/115/230V	816141-002	
7	RIGID MOUNT. MOT. ASSY. - 3PH/1/3HP/208/230/460V(6)	830590-083	
7	RESILIENT MTD. MOT. ASSY. - 1PH/1/2HP/115/230V	811757-001	
7	RIGID MOUNT. MOT. ASSY. - 3PH/1/2HP/208/230/460V(6)	831011-083	
7	RIGID MOUNT. MOT. ASSY. - 3PH/1/2HP/575V(6)	831011-083	
7	RESILIENT MTD. MOT. ASSY. - 1PH/3/4HP/115/230V	811757-002	
7	RIGID MOUNT. MOT. ASSY. - 3PH/3/4HP/208/230/460V(6)	831012-083	
7	RIGID MOUNT. MOT. ASSY. - 3PH/3/4HP/575V(6)	811757-006	
7	RESILIENT MTD. MOT. ASSY. - 1PH/1HP/115/230V	811757-007	
7	RIGID MOUNT. MOT. ASSY. - 1PH/1HP/115/230V(6)	816676-062	
7	RIGID MOUNT. MOT. ASSY. - 3PH/1HP/208/230/460V(6)	816676-069	
7	RIGID MOUNT. MOT. ASSY. - 3PH/1HP/575V(6)	811757-009	
10	MOTOR CAPSCREWS - 3/8-16X3/4	911121-106	
17	O RING - MODULE	961131-036	
18	O RING - REAR BEARING	961131-024	
19	O RING - SHAFT	961131-013	
24	OIL SEAL	116975-000	
21	OIL WICK (BRIDGE)	116949-000	
20	OIL WICK (ROUND)	116948-000	
1	PUMP BODY	816338-011	
9	PUMP BODY CAPS. - 5/16-1/8x3/4	911123-108	
29	SEAL BEARING ASSEMBLY (1) & (4)	816032-000	
16	SHAFT AND BEARING MODULE (3) & (4)	816999-041	

- NOTES:** (1) Seal Bearing Assembly includes Bearing Bracket, Body Gasket, Standard 106076-000 Impeller Nut, Standard 927411-700 Impeller Washer, Module, Impeller Key, "Armitte" Seal Assembly, Ceramic Seal Seat, Buna "L" (retainer) Cup, and 5/8 Ounces of Oil.
- (2) Includes Face Plate and Buna "N" Oil Seal
- (3) Includes Front Sleeve Bearing, Shaft and Sleeve Assembly, two Oil Wicks, three "O" Rings, rear Sleeve Bearing Assembly, four Mounting Screws, Impeller Key, "Armitte" Seal Assembly, Ceramic Seal Seat, Buna "L" (retainer) Cup and 5/8 ounces of oil.
- (4) The 816706-021 Mechanical Seal on the Universal SBA and the Shaft & Bearing Module must be removed and replaced with a 816706-023 Viton High Temperature Mechanical Seal.
- (5) Impeller Part Number is for a full diameter Impeller. Always specify the Pump Serial Number and if possible the diameter of the impeller being replaced.
- (6) For TEFC or Explosion Proof Motors, contact the factory.

CIRCULATOR PARTS

MODEL NUMBER 1050 2B - SIZE 5 Serial No. 6208 & Later HIGH TEMP. BRONZE FITTED CONSTRUCTION (225 - 275 DEG. F)

ITEM NO.	DESCRIPTION	PART NUMBER	ARMSTRONG BAR CODE
28	BODY GASKET	106158-000	
12	BRACKET HOUSING (2)	816966-111	
8	COUPLER ASSEMBLY (Flexible) 1 PHASE 1/2X1/2	807436-000	
8	COUPLER ASSEMBLY (Flexible) 3 PHASE 1/2X5/8	806137-000	
0	COUPLER INSERT	875000-800	
22	FACEPLATE	174003-071	
3	FLANGE - 2" NPT - CAST IRON	106074-011	
5	FLANGE BOLTS - 1/2-13X2 1/4	911125-120	
4	FLANGE GASKET	105176-000	
11	FLANGE NUTS - 1/2-13	913125-118	
2	IMPELLER (Brass) - 5 1/4" DIA. (See note 5)	816304-047	
2	IMPELLER (Brass) - 4 3/4" DIA. (See note 5)	816304-051	
2	IMPELLER (Brass) - 4" DIA. (See note 5)	816304-057	
23	IMPELLER KEY (WOODRUFF #2)	974507-100	
27	IMPELLER NUT	106076-000	
26	IMPELLER WASHER	927311-700	
15	MECHANICAL SEAL ASSY. (Viton) (4)	816706-023	
7	RESILIENT MTD. MOT. ASSY. - 1PH/1/3HP/115/230V	816141-002	
7	RIGID MOUNT. MOT. ASSY. - 3PH/1/3HP/208/230/460V(6)	830590-083	
7	RESILIENT MTD. MOT. ASSY. - 1PH/1/2HP/115/230V	811757-001	
7	RIGID MOUNT. MOT. ASSY. - 3PH/1/2HP/208/230/460V(6)	831011-083	
7	RIGID MOUNT. MOT. ASSY. - 3PH/1/2HP/575V(6)	831011-083	
7	RESILIENT MTD. MOT. ASSY. - 1PH/3/4HP/115/230V	811757-002	
7	RIGID MOUNT. MOT. ASSY. - 3PH/3/4HP/208/230/460V(6)	831012-083	
7	RIGID MOUNT. MOT. ASSY. - 3PH/3/4HP/575V(6)	811757-006	
7	RESILIENT MTD. MOT. ASSY. - 1PH/1HP/115/230V	811757-007	
7	RIGID MOUNT. MOT. ASSY. - 1PH/1HP/115/230V(6)	816676-062	
7	RIGID MOUNT. MOT. ASSY. - 3PH/1HP/208/230/460V(6)	816676-069	
7	RIGID MOUNT. MOT. ASSY. - 3PH/1HP/575V(6)	811757-009	
10	MOTOR CAPSCREWS - 3/8-16X3/4	911121-106	
17	O RING - MODULE	961131-036	
18	O RING - REAR BEARING	961131-024	
19	O RING - SHAFT	961131-013	
24	OIL SEAL	116975-000	
21	OIL WICK (BRIDGE)	116949-000	
20	OIL WICK (ROUND)	116948-000	
1	PUMP BODY	816338-011	
9	PUMP BODY CAPS. - 5/16-1/8x3/4	911123-108	
29	SEAL BEARING ASSEMBLY (1) & (4)	816032-000	
16	SHAFT AND BEARING MODULE (3) & (4)	816999-041	

- NOTES:** (1) Seal Bearing Assembly includes Bearing Bracket, Body Gasket, Standard 106076-000 Impeller Nut, Standard 927411-700 Impeller Washer, Module, Impeller Key, "Armite" Seal Assembly, Ceramic Seal Seat, Buna "L" (retainer) Cup, and 5/8 Ounces of Oil.
(2) Includes Face Plate and Buna "N" Oil Seal
(3) Includes Front Sleeve Bearing, Shaft and Sleeve Assembly, two Oil Wicks, three "O" Rings, rear Sleeve Bearing Assembly, four Mounting Screws, Impeller Key, "Armite" Seal Assembly, Ceramic Seal Seat, Buna "L" (retainer) Cup and 5/8 ounces of oil.
(4) The 816706-021 Mechanical Seal on the Universal SBA and the Shaft & Bearing Module must be removed and replaced with a 816706-023 Viton High Temperature Mechanical Seal.
(5) Impeller Part Number is for a full diameter Impeller. Always specify the Pump Serial Number and if possible the diameter of the impeller being replaced.
(6) For TEFC or Explosion Proof Motors, contact the factory.

CIRCULATOR PARTS

MODEL NUMBER 1050 2B - SIZE 5 Serial No. 6208 & Later HIGH TEMP. ALL BRONZE CONSTRUCTION (225 - 275 DEG. F)

ITEM NO.	DESCRIPTION	PART NUMBER	ARMSTRONG BAR CODE
28	BODY GASKET	106158-000	
12	BRACKET HOUSING (2)	816966-111	
8	COUPLER ASSEMBLY (Flexible) 1 PHASE 1/2X1/2	807436-000	
8	COUPLER ASSEMBLY (Flexible) 3 PHASE 1/2X5/8	806137-000	
0	COUPLER INSERT	875000-800	
22	FACEPLATE	174003-071	
3	FLANGE - 2" NPT - BRONZE	106074-041	
5	FLANGE BOLTS - 1/2-13X2 1/4	911125-120	
4	FLANGE GASKET	105176-000	
11	FLANGE NUTS - 1/2-13	913125-118	
2	IMPELLER (Brass) - 5 1/4" DIA. (See note 5)	816304-047	
2	IMPELLER (Brass) - 4 3/4" DIA. (See note 5)	816304-051	
2	IMPELLER (Brass) - 4" DIA. (See note 5)	816304-057	
23	IMPELLER KEY (WOODRUFF #2)	974507-100	
27	IMPELLER NUT	106076-000	
26	IMPELLER WASHER	927311-700	
15	MECHANICAL SEAL ASSY. (Viton) (4)	816706-023	
7	RESILIENT MTD. MOT. ASSY. - 1PH/1/3HP/115/230V	816141-002	
7	RIGID MOUNT. MOT. ASSY. - 3PH/1/3HP/208/230/460V(6)	830590-083	
7	RESILIENT MTD. MOT. ASSY. - 1PH/1/2HP/115/230V	811757-001	
7	RIGID MOUNT. MOT. ASSY. - 3PH/1/2HP/208/230/460V(6)	831011-083	
7	RIGID MOUNT. MOT. ASSY. - 3PH/1/2HP/575V(6)	831011-083	
7	RESILIENT MTD. MOT. ASSY. - 1PH/3/4HP/115/230V	811757-002	
7	RIGID MOUNT. MOT. ASSY. - 3PH/3/4HP/208/230/460V(6)	831012-083	
7	RIGID MOUNT. MOT. ASSY. - 3PH/3/4HP/575V(6)	811757-006	
7	RESILIENT MTD. MOT. ASSY. - 1PH/1HP/115/230V	811757-007	
7	RIGID MOUNT. MOT. ASSY. - 1PH/1HP/115/230V(6)	816676-062	
7	RIGID MOUNT. MOT. ASSY. - 3PH/1HP/208/230/460V(6)	816676-069	
7	RIGID MOUNT. MOT. ASSY. - 3PH/1HP/575V(6)	811757-009	
10	MOTOR CAPSCREWS - 3/8-16X3/4	911121-106	
17	O RING - MODULE	961131-036	
18	O RING - REAR BEARING	961131-024	
19	O RING - SHAFT	961131-013	
24	OIL SEAL	116975-000	
21	OIL WICK (BRIDGE)	116949-000	
20	OIL WICK (ROUND)	116948-000	
1	PUMP BODY	816338-041	
9	PUMP BODY CAPS. - 5/16-1/8x3/4	911123-108	
29	SEAL BEARING ASSEMBLY (1) & (4)	816032-000	
16	SHAFT AND BEARING MODULE (3) & (4)	816999-041	

- NOTES:**
- (1) Seal Bearing Assembly includes Bearing Bracket, Body Gasket, Standard 106076-000 Impeller Nut, Standard 927411-700 Impeller Washer, Module, Impeller Key, "Armite" Seal Assembly, Ceramic Seal Seat, Buna "L" (retainer) Cup, and 5/8 Ounces of Oil.
 - (2) Includes Face Plate and Buna "N" Oil Seal
 - (3) Includes Front Sleeve Bearing, Shaft and Sleeve Assembly, two Oil Wicks, three "O" Rings, rear Sleeve Bearing Assembly, four Mounting Screws, Impeller Key, "Armite" Seal Assembly, Ceramic Seal Seat, Buna "L" (retainer) Cup and 5/8 ounces of oil.
 - (4) The 816706-021 Mechanical Seal on the Universal SBA and the Shaft & Bearing Module must be removed and replaced with a 816706-023 Viton High Temperature Mechanical Seal.
 - (5) Impeller Part Number is for a full diameter Impeller. Always specify the Pump Serial Number and if possible the diameter of the impeller being replaced.
 - (6) For TEFC or Explosion Proof Motors, contact the factory.

CIRCULATOR PARTS

MODEL NUMBER S69 - SIZE 6 Serial No. 6505 & Later STANDARD BRONZE FITTED CONSTRUCTION			
ITEM NO.	DESCRIPTION	PART NUMBER	ARMSTRONG BAR CODE
35	BEARING ASSEMBLY (1)	816366-041	
35	BEARING ASSEMBLY KIT C/W Seal Kit & Cover Plate (2)	816861-041	
10	BEARING BRACKET	816342-011	
4	BEARING CAP ASSEMBLY (3)	874112-000	
3	BEARING CAP CAPSCREWS 1/4-20X5/8	911117-105	
29	BODY	816339-011	
21	BODY CAPS. - 3/8-16X7/8	911121-107	
28	BODY GASKET	106592-000	
2	COUPLER ASSEMBLY (Flexible) 5/8X5/8	816665-000	
15	COUPLER GUARD	116114-000	
0	COUPLER INSERT	875000-801	
7	COUPLER KEY (Woodruff #9)	974515-100	
20	COVERPLATE (Cast Iron)	816346-011	
18	COVERPLATE CAPSCREWS 5/16-18X3/4	911119-106	
31	FLANGE - 3" NPT - (Cast Iron)	106074-011	
32	FLANGE BOLTS - 5/8-11X2 1/2	911129-120	
30	FLANGE GASKET	105201-000	
-	FLANGE NUTS - 5/8-11	913129-100	
25	IMPELLER (Brass) 5 7/8"	816308-042	
8	IMPELLER KEY (WOODRUFF #3)	974508-100	
27	IMPELLER NUT 7/16-20NF (Bronze)	116406-000	
26	IMPELLER WASHER	927412-700	
15	MECH. SEAL ASSY. (Brass Buna)	816707-001	
15	MECH. SEAL ASSY. (Brass Viton High Temp. 225F-275F)	816707-003	
14	OIL LEVEL WINDOW	116904-001	
9	OIL SLINGER	116369-000	
12	OIL WELL COVER ASSEMBLY	116361-000	
11	OIL WELL COVER GASKET	116400-000	
-	OIL WICKS (3/8X1/2)	816565-000	
1	RESILIENT MTD. MOT. ASSY. - 1PH/1HP/115/230V (4)	811757-007	
17	RES. MTD. MTR. CAPSCREWS 3/8-16X5/8 (4 Req'd)	911121-106	
1	RIGID MOUNT. MOT. ASSY. - 1PH/1HP/115/230V (4)	816676-062	
1	RIGID MOUNT. MOT. ASSY. - 3PH/1HP/208/230/460V (4)	816676-069	
1	RIGID MOUNT. MOT. ASSY. - 3PH/1HP/575V (4)	811757-009	
17	RIGID MT. MTR. CAPSCREWS 3/8-16X7/8 (4 Req'd)	911121-107	
6	SHAFT & SLEEVE ASSEMBLY	816354-041	
6	SHAFT & SLEEVE ASSY. (S/S Sleeve)	816354-071	
19	WATER SLINGER	116368-000	

- NOTES:** (1) Bearing Assembly does not include Coverplate, Mechanical Seal Assembly, Ceramic Seat or Retainer Cup.
(2) Bearing Assembly Kit includes B/F Coverplate, Mechanical Seal Assembly, Ceramic Seat and Retainer Cup.
(3) 874112-000 Brg/Cap assy.Kit includes Brg/Cap Assy., "O" Ring, Oil Seal & Oil Wick.
(4) For TEFC or Explosion Proof Motors, contact the factory.

CIRCULATOR PARTS

MODEL NUMBER S69 - SIZE 6 Serial No. 6505 & Later ALL BRONZE CONSTRUCTION

ITEM NO.	DESCRIPTION	PART NUMBER	ARMSTRONG BAR CODE
35	BEARING ASSEMBLY (1)	816366-041	
35	BEARING ASSEMBLY KIT C/W Seal Kit & Cover Plate (2)	816861-041	
10	BEARING BRACKET	816342-011	
4	BEARING CAP ASSEMBLY (3)	874112-000	
3	BEARING CAP CAPSCREWS 1/4-20X5/8	911117-105	
29	BODY	816339-041	
21	BODY CAPS. - 3/8-16X7/8	911121-107	
28	BODY GASKET	106592-000	
2	COUPLER ASSEMBLY (Flexible) 5/8X5/8	816665-000	
15	COUPLER GUARD	116114-000	
0	COUPLER INSERT	875000-801	
7	COUPLER KEY (Woodruff #9)	974515-100	
20	COVERPLATE (Bronze)	816346-041	
18	COVERPLATE CAPSCREWS 5/16-18X3/4	911119-106	
31	FLANGE - 3" NPT - (Bronze)	106074-041	
32	FLANGE BOLTS - 5/8-11X2 1/2	911129-120	
30	FLANGE GASKET	105201-000	
-	FLANGE NUTS - 5/8-11	913129-100	
25	IMPELLER (Brass) 5 7/8"	816308-042	
8	IMPELLER KEY (WOODRUFF #3)	974508-100	
27	IMPELLER NUT 7/16-20NF (Bronze)	116406-000	
26	IMPELLER WASHER	927412-700	
15	MECH. SEAL ASSY. (Brass Buna)	816707-001	
15	MECH. SEAL ASSY. (Brass Viton High Temp. 225F-275F)	816707-003	
14	OIL LEVEL WINDOW	116904-001	
9	OIL SLINGER	116369-000	
12	OIL WELL COVER ASSEMBLY	116361-000	
11	OIL WELL COVER GASKET	116400-000	
-	OIL WICKS (3/8X1/2)	816565-000	
1	RESILIENT MTD. MOT. ASSY. - 1PH/1HP/115/230V (4)	811757-007	
17	RES. MTD. MTR. CAPSCREWS 3/8-16X5/8 (4 Req'd)	911121-106	
1	RIGID MOUNT. MOT. ASSY. - 1PH/1HP/115/230V (4)	816676-062	
1	RIGID MOUNT. MOT. ASSY. - 3PH/1HP/208/230/460V (4)	816676-069	
1	RIGID MOUNT. MOT. ASSY. - 3PH/1HP/575V (4)	811757-009	
17	RIGID MT. MTR. CAPSCREWS 3/8-16X7/8 (4 Req'd)	911121-107	
6	SHAFT & SLEEVE ASSEMBLY	816354-041	
6	SHAFT & SLEEVE ASSY. (S/S Sleeve)	816354-071	
19	WATER SLINGER	116368-000	

- NOTES:** (1) Bearing Assembly does not include Coverplate, Mechanical Seal Assembly, Ceramic Seat or Retainer Cup.
(2) Bearing Assembly Kit includes B/F Coverplate, Mechanical Seal Assembly, Ceramic Seat and Retainer Cup.
(3) 874112-000 Brg/Cap assy.Kit includes Brg/Cap Assy., "O" Ring, Oil Seal & Oil Wick.
(4) For TEFC or Explosion Proof Motors, contact the factory.

CIRCULATOR PARTS

MODEL NUMBER S69 - SIZE 6 Serial No. 6505 & Later ALL IRON CONSTRUCTION

ITEM NO.	DESCRIPTION	PART NUMBER	ARMSTRONG BAR CODE
35	BEARING ASSEMBLY (1)	816366-071	
35	BEARING ASSEMBLY KIT C/W Seal Kit & Cover Plate (2)	816861-071	
10	BEARING BRACKET	816342-011	
4	BEARING CAP ASSEMBLY (3)	874112-000	
3	BEARING CAP CAPSCREWS 1/4-20X5/8	911117-105	
29	BODY	816339-011	
21	BODY CAPS. - 3/8-16X7/8	911121-107	
28	BODY GASKET	106592-000	
2	COUPLER ASSEMBLY (Flexible) 5/8X5/8	816665-000	
15	COUPLER GUARD	116114-000	
0	COUPLER INSERT	875000-801	
7	COUPLER KEY (Woodruff #9)	974515-100	
20	COVERPLATE (Bronze)	816346-041	
18	COVERPLATE CAPSCREWS 5/16-18X3/4	911119-106	
31	FLANGE - 3" NPT - (Cast Iron)	106074-011	
32	FLANGE BOLTS - 5/8-11X2 1/2	911129-120	
30	FLANGE GASKET	105201-000	
-	FLANGE NUTS - 5/8-11	913129-100	
25	IMPELLER (Steel) 5 7/8"	816308-012	
8	IMPELLER KEY (WOODRUFF #3)	974508-100	
27	IMPELLER NUT 7/16-20NF (Bronze)	913173-100	
26	IMPELLER WASHER	927412-700	
15	MECH. SEAL ASSY. (Steel Buna)	816707-002	
15	MECH. SEAL ASSY. (Steel Viton High Temp. 225F-275F)	816707-004	
14	OIL LEVEL WINDOW	116904-001	
9	OIL SLINGER	116369-000	
12	OIL WELL COVER ASSEMBLY	116361-000	
11	OIL WELL COVER GASKET	116400-000	
-	OIL WICKS (3/8X1/2)	816565-000	
1	RESILIENT MTD. MOT. ASSY. - 1PH/1/2HP/115/230V	811757-001	
17	RES. MTD. MTR. CAPSCREWS 3/8-16X5/8 (4 Req'd)	911121-106	
1	RIGID MOUNT. MOT. ASSY. - 1PH /1/2HP/115/230V (4)	831009-062	
1	RIGID MOUNT. MOT. ASSY. - 3PH/1/2HP/208/230/460V (4)	831011-083	
1	RIGID MOUNT. MOT. ASSY. - 3PH/1/2HP/575V (4)	811757-004	
17	RIGID MT. MTR. CAPSCREWS 3/8-16X7/8 (4 Req'd)	911121-107	
6	SHAFT & SLEEVE ASSEMBLY (S/S Sleeve)	816354-071	
19	WATER SLINGER	116368-000	

NOTES: (1) Bearing Assembly does not include Coverplate, Mechanical Seal Assembly, Ceramic Seat or Retainer Cup.
(2) Bearing Assembly Kit includes B/F Coverplate, Mechanical Seal Assembly, Ceramic Seat and Retainer Cup.
(3) 874112-000 Brg/Cap assy.Kit includes Brg/Cap Assy., "O" Ring, Oil Seal & Oil Wick.
(4) For TEFC or Explosion Proof Motors, contact the factory.

CIRCULATOR PARTS

MODEL NUMBER H63 - SIZE 6 Serial No. 6505 & Later			
STANDARD BRONZE FITTED CONSTRUCTION			
ITEM NO.	DESCRIPTION	PART NUMBER	ARMSTRONG BAR CODE
35	BEARING ASSEMBLY (1)	816366-041	
35	BEARING ASSEMBLY KIT C/W Seal Kit & Cover Plate (2)	816861-041	
10	BEARING BRACKET	816342-011	
4	BEARING CAP ASSEMBLY (3)	874112-000	
3	BEARING CAP CAPSCREWS 1/4-20X5/8	911117-105	
29	BODY	816397-011	
21	BODY CAPS. - 3/8-16X7/8	911121-107	
28	BODY GASKET	106592-000	
2	COUPLER ASSEMBLY (Flexible) 5/8X5/8	816665-000	
15	COUPLER GUARD	116114-000	
0	COUPLER INSERT	875000-801	
7	COUPLER KEY (Woodruff #9)	974515-100	
20	COVERPLATE (Cast Iron)	816346-011	
18	COVERPLATE CAPSCREWS 5/16-18X3/4	911119-106	
31	FLANGE -1 1/2" NPT - (Cast Iron)	104301-011	
32	FLANGE BOLTS - 7/16-14X2	911123-116	
30	FLANGE GASKET	104034-000	
-	FLANGE NUTS - 7/16-14	913129-100	
25	IMPELLER (Brass) 5 3/4"	874058-051	
8	IMPELLER KEY (WOODRUFF #3)	974508-100	
27	IMPELLER NUT 7/16-20NF (Bronze)	116406-000	
26	IMPELLER WASHER	927412-700	
15	MECH. SEAL ASSY. (Brass Buna)	816707-001	
15	MECH. SEAL ASSY. (Brass Viton High Temp. 225F-275F)	816707-003	
14	OIL LEVEL WINDOW	116904-001	
9	OIL SLINGER	116369-000	
12	OIL WELL COVER ASSEMBLY	116361-000	
11	OIL WELL COVER GASKET	116400-000	
-	OIL WICKS (3/8X1/2)	816565-000	
1	RESILIENT MTD. MOT. ASSY. - 1PH/1/2HP/115/230V	811757-001	
17	RES. MTD. MTR. CAPSCREWS 3/8-16X5/8 (4 Req'd)	911121-106	
1	RIGID MOUNT. MOT. ASSY. - 1PH /1/2HP/115/230V (4)	831009-062	
1	RIGID MOUNT. MOT. ASSY. - 3PH/1/2HP/208/230/460V (4)	831011-083	
1	RIGID MOUNT. MOT. ASSY. - 3PH/1/2HP/575V (4)	811757-004	
17	RIGID MT. MTR. CAPSCREWS 3/8-16X7/8 (4 Req'd)	911121-107	
6	SHAFT & SLEEVE ASSEMBLY	816354-041	
6	SHAFT & SLEEVE ASSY. (S/S Sleeve)	816354-071	
19	WATER SLINGER	116368-000	

- NOTES:** (1) Bearing Assembly does not include Coverplate, Mechanical Seal Assembly, Ceramic Seat or Retainer Cup.
(2) Bearing Assembly Kit includes B/F Coverplate, Mechanical Seal Assembly, Ceramic Seat and Retainer Cup.
(3) 874112-000 Brg/Cap assy.Kit includes Brg/Cap Assy., "O" Ring, Oil Seal & Oil Wick.
(4) For TEFC or Explosion Proof Motors, contact the factory.

CIRCULATOR PARTS

MODEL NUMBER H63 - SIZE 6 Serial No. 6505 & Later ALL BRONZE CONSTRUCTION

ITEM NO.	DESCRIPTION	PART NUMBER	ARMSTRONG BAR CODE
35	BEARING ASSEMBLY (1)	816366-041	
35	BEARING ASSEMBLY KIT C/W Seal Kit & Cover Plate (2)	816861-041	
10	BEARING BRACKET	816342-011	
4	BEARING CAP ASSEMBLY (3)	874112-000	
3	BEARING CAP CAPSCREWS 1/4-20X5/8	911117-105	
29	BODY	816397-041	
21	BODY CAPS. - 3/8-16X7/8	911121-107	
28	BODY GASKET	106592-000	
2	COUPLER ASSEMBLY (Flexible) 5/8X5/8	816665-000	
15	COUPLER GUARD	116114-000	
0	COUPLER INSERT	875000-801	
7	COUPLER KEY (Woodruff #9)	974515-100	
20	COVERPLATE (Bronze)	816346-041	
18	COVERPLATE CAPSCREWS 5/16-18X3/4	911119-106	
31	FLANGE -1 1/2" NPT - (Bronze)	104301-041	
32	FLANGE BOLTS - 7/16-14X2	911123-116	
30	FLANGE GASKET	104034-000	
-	FLANGE NUTS - 7/16-14	913129-100	
25	IMPELLER (Brass) 5 3/4"	874058-051	
8	IMPELLER KEY (WOODRUFF #3)	974508-100	
27	IMPELLER NUT 7/16-20NF (Bronze)	116406-000	
26	IMPELLER WASHER	927412-700	
15	MECH. SEAL ASSY. (Brass Buna)	816707-001	
15	MECH. SEAL ASSY. (Brass Viton High Temp. 225F-275F)	816707-003	
14	OIL LEVEL WINDOW	116904-001	
9	OIL SLINGER	116369-000	
12	OIL WELL COVER ASSEMBLY	116361-000	
11	OIL WELL COVER GASKET	116400-000	
-	OIL WICKS (3/8X1/2)	816565-000	
1	RESILIENT MTD. MOT. ASSY. - 1PH/1/2HP/115/230V	811757-001	
17	RES. MTD. MTR. CAPSCREWS 3/8-16X5/8 (4 Req'd)	911121-106	
1	RIGID MOUNT. MOT. ASSY. - 1PH /1/2HP/115/230V (4)	831009-062	
1	RIGID MOUNT. MOT. ASSY. - 3PH/1/2HP/208/230/460V (4)	831011-083	
1	RIGID MOUNT. MOT. ASSY. - 3PH/1/2HP/575V (4)	811757-004	
17	RIGID MT. MTR. CAPSCREWS 3/8-16X7/8 (4 Req'd)	911121-107	
6	SHAFT & SLEEVE ASSEMBLY	816354-041	
6	SHAFT & SLEEVE ASSY. (S/S Sleeve)	816354-071	
19	WATER SLINGER	116368-000	

- NOTES:** (1) Bearing Assembly does not include Coverplate, Mechanical Seal Assembly, Ceramic Seat or Retainer Cup.
(2) Bearing Assembly Kit includes B/F Coverplate, Mechanical Seal Assembly, Ceramic Seat and Retainer Cup.
(3) 874112-000 Brg/Cap assy.Kit includes Brg/Cap Assy., "O" Ring, Oil Seal & Oil Wick.
(4) For TEFC or Explosion Proof Motors, contact the factory.

CIRCULATOR PARTS

MODEL NUMBER H63 - SIZE 6 Serial No. 6505 & Later ALL IRON CONSTRUCTION

ITEM NO.	DESCRIPTION	PART NUMBER	ARMSTRONG BAR CODE
35	BEARING ASSEMBLY (1)	816366-071	
35	BEARING ASSEMBLY KIT C/W Seal Kit & Cover Plate (2)	816861-071	
10	BEARING BRACKET	816342-011	
4	BEARING CAP ASSEMBLY (3)	874112-000	
3	BEARING CAP CAPSCREWS 1/4-20X5/8	911117-105	
29	BODY	816397-011	
21	BODY CAPS. - 3/8-16X7/8	911121-107	
28	BODY GASKET	106592-000	
2	COUPLER ASSEMBLY (Flexible) 5/8X5/8	816665-000	
15	COUPLER GUARD	116114-000	
0	COUPLER INSERT	875000-801	
7	COUPLER KEY (Woodruff #9)	974515-100	
20	COVERPLATE (Cast Iron)	816346-011	
18	COVERPLATE CAPSCREWS 5/16-18X3/4	911119-106	
31	FLANGE -1 1/2" NPT - (Cast Iron)	104301-011	
32	FLANGE BOLTS - 7/16-14X2	911123-116	
30	FLANGE GASKET	104034-000	
-	FLANGE NUTS - 7/16-14	913129-100	
25	IMPELLER (Steel) 5 3/4"	874058-021	
8	IMPELLER KEY (WOODRUFF #3)	974508-100	
27	IMPELLER NUT 7/16-20NF (Steel)	913173-100	
26	IMPELLER WASHER	927412-700	
15	MECH. SEAL ASSY. (Steel Buna)	816707-002	
15	MECH. SEAL ASSY. (Steel Viton High Temp. 225F-275F)	816707-004	
14	OIL LEVEL WINDOW	116904-001	
9	OIL SLINGER	116369-000	
12	OIL WELL COVER ASSEMBLY	116361-000	
11	OIL WELL COVER GASKET	116400-000	
-	OIL WICKS (3/8X1/2)	816565-000	
1	RESILIENT MTD. MOT. ASSY. - 1PH/1/2HP/115/230V	811757-001	
17	RES. MTD. MTR. CAPSCREWS 3/8-16X5/8 (4 Req'd)	911121-106	
1	RIGID MOUNT. MOT. ASSY. - 1PH /1/2HP/115/230V (4)	831009-062	
1	RIGID MOUNT. MOT. ASSY. - 3PH/1/2HP/208/230/460V (4)	831011-083	
1	RIGID MOUNT. MOT. ASSY. - 3PH/1/2HP/575V (4)	811757-004	
17	RIGID MT. MTR. CAPSCREWS 3/8-16X7/8 (4 Req'd)	911121-107	
6	SHAFT & SLEEVE ASSEMBLY (S/S Sleeve)	816354-071	
19	WATER SLINGER	116368-000	

- NOTES:** (1) Bearing Assembly does not include Coverplate, Mechanical Seal Assembly, Ceramic Seat or Retainer Cup.
(2) Bearing Assembly Kit includes B/F Coverplate, Mechanical Seal Assembly, Ceramic Seat and Retainer Cup.
(3) 874112-000 Brg/Cap assy.Kit includes Brg/Cap Assy., "O" Ring, Oil Seal & Oil Wick.
(4) For TEFC or Explosion Proof Motors, contact the factory.

CIRCULATOR PARTS

MODEL NUMBER H64 - SIZE 6 Serial No. 6505 & Later STANDARD BRONZE FITTED CONSTRUCTION			
ITEM NO.	DESCRIPTION	PART NUMBER	ARMSTRONG BAR CODE
35	BEARING ASSEMBLY (1)	816366-041	
35	BEARING ASSEMBLY KIT C/W Seal Kit & Cover Plate (2)	816861-041	
10	BEARING BRACKET	816342-011	
4	BEARING CAP ASSEMBLY (3)	874112-000	
3	BEARING CAP CAPSCREWS 1/4-20X5/8	911117-105	
29	BODY	816397-011	
21	BODY CAPS. - 3/8-16X7/8	911121-107	
28	BODY GASKET	106592-000	
2	COUPLER ASSEMBLY (Flexible) 5/8X5/8	816665-000	
15	COUPLER GUARD	116114-000	
0	COUPLER INSERT	875000-801	
7	COUPLER KEY (Woodruff #9)	974515-100	
20	COVERPLATE (Cast Iron)	816346-011	
18	COVERPLATE CAPSCREWS 5/16-18X3/4	911119-106	
31	FLANGE -1 1/2" NPT - (Cast Iron)	104301-011	
32	FLANGE BOLTS - 7/16-14X2	911123-116	
30	FLANGE GASKET	104034-000	
-	FLANGE NUTS - 7/16-14	913129-100	
25	IMPELLER (Brass) 6 1/2"	874058-045	
8	IMPELLER KEY (WOODRUFF #3)	974508-100	
27	IMPELLER NUT 7/16-20NF (Bronze)	116406-000	
26	IMPELLER WASHER	927412-700	
15	MECH. SEAL ASSY. (Brass Buna)	816707-001	
15	MECH. SEAL ASSY. (Brass Viton High Temp. 225F-275F)	816707-003	
14	OIL LEVEL WINDOW	116904-001	
9	OIL SLINGER	116369-000	
12	OIL WELL COVER ASSEMBLY	116361-000	
11	OIL WELL COVER GASKET	116400-000	
-	OIL WICKS (3/8X1/2)	816565-000	
1	RESILIENT MTD. MOT. ASSY. - 1PH/3/4HP/115/230V	811757-002	
17	RES. MTD. MTR. CAPSCREWS 3/8-16X5/8 (4 Req'd)	911121-106	
1	RIGID MOUNT. MOT. ASSY. - 1PH/3/4HP/115/230V (4)	831010-062	
1	RIGID MOUNT. MOT. ASSY. - 3PH/3/4HP/208/230/460V (4)	831012-083	
1	RIGID MOUNT. MOT. ASSY. - 3PH/3/4HP/575V (4)	811757-006	
17	RIGID MT. MTR. CAPSCREWS 3/8-16X7/8 (4 Req'd)	911121-107	
6	SHAFT & SLEEVE ASSEMBLY	816354-041	
6	SHAFT & SLEEVE ASSY. (S/S Sleeve)	816354-071	
19	WATER SLINGER	116368-000	

NOTES: (1) Bearing Assembly does not include Coverplate, Mechanical Seal Assembly, Ceramic Seat or Retainer Cup.
 (2) Bearing Assembly Kit includes B/F Coverplate, Mechanical Seal Assembly, Ceramic Seat and Retainer Cup.
 (3) 874112-000 Brg/Cap assy.Kit includes Brg/Cap Assy., "O" Ring, Oil Seal & Oil Wick.
 (4) For TEFC or Explosion Proof Motors, contact the factory.

CIRCULATOR PARTS

MODEL NUMBER H64 - SIZE 6 Serial No. 6505 & Later ALL BRONZE CONSTRUCTION

ITEM NO.	DESCRIPTION	PART NUMBER	ARMSTRONG BAR CODE
35	BEARING ASSEMBLY (1)	816366-041	
35	BEARING ASSEMBLY KIT C/W Seal Kit & Cover Plate (2)	816861-041	
10	BEARING BRACKET	816342-011	
4	BEARING CAP ASSEMBLY (3)	874112-000	
3	BEARING CAP CAPSCREWS 1/4-20X5/8	911117-105	
29	BODY	816397-041	
21	BODY CAPS. - 3/8-16X7/8	911121-107	
28	BODY GASKET	106592-000	
2	COUPLER ASSEMBLY (Flexible) 5/8X5/8	816665-000	
15	COUPLER GUARD	116114-000	
0	COUPLER INSERT	875000-801	
7	COUPLER KEY (Woodruff #9)	974515-100	
20	COVERPLATE (Bronze)	816346-041	
18	COVERPLATE CAPSCREWS 5/16-18X3/4	911119-106	
31	FLANGE -1 1/2" NPT - (Bronze)	104301-041	
32	FLANGE BOLTS - 7/16-14X2	911123-116	
30	FLANGE GASKET	104034-000	
-	FLANGE NUTS - 7/16-14	913129-100	
25	IMPELLER (Brass) 6 1/2"	874058-045	
8	IMPELLER KEY (WOODRUFF #3)	974508-100	
27	IMPELLER NUT 7/16-20NF (Bronze)	116406-000	
26	IMPELLER WASHER	927412-700	
15	MECH. SEAL ASSY. (Brass Buna)	816707-001	
15	MECH. SEAL ASSY. (Brass Viton High Temp. 225F-275F)	816707-003	
14	OIL LEVEL WINDOW	116904-001	
9	OIL SLINGER	116369-000	
12	OIL WELL COVER ASSEMBLY	116361-000	
11	OIL WELL COVER GASKET	116400-000	
-	OIL WICKS (3/8X1/2)	816565-000	
1	RESILIENT MTD. MOT. ASSY. - 1PH/3/4HP/115/230V	811757-002	
17	RES. MTD. MTR. CAPSCREWS 3/8-16X5/8 (4 Req'd)	911121-106	
1	RIGID MOUNT. MOT. ASSY. - 1PH/3/4HP/115/230V (4)	831010-062	
1	RIGID MOUNT. MOT. ASSY. - 3PH/3/4HP/208/230/460V (4)	831012-083	
1	RIGID MOUNT. MOT. ASSY. - 3PH/3/4HP/575V (4)	811757-006	
17	RIGID MT. MTR. CAPSCREWS 3/8-16X7/8 (4 Req'd)	911121-107	
6	SHAFT & SLEEVE ASSEMBLY	816354-041	
6	SHAFT & SLEEVE ASSY. (S/S Sleeve)	816354-071	
19	WATER SLINGER	116368-000	

- NOTES:** (1) Bearing Assembly does not include Coverplate, Mechanical Seal Assembly, Ceramic Seat or Retainer Cup.
 (2) Bearing Assembly Kit includes B/F Coverplate, Mechanical Seal Assembly, Ceramic Seat and Retainer Cup.
 (3) 874112-000 Brg/Cap assy.Kit includes Brg/Cap Assy., "O" Ring, Oil Seal & Oil Wick.
 (4) For TEFC or Explosion Proof Motors, contact the factory.

CIRCULATOR PARTS

MODEL NUMBER H64 - SIZE 6 Serial No. 6505 & Later ALL IRON CONSTRUCTION

ITEM NO.	DESCRIPTION	PART NUMBER	ARMSTRONG BAR CODE
35	BEARING ASSEMBLY (1)	816366-071	
35	BEARING ASSEMBLY KIT C/W Seal Kit & Cover Plate (2)	816861-071	
10	BEARING BRACKET	816342-011	
4	BEARING CAP ASSEMBLY (3)	874112-000	
3	BEARING CAP CAPSCREWS 1/4-20X5/8	911117-105	
29	BODY	816397-011	
21	BODY CAPS. - 3/8-16X7/8	911121-107	
28	BODY GASKET	106592-000	
2	COUPLER ASSEMBLY (Flexible) 5/8X5/8	816665-000	
15	COUPLER GUARD	116114-000	
0	COUPLER INSERT	875000-801	
7	COUPLER KEY (Woodruff #9)	974515-100	
20	COVERPLATE (Cast Iron)	816346-011	
18	COVERPLATE CAPSCREWS 5/16-18X3/4	911119-106	
31	FLANGE -1 1/2" NPT - (Cast Iron)	104301-011	
32	FLANGE BOLTS - 7/16-14X2	911123-116	
30	FLANGE GASKET	104034-000	
-	FLANGE NUTS - 7/16-14	913129-100	
25	IMPELLER (Steel) 6 1/2"	874058-015	
8	IMPELLER KEY (WOODRUFF #3)	974508-100	
27	IMPELLER NUT 7/16-20NF (Steel)	913173-100	
26	IMPELLER WASHER	927412-700	
15	MECH. SEAL ASSY. (Steel Buna)	816707-002	
15	MECH. SEAL ASSY. (Steel Viton High Temp. 225F-275F)	816707-004	
14	OIL LEVEL WINDOW	116904-001	
9	OIL SLINGER	116369-000	
12	OIL WELL COVER ASSEMBLY	116361-000	
11	OIL WELL COVER GASKET	116400-000	
-	OIL WICKS (3/8X1/2)	816565-000	
1	RESILIENT MTD. MOT. ASSY. - 1PH/3/4HP/115/230V	811757-002	
17	RES. MTD. MTR. CAPSCREWS 3/8-16X5/8 (4 Req'd)	911121-106	
1	RIGID MOUNT. MOT. ASSY. - 1PH/3/4HP/115/230V (4)	831010-062	
1	RIGID MOUNT. MOT. ASSY. - 3PH/3/4HP/208/230/460V (4)	831012-083	
1	RIGID MOUNT. MOT. ASSY. - 3PH/3/4HP/575V (4)	811757-006	
17	RIGID MT. MTR. CAPSCREWS 3/8-16X7/8 (4 Req'd)	911121-107	
6	SHAFT & SLEEVE ASSEMBLY (S/S Sleeve)	816354-071	
19	WATER SLINGER	116368-000	

- NOTES:** (1) Bearing Assembly does not include Coverplate, Mechanical Seal Assembly, Ceramic Seat or Retainer Cup.
(2) Bearing Assembly Kit includes B/F Coverplate, Mechanical Seal Assembly, Ceramic Seat and Retainer Cup.
(3) 874112-000 Brg/Cap assy.Kit includes Brg/Cap Assy., "O" Ring, Oil Seal & Oil Wick.
(4) For TEFC or Explosion Proof Motors, contact the factory.

CIRCULATOR PARTS

MODEL NUMBER H65 - SIZE 6 Serial No. 6505 & Later STANDARD BRONZE FITTED CONSTRUCTION

ITEM NO.	DESCRIPTION	PART NUMBER	ARMSTRONG BAR CODE
35	BEARING ASSEMBLY (1)	816366-041	
35	BEARING ASSEMBLY KIT C/W Seal Kit & Cover Plate (2)	816861-041	
10	BEARING BRACKET	816342-011	
4	BEARING CAP ASSEMBLY (3)	874112-000	
3	BEARING CAP CAPSCREWS 1/4-20X5/8	911117-105	
29	BODY	816397-011	
21	BODY CAPS. - 3/8-16X7/8	911121-107	
28	BODY GASKET	106592-000	
2	COUPLER ASSEMBLY (Flexible) 5/8X5/8	816665-000	
15	COUPLER GUARD	116114-000	
0	COUPLER INSERT	875000-801	
7	COUPLER KEY (Woodruff #9)	974515-100	
20	COVERPLATE (Cast Iron)	816346-011	
18	COVERPLATE CAPSCREWS 5/16-18X3/4	911119-106	
31	FLANGE -1 1/2" NPT - (Cast Iron)	104301-011	
32	FLANGE BOLTS - 7/16-14X2	911123-116	
30	FLANGE GASKET	104034-000	
-	FLANGE NUTS - 7/16-14	913129-100	
25	IMPELLER (Brass) 7"	874058-041	
8	IMPELLER KEY (WOODRUFF #3)	974508-100	
27	IMPELLER NUT 7/16-20NF (Bronze)	116406-000	
26	IMPELLER WASHER	927412-700	
15	MECH. SEAL ASSY. (Brass Buna)	816707-001	
15	MECH. SEAL ASSY. (Brass Viton High Temp. 225F-275F)	816707-003	
14	OIL LEVEL WINDOW	116904-001	
9	OIL SLINGER	116369-000	
12	OIL WELL COVER ASSEMBLY	116361-000	
11	OIL WELL COVER GASKET	116400-000	
-	OIL WICKS (3/8X1/2)	816565-000	
1	RESILIENT MTD. MOT. ASSY. - 1PH/1HP/115/230V	811757-007	
17	RES. MTD. MTR. CAPSCREWS 3/8-16X5/8 (4 Req'd)	911121-106	
1	RIGID MOUNT. MOT. ASSY. - 1PH/1HP/115/230V (6)	816676-062	
1	RIGID MOUNT. MOT. ASSY. - 3PH/1HP/208/230/460V (6)	816676-069	
1	RIGID MOUNT. MOT. ASSY. - 3PH/1HP/575V (6)	811757-009	
17	RIGID MT. MTR. CAPSCREWS 3/8-16X7/8 (4 Req'd)	911121-107	
6	SHAFT & SLEEVE ASSEMBLY	816354-041	
6	SHAFT & SLEEVE ASSY. (S/S Sleeve)	816354-071	
19	WATER SLINGER	116368-000	

- NOTES:** (1) Bearing Assembly does not include Coverplate, Mechanical Seal Assembly, Ceramic Seat or Retainer Cup.
(2) Bearing Assembly Kit includes B/F Coverplate, Mechanical Seal Assembly, Ceramic Seat and Retainer Cup.
(3) 874112-000 Brg/Cap assy.Kit includes Brg/Cap Assy., "O" Ring, Oil Seal & Oil Wick.
(4) For TEFC or Explosion Proof Motors, contact the factory.

CIRCULATOR PARTS

MODEL NUMBER H65 - SIZE 6 Serial No. 6505 & Later ALL BRONZE CONSTRUCTION

ITEM NO.	DESCRIPTION	PART NUMBER	ARMSTRONG BAR CODE
35	BEARING ASSEMBLY (1)	816366-041	
35	BEARING ASSEMBLY KIT C/W Seal Kit & Cover Plate (2)	816861-041	
10	BEARING BRACKET	816342-011	
4	BEARING CAP ASSEMBLY (3)	874112-000	
3	BEARING CAP CAPSCREWS 1/4-20X5/8	911117-105	
29	BODY	816397-041	
21	BODY CAPS. - 3/8-16X7/8	911121-107	
28	BODY GASKET	106592-000	
2	COUPLER ASSEMBLY (Flexible) 5/8X5/8	816665-000	
15	COUPLER GUARD	116114-000	
0	COUPLER INSERT	875000-801	
7	COUPLER KEY (Woodruff #9)	974515-100	
20	COVERPLATE (Bronze)	816346-041	
18	COVERPLATE CAPSCREWS 5/16-18X3/4	911119-106	
31	FLANGE -1 1/2" NPT - (Bronze)	104301-041	
32	FLANGE BOLTS - 7/16-14X2	911123-116	
30	FLANGE GASKET	104034-000	
-	FLANGE NUTS - 7/16-14	913129-100	
25	IMPELLER (Brass) 7"	874058-041	
8	IMPELLER KEY (WOODRUFF #3)	974508-100	
27	IMPELLER NUT 7/16-20NF (Bronze)	116406-000	
26	IMPELLER WASHER	927412-700	
15	MECH. SEAL ASSY. (Brass Buna)	816707-001	
15	MECH. SEAL ASSY. (Brass Viton High Temp. 225F-275F)	816707-003	
14	OIL LEVEL WINDOW	116904-001	
9	OIL SLINGER	116369-000	
12	OIL WELL COVER ASSEMBLY	116361-000	
11	OIL WELL COVER GASKET	116400-000	
-	OIL WICKS (3/8X1/2)	816565-000	
1	RESILIENT MTD. MOT. ASSY. - 1PH/1HP/115/230V	811757-007	
17	RES. MTD. MTR. CAPSCREWS 3/8-16X5/8 (4 Req'd)	911121-106	
1	RIGID MOUNT. MOT. ASSY. - 1PH/1HP/115/230V (6)	816676-062	
1	RIGID MOUNT. MOT. ASSY. - 3PH/1HP/208/230/460V (6)	816676-069	
1	RIGID MOUNT. MOT. ASSY. - 3PH/1HP/575V (6)	811757-009	
17	RIGID MT. MTR. CAPSCREWS 3/8-16X7/8 (4 Req'd)	911121-107	
6	SHAFT & SLEEVE ASSEMBLY	816354-041	
6	SHAFT & SLEEVE ASSY. (S/S Sleeve)	816354-071	
19	WATER SLINGER	116368-000	

- NOTES:** (1) Bearing Assembly does not include Coverplate, Mechanical Seal Assembly, Ceramic Seat or Retainer Cup.
 (2) Bearing Assembly Kit includes B/F Coverplate, Mechanical Seal Assembly, Ceramic Seat and Retainer Cup.
 (3) 874112-000 Brg/Cap assy.Kit includes Brg/Cap Assy., "O" Ring, Oil Seal & Oil Wick.
 (4) For TEFC or Explosion Proof Motors, contact the factory.

CIRCULATOR PARTS

MODEL NUMBER H65 - SIZE 6 Serial No. 6505 & Later ALL IRON CONSTRUCTION

ITEM NO.	DESCRIPTION	PART NUMBER	ARMSTRONG BAR CODE
35	BEARING ASSEMBLY (1)	816366-071	
35	BEARING ASSEMBLY KIT C/W Seal Kit & Cover Plate (2)	816861-071	
10	BEARING BRACKET	816342-011	
4	BEARING CAP ASSEMBLY (3)	874112-000	
3	BEARING CAP CAPSCREWS 1/4-20X5/8	911117-105	
29	BODY	816397-011	
21	BODY CAPS. - 3/8-16X7/8	911121-107	
28	BODY GASKET	106592-000	
2	COUPLER ASSEMBLY (Flexible) 5/8X5/8	816665-000	
15	COUPLER GUARD	116114-000	
0	COUPLER INSERT	875000-801	
7	COUPLER KEY (Woodruff #9)	974515-100	
20	COVERPLATE (Cast Iron)	816346-011	
18	COVERPLATE CAPSCREWS 5/16-18X3/4	911119-106	
31	FLANGE -1 1/2" NPT - (Cast Iron)	104301-011	
32	FLANGE BOLTS - 7/16-14X2	911123-116	
30	FLANGE GASKET	104034-000	
-	FLANGE NUTS - 7/16-14	913129-100	
25	IMPELLER (Steel) 7"	874058-011	
8	IMPELLER KEY (WOODRUFF #3)	974508-100	
27	IMPELLER NUT 7/16-20NF (Steel)	913173-100	
26	IMPELLER WASHER	927412-700	
15	MECH. SEAL ASSY. (Steel Buna)	816707-002	
15	MECH. SEAL ASSY. (Steel Viton High Temp. 225F-275F)	816707-004	
14	OIL LEVEL WINDOW	116904-001	
9	OIL SLINGER	116369-000	
12	OIL WELL COVER ASSEMBLY	116361-000	
11	OIL WELL COVER GASKET	116400-000	
-	OIL WICKS (3/8X1/2)	816565-000	
1	RESILIENT MTD. MOT. ASSY. - 1PH/1HP/115/230V	811757-007	
17	RES. MTD. MTR. CAPSCREWS 3/8-16X5/8 (4 Req'd)	911121-106	
1	RIGID MOUNT. MOT. ASSY. - 1PH/1HP/115/230V (6)	816676-062	
1	RIGID MOUNT. MOT. ASSY. - 3PH/1HP/208/230/460V (6)	816676-069	
1	RIGID MOUNT. MOT. ASSY. - 3PH/1HP/575V (6)	811757-009	
17	RIGID MT. MTR. CAPSCREWS 3/8-16X7/8 (4 Req'd)	911121-107	
6	SHAFT & SLEEVE ASSEMBLY (S/S Sleeve)	816354-071	
19	WATER SLINGER	116368-000	

- NOTES:** (1) Bearing Assembly does not include Coverplate, Mechanical Seal Assembly, Ceramic Seat or Retainer Cup.
(2) Bearing Assembly Kit includes B/F Coverplate, Mechanical Seal Assembly, Ceramic Seat and Retainer Cup.
(3) 874112-000 Brg/Cap assy.Kit includes Brg/Cap Assy., "O" Ring, Oil Seal & Oil Wick.
(4) For TEFC or Explosion Proof Motors, contact the factory.

CIRCULATOR PARTS

MODEL NUMBER H66 - SIZE 6 Serial No. 6505 & Later STANDARD BRONZE FITTED CONSTRUCTION

ITEM NO.	DESCRIPTION	PART NUMBER	ARMSTRONG BAR CODE
35	BEARING ASSEMBLY (1)	816366-041	
35	BEARING ASSEMBLY KIT C/W Seal Kit & Cover Plate (2)	816861-041	
10	BEARING BRACKET	816342-011	
4	BEARING CAP ASSEMBLY (3)	874112-000	
3	BEARING CAP CAPSCREWS 1/4-20X5/8	911117-105	
29	BODY	816174-011	
21	BODY CAPS. - 3/8-16X7/8	911121-107	
28	BODY GASKET	106592-000	
2	COUPLER ASSEMBLY (Flexible) 5/8X5/8	816665-000	
15	COUPLER GUARD	116114-000	
0	COUPLER INSERT	875000-801	
7	COUPLER KEY (Woodruff #9)	974515-100	
20	COVERPLATE (Cast Iron)	816346-011	
18	COVERPLATE CAPSCREWS 5/16-18X3/4	911119-106	
31	FLANGE -2" NPT - (Cast Iron)	106074-011	
32	FLANGE BOLTS - 1/2-13X2 1/4"	911125-100	
30	FLANGE GASKET	116117-000	
-	FLANGE NUTS - 1/2-13	913125-100	
25	IMPELLER (Brass) 5 5/8"	816393-052	
8	IMPELLER KEY (WOODRUFF #3)	974508-100	
27	IMPELLER NUT 7/16-20NF (Bronze)	116406-000	
26	IMPELLER WASHER	927412-700	
15	MECH. SEAL ASSY. (Brass Buna)	816707-001	
15	MECH. SEAL ASSY. (Brass Viton High Temp. 225F-275F)	816707-003	
14	OIL LEVEL WINDOW	116904-001	
9	OIL SLINGER	116369-000	
12	OIL WELL COVER ASSEMBLY	116361-000	
11	OIL WELL COVER GASKET	116400-000	
-	OIL WICKS (3/8X1/2)	816565-000	
1	RESILIENT MTD. MOT. ASSY. - 1PH/3/4HP/115/230V	811757-002	
17	RES. MTD. MTR. CAPSCREWS 3/8-16X5/8 (4 Req'd)	911121-106	
1	RIGID MOUNT. MOT. ASSY. - 1PH/3/4HP/115/230V (4)	831010-062	
1	RIGID MOUNT. MOT. ASSY. - 3PH/3/4HP/208/230/460V (4)	831012-083	
1	RIGID MOUNT. MOT. ASSY. - 3PH/3/4HP/575V (4)	811757-006	
17	RIGID MT. MTR. CAPSCREWS 3/8-16X7/8 (4 Req'd)	911121-107	
6	SHAFT & SLEEVE ASSEMBLY	816354-041	
6	SHAFT & SLEEVE ASSY. (S/S Sleeve)	816354-071	
19	WATER SLINGER	116368-000	

- NOTES:** (1) Bearing Assembly does not include Coverplate, Mechanical Seal Assembly, Ceramic Seat or Retainer Cup.
 (2) Bearing Assembly Kit includes B/F Coverplate, Mechanical Seal Assembly, Ceramic Seat and Retainer Cup.
 (3) 874112-000 Brg/Cap assy.Kit includes Brg/Cap Assy., "O" Ring, Oil Seal & Oil Wick.
 (4) For TEFC or Explosion Proof Motors, contact the factory.

CIRCULATOR PARTS

MODEL NUMBER H66 - SIZE 6 Serial No. 6505 & Later ALL BRONZE CONSTRUCTION

ITEM NO.	DESCRIPTION	PART NUMBER	ARMSTRONG BAR CODE
35	BEARING ASSEMBLY (1)	816366-041	
35	BEARING ASSEMBLY KIT C/W Seal Kit & Cover Plate (2)	816861-041	
10	BEARING BRACKET	816342-011	
4	BEARING CAP ASSEMBLY (3)	874112-000	
3	BEARING CAP CAPSCREWS 1/4-20X5/8	911117-105	
29	BODY	816174-041	
21	BODY CAPS. - 3/8-16X7/8	911121-107	
28	BODY GASKET	106592-000	
2	COUPLER ASSEMBLY (Flexible) 5/8X5/8	816665-000	
15	COUPLER GUARD	116114-000	
0	COUPLER INSERT	875000-801	
7	COUPLER KEY (Woodruff #9)	974515-100	
20	COVERPLATE (Bronze)	816346-041	
18	COVERPLATE CAPSCREWS 5/16-18X3/4	911119-106	
31	FLANGE -2" NPT - (Bronze)	106074-041	
32	FLANGE BOLTS - 1/2-13X2 1/4"	911125-100	
30	FLANGE GASKET	116117-000	
-	FLANGE NUTS - 1/2-13	913125-100	
25	IMPELLER (Brass) 5 5/8"	816393-052	
8	IMPELLER KEY (WOODRUFF #3)	974508-100	
27	IMPELLER NUT 7/16-20NF (Bronze)	116406-000	
26	IMPELLER WASHER	927412-700	
15	MECH. SEAL ASSY. (Brass Buna)	816707-001	
15	MECH. SEAL ASSY. (Brass Viton High Temp. 225F-275F)	816707-003	
14	OIL LEVEL WINDOW	116904-001	
9	OIL SLINGER	116369-000	
12	OIL WELL COVER ASSEMBLY	116361-000	
11	OIL WELL COVER GASKET	116400-000	
-	OIL WICKS (3/8X1/2)	816565-000	
1	RESILIENT MTD. MOT. ASSY. - 1PH/3/4HP/115/230V	811757-002	
17	RES. MTD. MTR. CAPSCREWS 3/8-16X5/8 (4 Req'd)	911121-106	
1	RIGID MOUNT. MOT. ASSY. - 1PH/3/4HP/115/230V (4)	831010-062	
1	RIGID MOUNT. MOT. ASSY. - 3PH/3/4HP/208/230/460V (4)	831012-083	
1	RIGID MOUNT. MOT. ASSY. - 3PH/3/4HP/575V (4)	811757-006	
17	RIGID MT. MTR. CAPSCREWS 3/8-16X7/8 (4 Req'd)	911121-107	
6	SHAFT & SLEEVE ASSEMBLY	816354-041	
6	SHAFT & SLEEVE ASSY. (S/S Sleeve)	816354-071	
19	WATER SLINGER	116368-000	

- NOTES:** (1) Bearing Assembly does not include Coverplate, Mechanical Seal Assembly, Ceramic Seat or Retainer Cup.
(2) Bearing Assembly Kit includes B/F Coverplate, Mechanical Seal Assembly, Ceramic Seat and Retainer Cup.
(3) 874112-000 Brg/Cap assy.Kit includes Brg/Cap Assy., "O" Ring, Oil Seal & Oil Wick.
(4) For TEFC or Explosion Proof Motors, contact the factory.

CIRCULATOR PARTS

MODEL NUMBER H66 - SIZE 6 Serial No. 6505 & Later ALL IRON CONSTRUCTION

ITEM NO.	DESCRIPTION	PART NUMBER	ARMSTRONG BAR CODE
35	BEARING ASSEMBLY (1)	816366-071	
35	BEARING ASSEMBLY KIT C/W Seal Kit & Cover Plate (2)	816861-071	
10	BEARING BRACKET	816342-011	
4	BEARING CAP ASSEMBLY (3)	874112-000	
3	BEARING CAP CAPSCREWS 1/4-20X5/8	911117-105	
29	BODY	816174-011	
21	BODY CAPS. - 3/8-16X7/8	911121-107	
28	BODY GASKET	106592-000	
2	COUPLER ASSEMBLY (Flexible) 5/8X5/8	816665-000	
15	COUPLER GUARD	116114-000	
0	COUPLER INSERT	875000-801	
7	COUPLER KEY (Woodruff #9)	974515-100	
20	COVERPLATE (Cast Iron)	816346-011	
18	COVERPLATE CAPSCREWS 5/16-18X3/4	911119-106	
31	FLANGE -2" NPT - (Cast Iron)	106074-011	
32	FLANGE BOLTS - 1/2-13X2 1/4"	911125-100	
30	FLANGE GASKET	116117-000	
-	FLANGE NUTS - 1/2-13	913125-100	
25	IMPELLER (Steel) 5 5/8"	816393-052	
8	IMPELLER KEY (WOODRUFF #3)	974508-100	
27	IMPELLER NUT 7/16-20NF (Steel)	913173-100	
26	IMPELLER WASHER	927412-700	
15	MECH. SEAL ASSY. (Steel Buna)	816707-002	
15	MECH. SEAL ASSY. (Steel Viton High Temp. 225F-275F)	816707-004	
14	OIL LEVEL WINDOW	116904-001	
9	OIL SLINGER	116369-000	
12	OIL WELL COVER ASSEMBLY	116361-000	
11	OIL WELL COVER GASKET	116400-000	
-	OIL WICKS (3/8X1/2)	816565-000	
1	RESILIENT MTD. MOT. ASSY. - 1PH/3/4HP/115/230V	811757-002	
17	RES. MTD. MTR. CAPSCREWS 3/8-16X5/8 (4 Req'd)	911121-106	
1	RIGID MOUNT. MOT. ASSY. - 1PH/3/4HP/115/230V (4)	831010-062	
1	RIGID MOUNT. MOT. ASSY. - 3PH/3/4HP/208/230/460V (4)	831012-083	
1	RIGID MOUNT. MOT. ASSY. - 3PH/3/4HP/575V (4)	811757-006	
17	RIGID MT. MTR. CAPSCREWS 3/8-16X7/8 (4 Req'd)	911121-107	
6	SHAFT & SLEEVE ASSEMBLY (S/S Sleeve)	816354-071	
19	WATER SLINGER	116368-000	

- NOTES:** (1) Bearing Assembly does not include Coverplate, Mechanical Seal Assembly, Ceramic Seat or Retainer Cup.
(2) Bearing Assembly Kit includes B/F Coverplate, Mechanical Seal Assembly, Ceramic Seat and Retainer Cup.
(3) 874112-000 Brg/Cap assy.Kit includes Brg/Cap Assy., "O" Ring, Oil Seal & Oil Wick.
(4) For TEFC or Explosion Proof Motors, contact the factory.

CIRCULATOR PARTS

MODEL NUMBER H67 - SIZE 6 Serial No. 6505 & Later			
STANDARD BRONZE FITTED CONSTRUCTION			
ITEM NO.	DESCRIPTION	PART NUMBER	ARMSTRONG BAR CODE
35	BEARING ASSEMBLY (1)	816366-041	
35	BEARING ASSEMBLY KIT C/W Seal Kit & Cover Plate (2)	816861-041	
10	BEARING BRACKET	816342-011	
4	BEARING CAP ASSEMBLY (3)	874112-000	
3	BEARING CAP CAPSCREWS 1/4-20X5/8	911117-105	
29	BODY	816174-011	
21	BODY CAPS. - 3/8-16X7/8	911121-107	
28	BODY GASKET	106592-000	
2	COUPLER ASSEMBLY (Flexible) 5/8X5/8	816665-000	
15	COUPLER GUARD	116114-000	
0	COUPLER INSERT	875000-801	
7	COUPLER KEY (Woodruff #9)	974515-100	
20	COVERPLATE (Cast Iron)	816346-011	
18	COVERPLATE CAPSCREWS 5/16-18X3/4	911119-106	
31	FLANGE -2" NPT - (Cast Iron)	106074-011	
32	FLANGE BOLTS - 1/2-13X2 1/4"	911125-100	
30	FLANGE GASKET	116117-000	
-	FLANGE NUTS - 1/2-13	913125-100	
25	IMPELLER (Brass) 6 1/4"	816393-047	
8	IMPELLER KEY (WOODRUFF #3)	974508-100	
27	IMPELLER NUT 7/16-20NF (Bronze)	116406-000	
26	IMPELLER WASHER	927412-700	
15	MECH. SEAL ASSY. (Brass Buna)	816707-001	
15	MECH. SEAL ASSY. (Brass Viton High Temp. 225F-275F)	816707-003	
14	OIL LEVEL WINDOW	116904-001	
9	OIL SLINGER	116369-000	
12	OIL WELL COVER ASSEMBLY	116361-000	
11	OIL WELL COVER GASKET	116400-000	
-	OIL WICKS (3/8X1/2)	816565-000	
1	RESILIENT MTD. MOT. ASSY. - 1PH/3/4HP/115/230V	811757-002	
17	RES. MTD. MTR. CAPSCREWS 3/8-16X5/8 (4 Req'd)	911121-106	
1	RIGID MOUNT. MOT. ASSY. - 1PH/3/4HP/115/230V (4)	831010-062	
1	RIGID MOUNT. MOT. ASSY. - 3PH/3/4HP/208/230/460V (4)	831012-083	
1	RIGID MOUNT. MOT. ASSY. - 3PH/3/4HP/575V (4)	811757-006	
17	RIGID MT. MTR. CAPSCREWS 3/8-16X7/8 (4 Req'd)	911121-107	
6	SHAFT & SLEEVE ASSEMBLY	816354-041	
6	SHAFT & SLEEVE ASSY. (S/S Sleeve)	816354-071	
19	WATER SLINGER	116368-000	

- NOTES:** (1) Bearing Assembly does not include Coverplate, Mechanical Seal Assembly, Ceramic Seat or Retainer Cup.
(2) Bearing Assembly Kit includes B/F Coverplate, Mechanical Seal Assembly, Ceramic Seat and Retainer Cup.
(3) 874112-000 Brg/Cap assy.Kit includes Brg/Cap Assy., "O" Ring, Oil Seal & Oil Wick.
(4) For TEFC or Explosion Proof Motors, contact the factory.

CIRCULATOR PARTS

MODEL NUMBER H67 - SIZE 6 Serial No. 6505 & Later ALL BRONZE CONSTRUCTION

ITEM NO.	DESCRIPTION	PART NUMBER	ARMSTRONG BAR CODE
35	BEARING ASSEMBLY (1)	816366-041	
35	BEARING ASSEMBLY KIT C/W Seal Kit & Cover Plate (2)	816861-041	
10	BEARING BRACKET	816342-011	
4	BEARING CAP ASSEMBLY (3)	874112-000	
3	BEARING CAP CAPSCREWS 1/4-20X5/8	911117-105	
29	BODY	816174-041	
21	BODY CAPS. - 3/8-16X7/8	911121-107	
28	BODY GASKET	106592-000	
2	COUPLER ASSEMBLY (Flexible) 5/8X5/8	816665-000	
15	COUPLER GUARD	116114-000	
0	COUPLER INSERT	875000-801	
7	COUPLER KEY (Woodruff #9)	974515-100	
20	COVERPLATE (Bronze)	816346-041	
18	COVERPLATE CAPSCREWS 5/16-18X3/4	911119-106	
31	FLANGE -2" NPT - (Bronze)	106074-041	
32	FLANGE BOLTS - 1/2-13X2 1/4"	911125-100	
30	FLANGE GASKET	116117-000	
-	FLANGE NUTS - 1/2-13	913125-100	
25	IMPELLER (Brass) 6 1/4"	816393-047	
8	IMPELLER KEY (WOODRUFF #3)	974508-100	
27	IMPELLER NUT 7/16-20NF (Bronze)	116406-000	
26	IMPELLER WASHER	927412-700	
15	MECH. SEAL ASSY. (Brass Buna)	816707-001	
15	MECH. SEAL ASSY. (Brass Viton High Temp. 225F-275F)	816707-003	
14	OIL LEVEL WINDOW	116904-001	
9	OIL SLINGER	116369-000	
12	OIL WELL COVER ASSEMBLY	116361-000	
11	OIL WELL COVER GASKET	116400-000	
-	OIL WICKS (3/8X1/2)	816565-000	
1	RESILIENT MTD. MOT. ASSY. - 1PH/3/4HP/115/230V	811757-002	
17	RES. MTD. MTR. CAPSCREWS 3/8-16X5/8 (4 Req'd)	911121-106	
1	RIGID MOUNT. MOT. ASSY. - 1PH/3/4HP/115/230V (4)	831010-062	
1	RIGID MOUNT. MOT. ASSY. - 3PH/3/4HP/208/230/460V (4)	831012-083	
1	RIGID MOUNT. MOT. ASSY. - 3PH/3/4HP/575V (4)	811757-006	
17	RIGID MT. MTR. CAPSCREWS 3/8-16X7/8 (4 Req'd)	911121-107	
6	SHAFT & SLEEVE ASSEMBLY	816354-041	
6	SHAFT & SLEEVE ASSY. (S/S Sleeve)	816354-071	
19	WATER SLINGER	116368-000	

- NOTES:** (1) Bearing Assembly does not include Coverplate, Mechanical Seal Assembly, Ceramic Seat or Retainer Cup.
(2) Bearing Assembly Kit includes B/F Coverplate, Mechanical Seal Assembly, Ceramic Seat and Retainer Cup.
(3) 874112-000 Brg/Cap assy.Kit includes Brg/Cap Assy., "O" Ring, Oil Seal & Oil Wick.
(4) For TEFC or Explosion Proof Motors, contact the factory.

CIRCULATOR PARTS

MODEL NUMBER H67 - SIZE 6 Serial No. 6505 & Later ALL IRON CONSTRUCTION

ITEM NO.	DESCRIPTION	PART NUMBER	ARMSTRONG BAR CODE
35	BEARING ASSEMBLY (1)	816366-071	
35	BEARING ASSEMBLY KIT C/W Seal Kit & Cover Plate (2)	816861-071	
10	BEARING BRACKET	816342-011	
4	BEARING CAP ASSEMBLY (3)	874112-000	
3	BEARING CAP CAPSCREWS 1/4-20X5/8	911117-105	
29	BODY	816174-011	
21	BODY CAPS. - 3/8-16X7/8	911121-107	
28	BODY GASKET	106592-000	
2	COUPLER ASSEMBLY (Flexible) 5/8X5/8	816665-000	
15	COUPLER GUARD	116114-000	
0	COUPLER INSERT	875000-801	
7	COUPLER KEY (Woodruff #9)	974515-100	
20	COVERPLATE (Cast Iron)	816346-011	
18	COVERPLATE CAPSCREWS 5/16-18X3/4	911119-106	
31	FLANGE -2" NPT - (Cast Iron)	106074-011	
32	FLANGE BOLTS - 1/2-13X2 1/4"	911125-100	
30	FLANGE GASKET	116117-000	
-	FLANGE NUTS - 1/2-13	913125-100	
25	IMPELLER (Steel) 6 1/4"	816393-017	
8	IMPELLER KEY (WOODRUFF #3)	974508-100	
27	IMPELLER NUT 7/16-20NF (Steel)	913173-100	
26	IMPELLER WASHER	927412-700	
15	MECH. SEAL ASSY. (Steel Buna)	816707-002	
15	MECH. SEAL ASSY. (Steel Viton High Temp. 225F-275F)	816707-004	
14	OIL LEVEL WINDOW	116904-001	
9	OIL SLINGER	116369-000	
12	OIL WELL COVER ASSEMBLY	116361-000	
11	OIL WELL COVER GASKET	116400-000	
-	OIL WICKS (3/8X1/2)	816565-000	
1	RESILIENT MTD. MOT. ASSY. - 1PH/3/4HP/115/230V	811757-002	
17	RES. MTD. MTR. CAPSCREWS 3/8-16X5/8 (4 Req'd)	911121-106	
1	RIGID MOUNT. MOT. ASSY. - 1PH/3/4HP/115/230V (4)	831010-062	
1	RIGID MOUNT. MOT. ASSY. - 3PH/3/4HP/208/230/460V (4)	831012-083	
1	RIGID MOUNT. MOT. ASSY. - 3PH/3/4HP/575V (4)	811757-006	
17	RIGID MT. MTR. CAPSCREWS 3/8-16X7/8 (4 Req'd)	911121-107	
6	SHAFT & SLEEVE ASSEMBLY (S/S Sleeve)	816354-071	
19	WATER SLINGER	116368-000	

- NOTES:** (1) Bearing Assembly does not include Coverplate, Mechanical Seal Assembly, Ceramic Seat or Retainer Cup.
(2) Bearing Assembly Kit includes B/F Coverplate, Mechanical Seal Assembly, Ceramic Seat and Retainer Cup.
(3) 874112-000 Brg/Cap assy.Kit includes Brg/Cap Assy., "O" Ring, Oil Seal & Oil Wick.
(4) For TEFC or Explosion Proof Motors, contact the factory.

CIRCULATOR PARTS

MODEL NUMBER H68 - SIZE 6 Serial No. 6505 & Later STANDARD BRONZE FITTED CONSTRUCTION

ITEM NO.	DESCRIPTION	PART NUMBER	ARMSTRONG BAR CODE
35	BEARING ASSEMBLY (1)	816366-041	
35	BEARING ASSEMBLY KIT C/W Seal Kit & Cover Plate (2)	816861-041	
10	BEARING BRACKET	816342-011	
4	BEARING CAP ASSEMBLY (3)	874112-000	
3	BEARING CAP CAPSCREWS 1/4-20X5/8	911117-105	
29	BODY	816174-011	
21	BODY CAPS. - 3/8-16X7/8	911121-107	
28	BODY GASKET	106592-000	
2	COUPLER ASSEMBLY (Flexible) 5/8X5/8	816665-000	
15	COUPLER GUARD	116114-000	
0	COUPLER INSERT	875000-801	
7	COUPLER KEY (Woodruff #9)	974515-100	
20	COVERPLATE (Cast Iron)	816346-011	
18	COVERPLATE CAPSCREWS 5/16-18X3/4	911119-106	
31	FLANGE -2" NPT - (Cast Iron)	106074-011	
32	FLANGE BOLTS - 1/2-13X2 1/4"	911125-100	
30	FLANGE GASKET	116117-000	
-	FLANGE NUTS - 1/2-13	913125-100	
25	IMPELLER (Brass) 6 3/4"	816393-043	
8	IMPELLER KEY (WOODRUFF #3)	974508-100	
27	IMPELLER NUT 7/16-20NF (Bronze)	116406-000	
26	IMPELLER WASHER	927412-700	
15	MECH. SEAL ASSY. (Brass Buna)	816707-001	
15	MECH. SEAL ASSY. (Brass Viton High Temp. 225F-275F)	816707-003	
14	OIL LEVEL WINDOW	116904-001	
9	OIL SLINGER	116369-000	
12	OIL WELL COVER ASSEMBLY	116361-000	
11	OIL WELL COVER GASKET	116400-000	
-	OIL WICKS (3/8X1/2)	816565-000	
1	RESILIENT MTD. MOT. ASSY. - 1PH/1 1/2HP/115/230V	811757-028	
17	RES. MTD. MTR. CAPSCREWS 3/8-16X5/8 (4 Req'd)	911121-106	
1	RIGID MOUNT. MOT. ASSY. - 1PH/1 1/2HP/115/230V (4)	816678-062	
1	RIGID MOUNT. MOT. ASSY. - 3PH/1 1/2HP/208/230/460V (4)	816678-069	
1	RIGID MOUNT. MOT. ASSY. - 3PH/1 1/2HP/575V (4)	816685-068	
17	RIGID MT. MTR. CAPSCREWS 3/8-16X7/8 (4 Req'd)	911121-107	
6	SHAFT & SLEEVE ASSEMBLY	816354-041	
6	SHAFT & SLEEVE ASSY. (S/S Sleeve)	816354-071	
19	WATER SLINGER	116368-000	

- NOTES:** (1) Bearing Assembly does not include Coverplate, Mechanical Seal Assembly, Ceramic Seat or Retainer Cup.
 (2) Bearing Assembly Kit includes B/F Coverplate, Mechanical Seal Assembly, Ceramic Seat and Retainer Cup.
 (3) 874112-000 Brg/Cap assy.Kit includes Brg/Cap Assy., "O" Ring, Oil Seal & Oil Wick.
 (4) For TEFC or Explosion Proof Motors, contact the factory.

CIRCULATOR PARTS

MODEL NUMBER H68 - SIZE 6 Serial No. 6505 & Later ALL BRONZE CONSTRUCTION

ITEM NO.	DESCRIPTION	PART NUMBER	ARMSTRONG BAR CODE
35	BEARING ASSEMBLY (1)	816366-041	
35	BEARING ASSEMBLY KIT C/W Seal Kit & Cover Plate (2)	816861-041	
10	BEARING BRACKET	816342-011	
4	BEARING CAP ASSEMBLY (3)	874112-000	
3	BEARING CAP CAPSCREWS 1/4-20X5/8	911117-105	
29	BODY	816174-041	
21	BODY CAPS. - 3/8-16X7/8	911121-107	
28	BODY GASKET	106592-000	
2	COUPLER ASSEMBLY (Flexible) 5/8X5/8	816665-000	
15	COUPLER GUARD	116114-000	
0	COUPLER INSERT	875000-801	
7	COUPLER KEY (Woodruff #9)	974515-100	
20	COVERPLATE (Bronze)	816346-041	
18	COVERPLATE CAPSCREWS 5/16-18X3/4	911119-106	
31	FLANGE -2" NPT - (Bronze)	106074-041	
32	FLANGE BOLTS - 1/2-13X2 1/4"	911125-100	
30	FLANGE GASKET	116117-000	
-	FLANGE NUTS - 1/2-13	913125-100	
25	IMPELLER (Brass) 6 3/4"	816393-043	
8	IMPELLER KEY (WOODRUFF #3)	974508-100	
27	IMPELLER NUT 7/16-20NF (Bronze)	116406-000	
26	IMPELLER WASHER	927412-700	
15	MECH. SEAL ASSY. (Brass Buna)	816707-001	
15	MECH. SEAL ASSY. (Brass Viton High Temp. 225F-275F)	816707-003	
14	OIL LEVEL WINDOW	116904-001	
9	OIL SLINGER	116369-000	
12	OIL WELL COVER ASSEMBLY	116361-000	
11	OIL WELL COVER GASKET	116400-000	
-	OIL WICKS (3/8X1/2)	816565-000	
1	RESILIENT MTD. MOT. ASSY. - 1PH/1 1/2HP/115/230V	811757-028	
17	RES. MTD. MTR. CAPSCREWS 3/8-16X5/8 (4 Req'd)	911121-106	
1	RIGID MOUNT. MOT. ASSY. - 1PH/1 1/2HP/115/230V (4)	816678-062	
1	RIGID MOUNT. MOT. ASSY. - 3PH/1 1/2HP/208/230/460V (4)	816678-069	
1	RIGID MOUNT. MOT. ASSY. - 3PH/1 1/2HP/575V (4)	816685-068	
17	RIGID MT. MTR. CAPSCREWS 3/8-16X7/8 (4 Req'd)	911121-107	
6	SHAFT & SLEEVE ASSEMBLY	816354-041	
6	SHAFT & SLEEVE ASSY. (S/S Sleeve)	816354-071	
19	WATER SLINGER	116368-000	

- NOTES:** (1) Bearing Assembly does not include Coverplate, Mechanical Seal Assembly, Ceramic Seat or Retainer Cup.
(2) Bearing Assembly Kit includes B/F Coverplate, Mechanical Seal Assembly, Ceramic Seat and Retainer Cup.
(3) 874112-000 Brg/Cap assy.Kit includes Brg/Cap Assy., "O" Ring, Oil Seal & Oil Wick.
(4) For TEFC or Explosion Proof Motors, contact the factory.

CIRCULATOR PARTS

MODEL NUMBER H68 - SIZE 6 Serial No. 6505 & Later ALL IRON CONSTRUCTION

ITEM NO.	DESCRIPTION	PART NUMBER	ARMSTRONG BAR CODE
35	BEARING ASSEMBLY (1)	816366-071	
35	BEARING ASSEMBLY KIT C/W Seal Kit & Cover Plate (2)	816861-071	
10	BEARING BRACKET	816342-011	
4	BEARING CAP ASSEMBLY (3)	874112-000	
3	BEARING CAP CAPSCREWS 1/4-20X5/8	911117-105	
29	BODY	816174-011	
21	BODY CAPS. - 3/8-16X7/8	911121-107	
28	BODY GASKET	106592-000	
2	COUPLER ASSEMBLY (Flexible) 5/8X5/8	816665-000	
15	COUPLER GUARD	116114-000	
0	COUPLER INSERT	875000-801	
7	COUPLER KEY (Woodruff #9)	974515-100	
20	COVERPLATE (Cast Iron)	816346-011	
18	COVERPLATE CAPSCREWS 5/16-18X3/4	911119-106	
31	FLANGE -2" NPT - (Cast Iron)	106074-011	
32	FLANGE BOLTS - 1/2-13X2 1/4"	911125-100	
30	FLANGE GASKET	116117-000	
-	FLANGE NUTS - 1/2-13	913125-100	
25	IMPELLER (Steel) 6 3/4"	816393-013	
8	IMPELLER KEY (WOODRUFF #3)	974508-100	
27	IMPELLER NUT 7/16-20NF (Steel)	913173-100	
26	IMPELLER WASHER	927412-700	
15	MECH. SEAL ASSY. (Steel Buna)	816707-002	
15	MECH. SEAL ASSY. (Steel Viton High Temp. 225F-275F)	816707-004	
14	OIL LEVEL WINDOW	116904-001	
9	OIL SLINGER	116369-000	
12	OIL WELL COVER ASSEMBLY	116361-000	
11	OIL WELL COVER GASKET	116400-000	
-	OIL WICKS (3/8X1/2)	816565-000	
1	RESILIENT MTD. MOT. ASSY. - 1PH/1 1/2HP/115/230V	811757-028	
17	RES. MTD. MTR. CAPSCREWS 3/8-16X5/8 (4 Req'd)	911121-106	
1	RIGID MOUNT. MOT. ASSY. - 1PH/1 1/2HP/115/230V (4)	816678-062	
1	RIGID MOUNT. MOT. ASSY. - 3PH/1 1/2HP/208/230/460V (4)	816678-069	
1	RIGID MOUNT. MOT. ASSY. - 3PH/1 1/2HP/575V (4)	816685-068	
17	RIGID MT. MTR. CAPSCREWS 3/8-16X7/8 (4 Req'd)	911121-107	
6	SHAFT & SLEEVE ASSEMBLY	816354-011	
6	SHAFT & SLEEVE ASSY. (S/S Sleeve)	816354-071	
19	WATER SLINGER	116368-000	

- NOTES:** (1) Bearing Assembly does not include Coverplate, Mechanical Seal Assembly, Ceramic Seat or Retainer Cup.
(2) Bearing Assembly Kit includes B/F Coverplate, Mechanical Seal Assembly, Ceramic Seat and Retainer Cup.
(3) 874112-000 Brg/Cap assy.Kit includes Brg/Cap Assy., "O" Ring, Oil Seal & Oil Wick.
(4) For TEFC or Explosion Proof Motors, contact the factory.

CIRCULATOR PARTS

MODEL NUMBER 1060 1 1/2D - SIZE 6 Serial No. 6505 & Later STANDARD BRONZE FITTED CONSTRUCTION

ITEM NO.	DESCRIPTION	PART NUMBER	ARMSTRONG BAR CODE
35	BEARING ASSEMBLY (1)	816366-041	
35	BEARING ASSEMBLY KIT C/W Seal Kit & Cover Plate (2)	816861-041	
10	BEARING BRACKET	816342-011	
4	BEARING CAP ASSEMBLY (3)	874112-000	
3	BEARING CAP CAPSCREWS 1/4-20X5/8	911117-105	
29	BODY	816397-011	
21	BODY CAPS. - 3/8-16X7/8	911121-107	
28	BODY GASKET	106592-000	
2	COUPLER ASSEMBLY (Flexible) 5/8X5/8	816665-000	
15	COUPLER GUARD	116114-000	
0	COUPLER INSERT	875000-801	
7	COUPLER KEY (Woodruff #9)	974515-100	
20	COVERPLATE (Cast Iron)	816346-011	
18	COVERPLATE CAPSCREWS 5/16-18X3/4	911119-106	
31	FLANGE -1 1/2" NPT - (Cast Iron)	104301-011	
32	FLANGE BOLTS - 7/16-14X2	911123-116	
30	FLANGE GASKET	104034-000	
-	FLANGE NUTS - 7/16-14	913129-100	
25	IMPELLER (Brass) 7" Dia.	874058-041	
25	IMPELLER (Brass) 6 1/2" Dia.	874058-045	
25	IMPELLER (Brass) 6" Dia.	874058-049	
25	IMPELLER (Brass) 5 1/2" Dia.	874058-053	
25	IMPELLER (Brass) 5" Dia.	874058-057	
8	IMPELLER KEY (WOODRUFF #3)	974508-100	
27	IMPELLER NUT 7/16-20NF (Bronze)	116406-000	
26	IMPELLER WASHER	927412-700	
15	MECH. SEAL ASSY. (Brass Buna)	816707-001	
15	MECH. SEAL ASSY. (Brass Viton High Temp. 225F-275F)	816707-003	
14	OIL LEVEL WINDOW	116904-001	
9	OIL SLINGER	116369-000	
12	OIL WELL COVER ASSEMBLY	116361-000	
11	OIL WELL COVER GASKET	116400-000	
-	OIL WICKS (3/8X1/2)	816565-000	
1	RESILIENT MTD. MOT. ASSY. - 1PH/1/2HP/115/230V	811757-001	
1	RESILIENT MTD. MOT. ASSY. - 1PH/3/4HP/115/230V	811757-002	
1	RESILIENT MTD. MOT. ASSY. - 1PH/1HP/115V/230	811757-007	
17	RES. MTD. MTR. CAPSCREWS 3/8-16X5/8 (4 Req'd)	911121-106	
1	RIGID MOUNT. MOT. ASSY. - 1PH /1/2HP/115/230V (4)	831009-062	
1	RIGID MOUNT. MOT. ASSY. - 1PH/3/4HP/115/230V (4)	831010-062	
1	RIGID MOUNT. MOT. ASSY. - 1PH/1HP/115/230V (4)	816676-062	
1	RIGID MOUNT. MOT. ASSY. - 1PH/1 1/2HP/115/230V (4)	816678-062	
1	RIGID MOUNT. MOT. ASSY. - 3PH/1/2HP/208/230/460V (4)	831011-083	
1	RIGID MOUNT. MOT. ASSY. - 3PH/3/4HP/208/230/460V (4)	831012-083	
1	RIGID MOUNT. MOT. ASSY. - 3PH/1HP/208/230/460V (4)	816676-069	
1	RIGID MOUNT. MOT. ASSY. - 3PH/1 1/2HP/208/230/460V (4)	816678-069	
1	RIGID MOUNT. MOT. ASSY. - 3PH/1/2HP/575V (4)	811757-004	
1	RIGID MOUNT. MOT. ASSY. - 3PH/3/4HP/575V (4)	816678-068	
1	RIGID MOUNT. MOT. ASSY. - 3PH/1HP/575V (4)	811757-009	
1	RIGID MOUNT. MOT. ASSY. - 3PH/1 1/2HP/575V (4)	816685-068	
17	RIGID MT. MTR. CAPSCREWS 3/8-16X7/8 (4 Req'd)	911121-107	
6	SHAFT & SLEEVE ASSEMBLY	816354-041	
6	SHAFT & SLEEVE ASSY. (S/S Sleeve)	816354-071	
19	WATER SLINGER	116368-000	

NOTES: (1) Bearing Assembly does not include Coverplate, Mechanical Seal Assembly, Ceramic Seat or Retainer Cup.
(2) Bearing Assembly Kit includes B/F Coverplate, Mechanical Seal Assembly, Ceramic Seat and Retainer Cup.
(3) 874112-000 Brg/Cap assy.Kit includes Brg/Cap Assy., "O" Ring, Oil Seal & Oil Wick.
(4) For TEFC or Explosion Proof Motors, contact the factory.

CIRCULATOR PARTS

MODEL NUMBER 1060 1 1/2D - SIZE 6 Serial No. 6505 & Later ALL BRONZE CONSTRUCTION

ITEM NO.	DESCRIPTION	PART NUMBER	ARMSTRONG BAR CODE
35	BEARING ASSEMBLY (1)	816366-041	
35	BEARING ASSEMBLY KIT C/W Seal Kit & Cover Plate (2)	816861-041	
10	BEARING BRACKET	816342-011	
4	BEARING CAP ASSEMBLY (3)	874112-000	
3	BEARING CAP CAPSCREWS 1/4-20X5/8	911117-105	
29	BODY	816397-041	
21	BODY CAPS. - 3/8-16X7/8	911121-107	
28	BODY GASKET	106592-000	
2	COUPLER ASSEMBLY (Flexible) 5/8X5/8	816665-000	
15	COUPLER GUARD	116114-000	
0	COUPLER INSERT	875000-801	
7	COUPLER KEY (Woodruff #9)	974515-100	
20	COVERPLATE (Bronze)	816346-041	
18	COVERPLATE CAPSCREWS 5/16-18X3/4	911119-106	
31	FLANGE -1 1/2" NPT - (Bronze)	104301-041	
32	FLANGE BOLTS - 7/16-14X2	911123-116	
30	FLANGE GASKET	104034-000	
-	FLANGE NUTS - 7/16-14	913129-100	
25	IMPELLER (Brass) 7" Dia.	874058-041	
25	IMPELLER (Brass) 6 1/2" Dia.	874058-045	
25	IMPELLER (Brass) 6" Dia.	874058-049	
25	IMPELLER (Brass) 5 1/2" Dia.	874058-053	
25	IMPELLER (Brass) 5" Dia.	874058-057	
8	IMPELLER KEY (WOODRUFF #3)	974508-100	
27	IMPELLER NUT 7/16-20NF (Bronze)	116406-000	
26	IMPELLER WASHER	927412-700	
15	MECH. SEAL ASSY. (Brass Buna)	816707-001	
15	MECH. SEAL ASSY. (Brass Viton High Temp. 225F-275F)	816707-003	
14	OIL LEVEL WINDOW	116904-001	
9	OIL SLINGER	116369-000	
12	OIL WELL COVER ASSEMBLY	116361-000	
11	OIL WELL COVER GASKET	116400-000	
-	OIL WICKS (3/8X1/2)	816565-000	
1	RESILIENT MTD. MOT. ASSY. - 1PH/1/2HP/115/230V	811757-001	
1	RESILIENT MTD. MOT. ASSY. - 1PH/3/4HP/115/230V	811757-002	
1	RESILIENT MTD. MOT. ASSY. - 1PH/1HP/115V/230	811757-007	
17	RES. MTD. MTR. CAPSCREWS 3/8-16X5/8 (4 Req'd)	911121-106	
1	RIGID MOUNT. MOT. ASSY. - 1PH /1/2HP/115/230V (4)	831009-062	
1	RIGID MOUNT. MOT. ASSY. - 1PH/3/4HP/115/230V (4)	831010-062	
1	RIGID MOUNT. MOT. ASSY. - 1PH/1HP/115/230V (4)	816676-062	
1	RIGID MOUNT. MOT. ASSY. - 1PH/1 1/2HP/115/230V (4)	816678-062	
1	RIGID MOUNT. MOT. ASSY. - 3PH/1/2HP/208/230/460V (4)	831011-083	
1	RIGID MOUNT. MOT. ASSY. - 3PH/3/4HP/208/230/460V (4)	831012-083	
1	RIGID MOUNT. MOT. ASSY. - 3PH/1HP/208/230/460V (4)	816676-069	
1	RIGID MOUNT. MOT. ASSY. - 3PH/1 1/2HP/208/230/460V (4)	816678-069	
1	RIGID MOUNT. MOT. ASSY. - 3PH/1/2HP/575V (4)	811757-004	
1	RIGID MOUNT. MOT. ASSY. - 3PH/3/4HP/575V (4)	816678-068	
1	RIGID MOUNT. MOT. ASSY. - 3PH/1HP/575V (4)	811757-009	
1	RIGID MOUNT. MOT. ASSY. - 3PH/1 1/2HP/575V (4)	816685-068	
17	RIGID MT. MTR. CAPSCREWS 3/8-16X7/8 (4 Req'd)	911121-107	
6	SHAFT & SLEEVE ASSEMBLY	816354-041	
6	SHAFT & SLEEVE ASSY. (S/S Sleeve)	816354-071	
19	WATER SLINGER	116368-000	

- NOTES:** (1) Bearing Assembly does not include Coverplate, Mechanical Seal Assembly, Ceramic Seat or Retainer Cup.
(2) Bearing Assembly Kit includes B/F Coverplate, Mechanical Seal Assembly, Ceramic Seat and Retainer Cup.
(3) 874112-000 Brg/Cap assy.Kit includes Brg/Cap Assy., "O" Ring, Oil Seal & Oil Wick.
(4) For TEFC or Explosion Proof Motors, contact the factory.

CIRCULATOR PARTS

MODEL NUMBER 1060 1 1/2D - SIZE 6 Serial No. 6505 & Later ALL IRON CONSTRUCTION

ITEM NO.	DESCRIPTION	PART NUMBER	ARMSTRONG BAR CODE
35	BEARING ASSEMBLY (1)	816366-071	
35	BEARING ASSEMBLY KIT C/W Seal Kit & Cover Plate (2)	816861-071	
10	BEARING BRACKET	816342-011	
4	BEARING CAP ASSEMBLY (3)	874112-000	
3	BEARING CAP CAPSCREWS 1/4-20X5/8	911117-105	
29	BODY	816397-011	
21	BODY CAPS. - 3/8-16X7/8	911121-107	
28	BODY GASKET	106592-000	
2	COUPLER ASSEMBLY (Flexible) 5/8X5/8	816665-000	
15	COUPLER GUARD	116114-000	
0	COUPLER INSERT	875000-801	
7	COUPLER KEY (Woodruff #9)	974515-100	
20	COVERPLATE (Cast Iron)	816346-011	
18	COVERPLATE CAPSCREWS 5/16-18X3/4	911119-106	
31	FLANGE -1 1/2" NPT - (Cast Iron)	104301-011	
32	FLANGE BOLTS - 7/16-14X2	911123-116	
30	FLANGE GASKET	104034-000	
-	FLANGE NUTS - 7/16-14	913129-100	
25	IMPELLER (Cast Iron) 7" Dia.	874058-011	
25	IMPELLER (Cast Iron) 6 1/2" Dia.	874058-015	
25	IMPELLER (Cast Iron) 6" Dia.	874058-019	
25	IMPELLER (Cast Iron) 5 1/2" Dia.	874058-023	
25	IMPELLER (Cast Iron) 5" Dia.	874058-027	
8	IMPELLER KEY (WOODRUFF #3)	974508-100	
27	IMPELLER NUT 7/16-20NF (Steel)	913173-100	
26	IMPELLER WASHER	927412-700	
15	MECH. SEAL ASSY. (Steel Buna)	816707-002	
15	MECH. SEAL ASSY. (Steel Viton High Temp. 225F-275F)	816707-004	
14	OIL LEVEL WINDOW	116904-001	
9	OIL SLINGER	116369-000	
12	OIL WELL COVER ASSEMBLY	116361-000	
11	OIL WELL COVER GASKET	116400-000	
-	OIL WICKS (3/8X1/2)	816565-000	
1	RESILIENT MTD. MOT. ASSY. - 1PH/1/2HP/115/230V	811757-001	
1	RESILIENT MTD. MOT. ASSY. - 1PH/3/4HP/115/230V	811757-002	
1	RESILIENT MTD. MOT. ASSY. - 1PH/1HP/115V/230	811757-007	
17	RES. MTD. MTR. CAPSCREWS 3/8-16X5/8 (4 Req'd)	911121-106	
1	RIGID MOUNT. MOT. ASSY. - 1PH /1/2HP/115/230 (4)	831009-062	
1	RIGID MOUNT. MOT. ASSY. - 1PH/3/4HP/115/230V (4)	831010-062	
1	RIGID MOUNT. MOT. ASSY. - 1PH/1HP/115/230V (4)	816676-062	
1	RIGID MOUNT. MOT. ASSY. - 1PH/1 1/2HP/115/230V (4)	816678-062	
1	RIGID MOUNT. MOT. ASSY. - 3PH/1/2HP/208/230/460V (4)	831011-083	
1	RIGID MOUNT. MOT. ASSY. - 3PH/3/4HP/208/230/460V (4)	831012-083	
1	RIGID MOUNT. MOT. ASSY. - 3PH/1HP/208/230/460V (4)	816676-069	
1	RIGID MOUNT. MOT. ASSY. - 3PH/1 1/2HP/208/230/460V (4)	816678-069	
1	RIGID MOUNT. MOT. ASSY. - 3PH/1/2HP/575V (4)	811757-004	
1	RIGID MOUNT. MOT. ASSY. - 3PH/3/4HP/575V (4)	816678-068	
1	RIGID MOUNT. MOT. ASSY. - 3PH/1HP/575V (4)	811757-009	
1	RIGID MOUNT. MOT. ASSY. - 3PH/1 1/2HP/575V (4)	816685-068	
17	RIGID MT. MTR. CAPSCREWS 3/8-16X7/8 (4 Req'd)	911121-107	
6	SHAFT & SLEEVE ASSEMBLY (S/S Sleeve)	816354-071	
19	WATER SLINGER	116368-000	

- NOTES:** (1) Bearing Assembly does not include Coverplate, Mechanical Seal Assembly, Ceramic Seat or Retainer Cup.
(2) Bearing Assembly Kit includes B/F Coverplate, Mechanical Seal Assembly, Ceramic Seat and Retainer Cup.
(3) 874112-000 Brg/Cap assy.Kit includes Brg/Cap Assy., "O" Ring, Oil Seal & Oil Wick.
(4) For TEFC or Explosion Proof Motors, contact the factory.

CIRCULATOR PARTS

MODEL NUMBER 1060 2D - SIZE 6 Serial No. 6505 & Later STANDARD BRONZE FITTED CONSTRUCTION

ITEM NO.	DESCRIPTION	PART NUMBER	ARMSTRONG BAR CODE
35	BEARING ASSEMBLY (1)	816366-041	
35	BEARING ASSEMBLY KIT C/W Seal Kit & Cover Plate (2)	816861-041	
10	BEARING BRACKET	816342-011	
4	BEARING CAP ASSEMBLY (3)	874112-000	
3	BEARING CAP CAPSCREWS 1/4-20X5/8	911117-105	
29	BODY	816174-011	
21	BODY CAPS. - 3/8-16X7/8	911121-107	
28	BODY GASKET	106592-000	
2	COUPLER ASSEMBLY (Flexible) 5/8X5/8	816665-000	
15	COUPLER GUARD	116114-000	
0	COUPLER INSERT	875000-801	
7	COUPLER KEY (Woodruff #9)	974515-100	
20	COVERPLATE (Cast Iron)	816346-011	
18	COVERPLATE CAPSCREWS 5/16-18X3/4	911119-106	
31	FLANGE -2" NPT - (Cast Iron)	106074-011	
32	FLANGE BOLTS - 1/2-13X2 1/4"	911125-100	
30	FLANGE GASKET	116117-000	
-	FLANGE NUTS - 1/2-13	913125-100	
25	IMPELLER (Brass) 7" Dia.	816393-041	
25	IMPELLER (Brass) 6 1/2" Dia.	816393-045	
25	IMPELLER (Brass) 6" Dia.	816393-049	
25	IMPELLER (Brass) 5 1/2" Dia.	816393-053	
25	IMPELLER (Brass) 5" Dia.	816393-057	
8	IMPELLER KEY (WOODRUFF #3)	974508-100	
27	IMPELLER NUT 7/16-20NF (Bronze)	116406-000	
26	IMPELLER WASHER	927412-700	
15	MECH. SEAL ASSY. (Brass Buna)	816707-001	
15	MECH. SEAL ASSY. (Brass Viton High Temp. 225F-275F)	816707-003	
14	OIL LEVEL WINDOW	116904-001	
9	OIL SLINGER	116369-000	
12	OIL WELL COVER ASSEMBLY	116361-000	
11	OIL WELL COVER GASKET	116400-000	
-	OIL WICKS (3/8X1/2)	816565-000	
1	RESILIENT MTD. MOT. ASSY. - 1PH/1/2HP/115/230V	811757-001	
1	RESILIENT MTD. MOT. ASSY. - 1PH/3/4HP/115/230V	811757-002	
1	RESILIENT MTD. MOT. ASSY. - 1PH/1HP/115V/230	811757-007	
17	RES. MTD. MTR. CAPSCREWS 3/8-16X5/8 (4 Req'd)	911121-106	
1	RIGID MOUNT. MOT. ASSY. - 1PH 1/2HP/115/230 (4)	831009-062	
1	RIGID MOUNT. MOT. ASSY. - 1PH/3/4HP/115/230V (4)	831010-062	
1	RIGID MOUNT. MOT. ASSY. - 1PH/1HP/115/230V (4)	816676-062	
1	RIGID MOUNT. MOT. ASSY. - 1PH/1 1/2HP/115/230V (4)	816678-062	
1	RIGID MOUNT. MOT. ASSY. - 3PH/1/2HP/208/230/460V (4)	831011-083	
1	RIGID MOUNT. MOT. ASSY. - 3PH/3/4HP/208/230/460V (4)	831012-083	
1	RIGID MOUNT. MOT. ASSY. - 3PH/1HP/208/230/460V (4)	816676-069	
1	RIGID MOUNT. MOT. ASSY. - 3PH/1 1/2HP/208/230/460V (4)	816678-069	
1	RIGID MOUNT. MOT. ASSY. - 3PH/1/2HP/575V (4)	811757-004	
1	RIGID MOUNT. MOT. ASSY. - 3PH/3/4HP/575V (4)	816678-068	
1	RIGID MOUNT. MOT. ASSY. - 3PH/1HP/575V (4)	811757-009	
1	RIGID MOUNT. MOT. ASSY. - 3PH/1 1/2HP/575V (4)	816685-068	
1	RIGID MOUNT. MOT. ASSY. - 3PH/2HP/208/230/460V (4)	816681-069	
1	RIGID MOUNT. MOT. ASSY. - 3PH/2HP/575V (4)	816686-068	
17	RIGID MT. MTR. CAPSCREWS 3/8-16X7/8 (4 Req'd)	911121-107	
6	SHAFT & SLEEVE ASSEMBLY	816354-041	
6	SHAFT & SLEEVE ASSY. (S/S Sleeve)	816354-071	
19	WATER SLINGER	116368-000	

NOTES: (1) Bearing Assembly does not include Coverplate, Mechanical Seal Assembly, Ceramic Seat or Retainer Cup.
 (2) Bearing Assembly Kit includes B/F Coverplate, Mechanical Seal Assembly, Ceramic Seat and Retainer Cup.
 (3) 874112-000 Brg/Cap assy.Kit includes Brg/Cap Assy., "O" Ring, Oil Seal & Oil Wick.
 (4) For TEFC or Explosion Proof Motors, contact the factory.

CIRCULATOR PARTS

MODEL NUMBER 1060 2D - SIZE 6 Serial No. 6505 & Later ALL BRONZE CONSTRUCTION

ITEM NO.	DESCRIPTION	PART NUMBER	ARMSTRONG BAR CODE
35	BEARING ASSEMBLY (1)	816366-041	
35	BEARING ASSEMBLY KIT C/W Seal Kit & Cover Plate (2)	816861-041	
10	BEARING BRACKET	816342-011	
4	BEARING CAP ASSEMBLY (3)	874112-000	
3	BEARING CAP CAPSCREWS 1/4-20X5/8	911117-105	
29	BODY	816174-041	
21	BODY CAPS. - 3/8-16X7/8	911121-107	
28	BODY GASKET	106592-000	
2	COUPLER ASSEMBLY (Flexible) 5/8X5/8	816665-000	
15	COUPLER GUARD	116114-000	
0	COUPLER INSERT	875000-801	
7	COUPLER KEY (Woodruff #9)	974515-100	
20	COVERPLATE (Bronze)	816346-041	
18	COVERPLATE CAPSCREWS 5/16-18X3/4	911119-106	
31	FLANGE -2" NPT - (Bronze)	106074-041	
32	FLANGE BOLTS - 1/2-13X2 1/4"	911125-100	
30	FLANGE GASKET	116117-000	
-	FLANGE NUTS - 1/2-13	913125-100	
25	IMPELLER (Brass) 7" Dia.	816393-041	
25	IMPELLER (Brass) 6 1/2" Dia.	816393-045	
25	IMPELLER (Brass) 6" Dia.	816393-049	
25	IMPELLER (Brass) 5 1/2" Dia.	816393-053	
25	IMPELLER (Brass) 5" Dia.	816393-057	
8	IMPELLER KEY (WOODRUFF #3)	974508-100	
27	IMPELLER NUT 7/16-20NF (Bronze)	116406-000	
26	IMPELLER WASHER	927412-700	
15	MECH. SEAL ASSY. (Brass Buna)	816707-001	
15	MECH. SEAL ASSY. (Brass Viton High Temp. 225F-275F)	816707-003	
14	OIL LEVEL WINDOW	116904-001	
9	OIL SLINGER	116369-000	
12	OIL WELL COVER ASSEMBLY	116361-000	
11	OIL WELL COVER GASKET	116400-000	
-	OIL WICKS (3/8X1/2)	816565-000	
1	RESILIENT MTD. MOT. ASSY. - 1PH/1/2HP/115/230V	811757-001	
1	RESILIENT MTD. MOT. ASSY. - 1PH/3/4HP/115/230V	811757-002	
1	RESILIENT MTD. MOT. ASSY. - 1PH/1HP/115V/230	811757-007	
17	RES. MTD. MTR. CAPSCREWS 3/8-16X5/8 (4 Req'd)	911121-106	
1	RIGID MOUNT. MOT. ASSY. - 1PH /1/2HP/115/230 (4)	831009-062	
1	RIGID MOUNT. MOT. ASSY. - 1PH/3/4HP/115/230V (4)	831010-062	
1	RIGID MOUNT. MOT. ASSY. - 1PH/1HP/115/230V (4)	816676-062	
1	RIGID MOUNT. MOT. ASSY. - 1PH/1 1/2HP/115/230V (4)	816678-062	
1	RIGID MOUNT. MOT. ASSY. - 3PH/1/2HP/208/230/460V (4)	831011-083	
1	RIGID MOUNT. MOT. ASSY. - 3PH/3/4HP/208/230/460V (4)	831012-083	
1	RIGID MOUNT. MOT. ASSY. - 3PH/1HP/208/230/460V (4)	816676-069	
1	RIGID MOUNT. MOT. ASSY. - 3PH/1 1/2HP/208/230/460V (4)	816678-069	
1	RIGID MOUNT. MOT. ASSY. - 3PH/1/2HP/575V (4)	811757-004	
1	RIGID MOUNT. MOT. ASSY. - 3PH/3/4HP/575V (4)	816678-068	
1	RIGID MOUNT. MOT. ASSY. - 3PH/1HP/575V (4)	811757-009	
1	RIGID MOUNT. MOT. ASSY. - 3PH/1 1/2HP/575V (4)	816685-068	
1	RIGID MOUNT. MOT. ASSY. - 3PH/2HP/208/230/460V (4)	816681-069	
1	RIGID MOUNT. MOT. ASSY. - 3PH/2HP/575V (4)	816686-068	
17	RIGID MT. MTR. CAPSCREWS 3/8-16X7/8 (4 Req'd)	911121-107	
6	SHAFT & SLEEVE ASSEMBLY	816354-041	
6	SHAFT & SLEEVE ASSY. (S/S Sleeve)	816354-071	
19	WATER SLINGER	116368-000	

NOTES: (1) Bearing Assembly does not include Coverplate, Mechanical Seal Assembly, Ceramic Seat or Retainer Cup.
(2) Bearing Assembly Kit includes B/F Coverplate, Mechanical Seal Assembly, Ceramic Seat and Retainer Cup.
(3) 874112-000 Brg/Cap assy.Kit includes Brg/Cap Assy., "O" Ring, Oil Seal & Oil Wick.
(4) For TEFC or Explosion Proof Motors, contact the factory.

CIRCULATOR PARTS

MODEL NUMBER 1060 2D - SIZE 6 Serial No. 6505 & Later ALL IRON CONSTRUCTION

ITEM NO.	DESCRIPTION	PART NUMBER	ARMSTRONG BAR CODE
35	BEARING ASSEMBLY (1)	816366-071	
35	BEARING ASSEMBLY KIT C/W Seal Kit & Cover Plate (2)	816861-071	
10	BEARING BRACKET	816342-011	
4	BEARING CAP ASSEMBLY (3)	874112-000	
3	BEARING CAP CAPSCREWS 1/4-20X5/8	911117-105	
29	BODY	816174-011	
21	BODY CAPS. - 3/8-16X7/8	911121-107	
28	BODY GASKET	106592-000	
2	COUPLER ASSEMBLY (Flexible) 5/8X5/8	816665-000	
15	COUPLER GUARD	116114-000	
0	COUPLER INSERT	875000-801	
7	COUPLER KEY (Woodruff #9)	974515-100	
20	COVERPLATE (Cast Iron)	816346-011	
18	COVERPLATE CAPSCREWS 5/16-18X3/4	911119-106	
31	FLANGE -2" NPT - (Cast Iron)	106074-011	
32	FLANGE BOLTS - 1/2-13X2 1/4"	911125-100	
30	FLANGE GASKET	116117-000	
-	FLANGE NUTS - 1/2-13	913125-100	
25	IMPELLER (Steel) 7" Dia.	816393-011	
25	IMPELLER (Steel) 6 1/2" Dia.	816393-015	
25	IMPELLER (Steel) 6" Dia.	816393-019	
25	IMPELLER (Steel) 5 1/2" Dia.	816393-023	
25	IMPELLER (Steel) 5" Dia.	816393-027	
8	IMPELLER KEY (WOODRUFF #3)	974508-100	
27	IMPELLER NUT 7/16-20NF (Steel)	913173-100	
26	IMPELLER WASHER	927412-700	
15	MECH. SEAL ASSY. (Steel Buna)	816707-002	
15	MECH. SEAL ASSY. (Steel Viton High Temp. 225F-275F)	816707-004	
14	OIL LEVEL WINDOW	116904-001	
9	OIL SLINGER	116369-000	
12	OIL WELL COVER ASSEMBLY	116361-000	
11	OIL WELL COVER GASKET	116400-000	
-	OIL WICKS (3/8X1/2)	816565-000	
1	RESILIENT MTD. MOT. ASSY. - 1PH/1/2HP/115/230V	811757-001	
1	RESILIENT MTD. MOT. ASSY. - 1PH/3/4HP/115/230V	811757-002	
1	RESILIENT MTD. MOT. ASSY. - 1PH/1HP/115V/230	811757-007	
17	RES. MTD. MTR. CAPSCREWS 3/8-16X5/8 (4 Req'd)	911121-106	
1	RIGID MOUNT. MOT. ASSY. - 1PH /1/2HP/115/230 (4)	831009-062	
1	RIGID MOUNT. MOT. ASSY. - 1PH/3/4HP/115/230V (4)	831010-062	
1	RIGID MOUNT. MOT. ASSY. - 1PH/1HP/115/230V (4)	816676-062	
1	RIGID MOUNT. MOT. ASSY. - 1PH/1 1/2HP/115/230V (4)	816678-062	
1	RIGID MOUNT. MOT. ASSY. - 3PH/1/2HP/208/230/460V (4)	831011-083	
1	RIGID MOUNT. MOT. ASSY. - 3PH/3/4HP/208/230/460V (4)	831012-083	
1	RIGID MOUNT. MOT. ASSY. - 3PH/1HP/208/230/460V (4)	816676-069	
1	RIGID MOUNT. MOT. ASSY. - 3PH/1 1/2HP/208/230/460V (4)	816678-069	
1	RIGID MOUNT. MOT. ASSY. - 3PH/1/2HP/575V (4)	811757-004	
1	RIGID MOUNT. MOT. ASSY. - 3PH/3/4HP/575V (4)	816678-068	
1	RIGID MOUNT. MOT. ASSY. - 3PH/1HP/575V (4)	811757-009	
1	RIGID MOUNT. MOT. ASSY. - 3PH/1 1/2HP/575V (4)	816685-068	
1	RIGID MOUNT. MOT. ASSY. - 3PH/2HP/208/230/460V (4)	816681-069	
1	RIGID MOUNT. MOT. ASSY. - 3PH/2HP/575V (4)	816686-068	
17	RIGID MT. MTR. CAPSCREWS 3/8-16X7/8 (4 Req'd)	911121-107	
6	SHAFT & SLEEVE ASSEMBLY (S/S Sleeve)	816354-071	
19	WATER SLINGER	116368-000	

NOTES: (1) Bearing Assembly does not include Coverplate, Mechanical Seal Assembly, Ceramic Seat or Retainer Cup.
(2) Bearing Assembly Kit includes B/F Coverplate, Mechanical Seal Assembly, Ceramic Seat and Retainer Cup.
(3) 874112-000 Brg/Cap assy.Kit includes Brg/Cap Assy., "O" Ring, Oil Seal & Oil Wick.
(4) For TEFC or Explosion Proof Motors, contact the factory.

CIRCULATOR PARTS

MODEL NUMBER 1060 3D - SIZE 6 Serial No. 6910 & Later STANDARD BRONZE FITTED CONSTRUCTION

ITEM NO.	DESCRIPTION	PART NUMBER	ARMSTRONG BAR CODE
35	BEARING ASSEMBLY (1)	816366-041	
35	BEARING ASSEMBLY KIT C/W Seal Kit & Cover Plate (2)	816861-041	
10	BEARING BRACKET	816342-011	
4	BEARING CAP ASSEMBLY (3)	874112-000	
3	BEARING CAP CAPSCREWS 1/4-20X5/8	911117-105	
29	BODY	816646-041	
21	BODY CAPS. - 3/8-16X7/8	911121-107	
28	BODY GASKET	106592-000	
2	COUPLER ASSEMBLY (Flexible) 5/8X5/8	840482-013	
15	COUPLER GUARD	116114-000	
0	COUPLER INSERT	875000-898	
7	COUPLER KEY (Woodruff #9)	974515-100	
20	COVERPLATE (Cast Iron)	816346-011	
18	COVERPLATE CAPSCREWS 5/16-18X3/4	911119-106	
31	FLANGE -3" NPT - (Cast Iron)	933615-010	
32	FLANGE BOLTS - 5/8-11X2 1/2"	911125-100	
30	FLANGE GASKET	425605-106	
-	FLANGE NUTS - 5/8-11	913125-100	
25	IMPELLER (Brass) 7" Dia.	816647-041	
25	IMPELLER (Brass) 6 1/2" Dia.	816647-045	
25	IMPELLER (Brass) 6" Dia.	816647-049	
25	IMPELLER (Brass) 5 1/2" Dia.	816647-053	
25	IMPELLER (Brass) 5" Dia.	816647-057	
8	IMPELLER KEY (WOODRUFF #3)	974508-100	
27	IMPELLER NUT 7/16-20NF (Bronze)	116406-000	
26	IMPELLER WASHER	927412-700	
15	MECH. SEAL ASSY. (Brass Buna)	816707-001	
15	MECH. SEAL ASSY. (Brass Viton High Temp. 225F-275F)	816707-003	
14	OIL LEVEL WINDOW	116904-001	
9	OIL SLINGER	116369-000	
12	OIL WELL COVER ASSEMBLY	116361-000	
11	OIL WELL COVER GASKET	116400-000	
-	OIL WICKS (3/8X1/2)	816565-000	
1	RIGID MOUNT. MOT. ASSY. - 1PH/1HP/115/230V (4)	816676-062	
1	RIGID MOUNT. MOT. ASSY. - 1PH/1 1/2HP/115/230V (4)	816678-062	
1	RIGID MOUNT. MOT. ASSY. - 3PH/1HP/208/230/460V (4)	816676-069	
1	RIGID MOUNT. MOT. ASSY. - 3PH/1 1/2HP/208/230/460V (4)	816678-069	
1	RIGID MOUNT. MOT. ASSY. - 3PH/2HP/208/230/460V (4)	816681-069	
1	RIGID MOUNT. MOT. ASSY. - 3PH/1HP/575V (4)	811757-009	
1	RIGID MOUNT. MOT. ASSY. - 3PH/1 1/2HP/575V (4)	816685-068	
1	RIGID MOUNT. MOT. ASSY. - 3PH/2HP/575V (4)	816686-068	
1	RIGID MOUNT. MOT. ASSY. - 3PH/3HP/208/230/460V (4)	816711-069	
1	RIGID MOUNT. MOT. ASSY. - 3PH/3HP/575V (4)	816687-068	
17	RIGID MT. MTR. CAPSCREWS 3/8-16X7/8 (4 Req'd)	911121-107	
6	SHAFT & SLEEVE ASSEMBLY	816354-041	
6	SHAFT & SLEEVE ASSY. (S/S Sleeve)	816354-071	
19	WATER SLINGER	116368-000	

- NOTES:** (1) Bearing Assembly does not include Coverplate, Mechanical Seal Assembly, Ceramic Seat or Retainer Cup.
(2) Bearing Assembly Kit includes B/F Coverplate, Mechanical Seal Assembly, Ceramic Seat and Retainer Cup.
(3) 874112-000 Brg/Cap assy.Kit includes Brg/Cap Assy., "O" Ring, Oil Seal & Oil Wick.
(4) For TEFC or Explosion Proof Motors, contact the factory.

CIRCULATOR PARTS

MODEL NUMBER 1060 3D - SIZE 6 Serial No. 6910 & Later ALL BRONZE CONSTRUCTION

ITEM NO.	DESCRIPTION	PART NUMBER	ARMSTRONG BAR CODE
35	BEARING ASSEMBLY (1)	816366-041	
35	BEARING ASSEMBLY KIT C/W Seal Kit & Cover Plate (2)	816861-041	
10	BEARING BRACKET	816342-011	
4	BEARING CAP ASSEMBLY (3)	874112-000	
3	BEARING CAP CAPSCREWS 1/4-20X5/8	911117-105	
29	BODY	816646-011	
21	BODY CAPS. - 3/8-16X7/8	911121-107	
28	BODY GASKET	106592-000	
2	COUPLER ASSEMBLY (Flexible) 5/8X5/8	840482-013	
15	COUPLER GUARD	116114-000	
0	COUPLER INSERT	875000-898	
7	COUPLER KEY (Woodruff #9)	974515-100	
20	COVERPLATE (Bronze)	816346-041	
18	COVERPLATE CAPSCREWS 5/16-18X3/4	911119-106	
31	FLANGE -3" NPT - (Bronze)	106466-041	
32	FLANGE BOLTS - 5/8-11X2 1/2"	911125-100	
30	FLANGE GASKET	425605-106	
-	FLANGE NUTS - 5/8-11	913125-100	
25	IMPELLER (Brass) 7" Dia.	816647-041	
25	IMPELLER (Brass) 6 1/2" Dia.	816647-045	
25	IMPELLER (Brass) 6" Dia.	816647-049	
25	IMPELLER (Brass) 5 1/2" Dia.	816647-053	
25	IMPELLER (Brass) 5" Dia.	816647-057	
8	IMPELLER KEY (WOODRUFF #3)	974508-100	
27	IMPELLER NUT 7/16-20NF (Bronze)	116406-000	
26	IMPELLER WASHER	927412-700	
15	MECH. SEAL ASSY. (Brass Buna)	816707-001	
15	MECH. SEAL ASSY. (Brass Viton High Temp. 225F-275F)	816707-003	
14	OIL LEVEL WINDOW	116904-001	
9	OIL SLINGER	116369-000	
12	OIL WELL COVER ASSEMBLY	116361-000	
11	OIL WELL COVER GASKET	116400-000	
-	OIL WICKS (3/8X1/2)	816565-000	
1	RIGID MOUNT. MOT. ASSY. - 1PH/1HP/115/230V (4)	816676-062	
1	RIGID MOUNT. MOT. ASSY. - 1PH/1 1/2HP/115/230V (4)	816678-062	
1	RIGID MOUNT. MOT. ASSY. - 3PH/1HP/208/230/460V (4)	816676-069	
1	RIGID MOUNT. MOT. ASSY. - 3PH/1 1/2HP/208/230/460V (4)	816678-069	
1	RIGID MOUNT. MOT. ASSY. - 3PH/2HP/208/230/460V (4)	816681-069	
1	RIGID MOUNT. MOT. ASSY. - 3PH/1HP/575V (4)	811757-009	
1	RIGID MOUNT. MOT. ASSY. - 3PH/1 1/2HP/575V (4)	816685-068	
1	RIGID MOUNT. MOT. ASSY. - 3PH/2HP/575V (4)	816686-068	
1	RIGID MOUNT. MOT. ASSY. - 3PH/3HP/208/230/460V (4)	816711-069	
1	RIGID MOUNT. MOT. ASSY. - 3PH/3HP/575V (4)	816687-068	
17	RIGID MT. MTR. CAPSCREWS 3/8-16X7/8 (4 Req'd)	911121-107	
6	SHAFT & SLEEVE ASSEMBLY	816354-041	
6	SHAFT & SLEEVE ASSY. (S/S Sleeve)	816354-071	
19	WATER SLINGER	116368-000	

- NOTES:** (1) Bearing Assembly does not include Coverplate, Mechanical Seal Assembly, Ceramic Seat or Retainer Cup.
(2) Bearing Assembly Kit includes B/F Coverplate, Mechanical Seal Assembly, Ceramic Seat and Retainer Cup.
(3) 874112-000 Brg/Cap assy.Kit includes Brg/Cap Assy., "O" Ring, Oil Seal & Oil Wick.
(4) For TEFC or Explosion Proof Motors, contact the factory.

CIRCULATOR PARTS

MODEL NUMBER 1060 3D - SIZE 6 Serial No. 6910 & Later ALL IRON CONSTRUCTION

ITEM NO.	DESCRIPTION	PART NUMBER	ARMSTRONG BAR CODE
35	BEARING ASSEMBLY (1)	816366-071	
35	BEARING ASSEMBLY KIT C/W Seal Kit & Cover Plate (2)	816861-071	
10	BEARING BRACKET	816342-011	
4	BEARING CAP ASSEMBLY (3)	874112-000	
3	BEARING CAP CAPSCREWS 1/4-20X5/8	911117-105	
29	BODY	816646-011	
21	BODY CAPS. - 3/8-16X7/8	911121-107	
28	BODY GASKET	106592-000	
2	COUPLER ASSEMBLY (Flexible) 5/8X5/8	840482-013	
15	COUPLER GUARD	116114-000	
0	COUPLER INSERT	875000-898	
7	COUPLER KEY (Woodruff #9)	974515-100	
20	COVERPLATE (Cast Iron)	816346-011	
18	COVERPLATE CAPSCREWS 5/16-18X3/4	911119-106	
31	FLANGE -3" NPT - (Cast Iron)	933615-010	
32	FLANGE BOLTS - 5/8-11X2 1/2"	911125-100	
30	FLANGE GASKET	425605-106	
-	FLANGE NUTS - 5/8-11	913125-100	
25	IMPELLER (Steel) 7" Dia.	816647-011	
25	IMPELLER (Steel) 6 1/2" Dia.	816647-015	
25	IMPELLER (Steel) 6" Dia.	816647-019	
25	IMPELLER (Steel) 5 1/2" Dia.	816647-023	
25	IMPELLER (Steel) 5" Dia.	816647-027	
8	IMPELLER KEY (WOODRUFF #3)	974508-100	
27	IMPELLER NUT 7/16-20NF (Steel)	913173-100	
26	IMPELLER WASHER	927412-700	
15	MECH. SEAL ASSY. (Steel Buna)	816707-002	
15	MECH. SEAL ASSY. (Steel Viton High Temp. 225F-275F)	816707-004	
14	OIL LEVEL WINDOW	116904-001	
9	OIL SLINGER	116369-000	
12	OIL WELL COVER ASSEMBLY	116361-000	
11	OIL WELL COVER GASKET	116400-000	
-	OIL WICKS (3/8X1/2)	816565-000	
1	RIGID MOUNT. MOT. ASSY. - 1PH/1HP/115/230V (4)	816676-062	
1	RIGID MOUNT. MOT. ASSY. - 1PH/1 1/2HP/115/230V (4)	816678-062	
1	RIGID MOUNT. MOT. ASSY. - 3PH/1HP/208/230/460V (4)	816676-069	
1	RIGID MOUNT. MOT. ASSY. - 3PH/1 1/2HP/208/230/460V (4)	816678-069	
1	RIGID MOUNT. MOT. ASSY. - 3PH/2HP/208/230/460V (4)	816681-069	
1	RIGID MOUNT. MOT. ASSY. - 3PH/1HP/575V (4)	811757-009	
1	RIGID MOUNT. MOT. ASSY. - 3PH/1 1/2HP/575V (4)	816685-068	
1	RIGID MOUNT. MOT. ASSY. - 3PH/2HP/575V (4)	816686-068	
1	RIGID MOUNT. MOT. ASSY. - 3PH/3HP/208/230/460V (4)	816711-069	
1	RIGID MOUNT. MOT. ASSY. - 3PH/3HP/575V (4)	816687-068	
17	RIGID MT. MTR. CAPSCREWS 3/8-16X7/8 (4 Req'd)	911121-107	
6	SHAFT & SLEEVE ASSEMBLY (S/S Sleeve)	816354-071	
19	WATER SLINGER	116368-000	

NOTES: (1) Bearing Assembly does not include Coverplate, Mechanical Seal Assembly, Ceramic Seat or Retainer Cup.
 (2) Bearing Assembly Kit includes B/F Coverplate, Mechanical Seal Assembly, Ceramic Seat and Retainer Cup.
 (3) 874112-000 Brg/Cap assy.Kit includes Brg/Cap Assy., "O" Ring, Oil Seal & Oil Wick.
 (4) For TEFC or Explosion Proof Motors, contact the factory.