

QUICK REFERENCE

Stock Sub-FHP Gearmotors

AC Single & Three Phase

Single Phase 115V
12-100 In-Lbs
Output Torque
Page 166

BODINE/BISON/DAYTON
DIRECT INTERCHANGE

DC SCR & Low Voltage

DC SCR 90 & 180V
10-100 In-Lbs
Output Torque
Low Voltage (12V)
36-100 In-Lbs torque
Page 156



**Parallel Shaft
PZ Series
Gearmotors**



**P240 & P300 Series
Gearmotors**

Single Phase 115/230V
43-391 In-Lbs
Output Torque
Page 167

BISON/DAYTON
DIRECT INTERCHANGE

DC SCR 90 & 180V
27-353 In-Lbs
Output Torque
Low Voltage (12V)
113-353 In-Lbs torque
Page 157



**OS300 Series
Gearmotors**

DC SCR 90V
and
Low Voltage (12V)
Output Torque
130-268 In-Lbs
Page 158



**PE350 Series
Gearmotors**

Single Phase 115/230V
25-341 In-Lbs
Output Torque
Three Phase 230/460V
55-320 In-Lbs
Output Torque
Page 168

**BODINE
DIRECT
INTERCHANGE**

DC SCR 90 & 180V
25-371 In-Lbs
Output Torque
Low Voltage (12V)
155-341 In-Lbs torque
Page 159



**P1100 Series
Gearmotors**

Single Phase 115/230V
70-1105 In-Lbs
Output Torque
Three Phase 230/460V
70-1105 In-Lbs
Output Torque
Page 169

BISON/DAYTON
DIRECT INTERCHANGE

DC SCR 90V
105-1112 In-Lbs
Output Torque
Low Voltage (12V)
320-1087 In-Lbs torque
Page 160



**Right-Angle
Worm Type
10 & 13 Series
Gearmotors**

Single Phase 115/230V
14-113 In-Lbs
Output Torque
Page 170

BODINE/DAYTON
DIRECT INTERCHANGE

DC SCR 90 & 180V
5-135 In-Lbs
Output Torque
Low Voltage (12V)
25-135 In-Lbs torque
Page 161



**Bravo Right
Angle
Worm Type
12 Series
Gearmotors**

DC SCR 90V
and
Low Voltage (12V)
Output Torque
46-134 In-Lbs
Page 162

QUICK REFERENCE

Stock Sub-FHP IP55 WASHGUARD™ Gearmotors



**P300 Series
Gearmotors**

DC SCR 90V
and
Low Voltage (12V)
Output Torque
44-353 In-Lbs
Page 163



**PE350 Series
Gearmotors**

DC SCR 90V
and
Low Voltage (12V)
Output Torque
25-341 In-Lbs
Page 164



**Right-Angle
13 Series
Gearmotors**

DC SCR 90V
and
Low Voltage (12V)
Output Torque
50-135 In-Lbs
Page 165

Stock Sub-FHP Three Phase Inverter Rated Gearmotors



Includes gearmotor
series PZ, P240,
PE350 and 13 series
right-angle

Three phase 230V
12-391 In-Lbs
Output Torque
Page 172



SUB-FHP DC GEARMOTORS PARALLEL SHAFT GEARMOTORS

**SCR RATED:
10-100 In-Lbs Torque**

**LOW VOLTAGE:
36-100 In-Lbs Torque**

Electrical Specifications:

SCR Rated Gearmotors

Totally enclosed, permanent magnet DC gearmotors, performance matched for continuous duty service over a 60:1 speed range. All have constant torque throughout the range when powered by a full-wave unfiltered SCR-type adjustable speed control having a typical form factor of 1.3 to 1.4.

Low Voltage Gearmotors

Totally enclosed, permanent magnet DC gearmotors, performance matched for continuous duty. Motors are designed for battery power or can be used with a low voltage controller with form factor up to 1.05.

Mechanical Specifications:

Precision machined in-line steel gears, with a first stage steel helical gear followed by spur-type gears. Lubrication is permanent semi-fluid grease, reducing possibility of leakage. Output shafts have needle bearings for high load capacities. Shafts are hardened steel.

Conduit box not included with motor. Optional conduit box and PZ gearmotor mounting bracket shown on page 171.

Application Notes:

These gearmotors are designed for mounting at any angle, but motor below the reducer should be avoided to prevent leakage of lubricant into the motor should the motor shaft seal fail.

The motor's stall torque could exceed recommended full load torques. If this service is anticipated, a current limiting device should be used. This issue is even more critical for low voltage motors, typically no controller is used since motor connected directly to battery, so some type of current limit or fusing should be considered.

Overhung load capacities shown are at center of output shaft.

Model PZ gearmotors have the same mounting dimensions as Bodine model D and Z, Baldor/Boehm, Bison 100 gearmotors, and a number of Dayton gearmotors.

For additional information, see Bulletin 1830.



PZ SERIES DC • SCR RATED PARALLEL SHAFT • TENV • 1.0 SERVICE FACTOR

Output RPM	F.L. Torque (Lb.In.)	Input HP	Catalogue Number	List Price▲	Gearmotor Type & Frame	Ratio to 1	Arm. Volts DC	F.L. Amps DC	Over-hung Load (Lb.)	DIMENSIONS			
										P	X	XL	XH
4	100	1/40	M1115002	\$589	PZ5-30A	450	90	0.46	155	3.00	3.25	9.28	7.72
4	100	1/40	M1125046	549	PZ5-30A	450	180	0.19	155	3.00	3.25	9.30	7.74
10	100	1/20	M1115001	519	PZ4-30E	180	90	0.54	155	3.00	3.25	9.28	7.72
10	100	1/20	M1125047	519	PZ4-30A	180	180	0.31	155	3.00	3.25	9.30	7.74
20	100	1/20	M1115000	519	PZ4-30E	90	90	0.54	155	3.00	3.25	9.28	7.72
20	100	1/20	M1125048	519	PZ4-30A	90	180	0.31	155	3.00	3.25	9.30	7.74
30	100	1/17	M1125002	472	PZ3-30B	60	90	0.80	155	3.00	2.68	8.74	7.18
30	100	1/17	M1125037	472	PZ3-30B	60	180	0.36	155	3.00	2.68	8.74	7.18
60	56	1/17	M1125003	472	PZ3-30B	30	90	0.80	171	3.00	2.68	8.74	7.18
60	56	1/17	M1125036	472	PZ3-30B	30	180	0.36	171	3.00	2.68	8.74	7.18
100	36	1/17	M1125004	472	PZ3-30B	18	90	0.80	171	3.00	2.68	8.74	7.18
100	36	1/17	M1125035	472	PZ3-30B	18	180	0.36	171	3.00	2.68	8.74	7.18
150	24	1/17	M1125005	472	PZ2-30B	12	90	0.80	180	3.00	2.40	8.46	6.90
150	24	1/17	M1125034	472	PZ2-30B	12	180	0.36	180	3.00	2.40	8.46	6.90
300	12	1/17	M1125006	472	PZ2-30B	6	90	0.80	180	3.00	2.40	8.46	6.90
300	12	1/17	M1125033	472	PZ2-30B	6	180	0.36	180	3.00	2.40	8.46	6.90

▲ Use "A" discount symbol.

PZ SERIES DC • LOW VOLTAGE (12V) PARALLEL SHAFT • TENV • 1.0 SERVICE FACTOR

Output RPM	F.L. Torque (Lb.In.)	Input HP	Catalogue Number	List Price▲	Gearmotor Type & Frame	Ratio to 1	Arm. Volts DC	F.L. Amps DC	Over-hung Load (Lb.)	DIMENSIONS			
										P	X	XL	XH
10	100	1/20	M1125213	\$508	PZ4-30	180	12	2.7	155	3.00	3.25	9.28	7.72
30	100	1/17	M1125214	540	PZ3-30	60	12	5.2	155	3.00	2.68	8.74	7.18
55	56	1/17	M1125215	540	PZ3-30	30	12	5.6	171	3.00	2.68	8.74	7.18
90	36	1/17	M1125216	540	PZ3-30	18	12	5.8	171	3.00	2.68	8.74	7.18

▲ Use "A" discount symbol.

PZ SERIES - DC

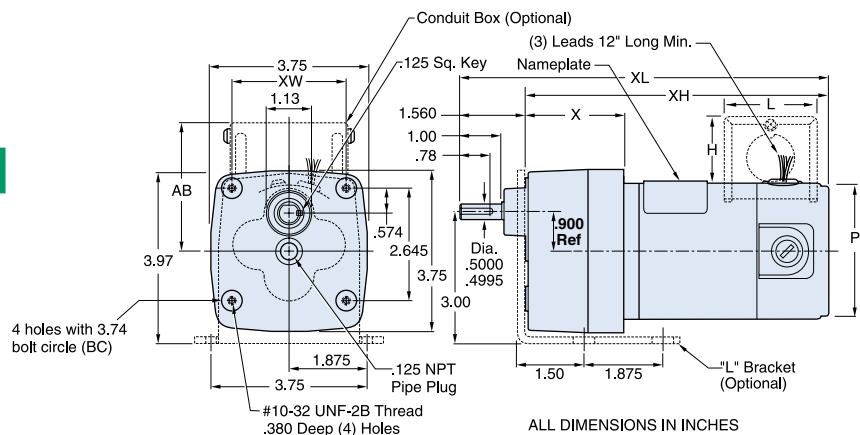

**BODINE/BISON/DAYTON
DIRECT INTERCHANGE**

QUICK REFERENCE

GEARMOTOR CROSS REFERENCE Page 194
"L" BRACKET AND CONDUIT BOX 171
SPEEDMASTER® CONTROLS 102

CONDUIT BOX DIMENSIONS (IN.)

FRAME	XW	AB	H	L
30/31	2.63	3.47	1.90	3.13

SUB-FHP DC GEARMOTORS PARALLEL SHAFT GEARMOTORS



**SCR RATED:
27-353 In-Lbs Torque**

**LOW VOLTAGE:
113-353 In-Lbs Torque**

Electrical Specifications:

SCR Rated Gearmotors

Totally enclosed, permanent magnet DC gearmotors, performance matched for continuous duty service over a 60:1 speed range. All have constant torque throughout the range when powered by a full-wave unfiltered SCR-type adjustable speed control having a typical form factor of 1.3 to 1.4.



Low Voltage Gearmotors

Totally enclosed, permanent magnet DC gearmotors, performance matched for continuous duty. Motors are designed for battery power or can be used with a low voltage controller with form factor up to 1.05.

Mechanical Specifications:

Precision machined in-line steel gears, with a first stage steel helical gear followed by spur-type gears. Lubrication is permanent semi-fluid grease, reducing possibility of leakage. Output shafts have needle bearings for high load capacities. Shafts are hardened steel.

Conduit box *not* included with motor. Optional conduit box shown on page 171.

Application Notes:

These gearmotors are designed for mounting at any angle, but shaft up with motor below should be avoided to prevent leakage of lubricant into the motor should the motor's shaft seal fail.

Overhung load capacities shown are at center of output shaft.

The motor's stall torque exceeds recommended full load torques. A current limiting device such as an SCR control should be used to prevent damage. Model 300 gearmotors have the same mounting dimensions as Bison's 300 and many Dayton gearmotors.

For additional information, see Bulletin 1830.

**BISON/DAYTON
DIRECT INTERCHANGE**

P300 SERIES DC • SCR RATED PARALLEL SHAFT • TENV • 1.0 SERVICE FACTOR

Output RPM	F.L. Torque (Lb.In.)	Input HP	Catalogue Number	List Price▲	Gearmotor Type & Frame	Ratio to 1	Arm. Volts DC	F.L. Amps. DC	Over-hung Load (Lb.)	P	X	XL	XH
										DIMENSIONS Inches			
5	353	1/20	M1115024	\$680	P303-30E	336	90	0.54	565	3.00	3.54	10.07	8.57
9	268	1/20	M1115025	680	P303-30E	216	90	0.54	474	3.00	3.54	10.07	8.57
18	150	1/20	M1115026	680	P303-30E	103	90	0.54	385	3.00	3.54	10.07	8.57
20	140	1/20	M1125092	680	P303-31E	90	180	0.31	370	3.11	3.54	10.07	8.57
24	280	1/8	M1125069	680	P303-31E	76	90	1.30	353	3.00	3.54	11.54	10.04
31	220	1/8	M1125070	680	P303-31E	58	90	1.30	327	3.00	3.54	11.54	10.04
31	220	1/8	M1125038	680	P303-31E	58	180	0.66	327	3.00	3.54	11.54	10.04
34	82	1/20	M1115027	680	P303-30E	52	90	0.54	318	3.00	3.54	10.07	8.57
53	130	1/8	M1125071	680	P302-31E	33	90	1.30	277	3.00	3.54	11.54	10.04
53	130	1/8	M1125039	680	P302-31E	33	180	0.66	277	3.00	3.54	11.54	10.04
53	55	1/20	M1115028	663	P302-30E	33	90	0.54	281	3.00	3.54	10.07	8.57
61	113	1/8	M1125072	663	P302-31E	29	90	1.30	267	3.11	3.54	11.54	10.04
61	45	1/20	M1125093	663	P302-31E	29	180	0.31	267	3.00	3.54	10.07	8.57
94	77	1/8	M1125073	663	P302-31E	19	90	1.30	236	3.00	3.54	11.54	10.04
94	77	1/8	M1125040	663	P302-31E	19	180	0.66	236	3.00	3.54	11.54	10.04
109	27	1/20	M1115029	663	P302-30E	16	90	0.54	224	3.00	3.54	10.07	8.57
109	27	1/20	M1125094	663	P302-30E	16	180	0.31	224	3.11	3.54	10.07	8.57
170	43	1/8	M1125074	663	P302-31E	11	90	1.30	197	3.00	3.54	11.54	10.04
170	43	1/8	M1125041	663	P302-31E	10	180	0.66	196	3.00	3.54	11.54	10.04

▲ Use "A" discount symbol.

P300 SERIES DC • LOW VOLTAGE (12V) PARALLEL SHAFT • TENV • 1.0 SERVICE FACTOR

Output RPM	F.L. Torque (Lb.In.)	Input HP	Catalogue Number	List Price▲	Gearmotor Type & Frame	Ratio to 1	Arm. Volts DC	F.L. Amps. DC	Over-hung Load (Lb.)	P	X	XL	XH
										DIMENSIONS Inches			
5	353	1/20	M1125217	\$673	P303-30	336	12	5.6	565	3.00	3.85	10.07	8.57
31	220	1/8	M1125218	691	P303-31	58	12	10.6	327	3.00	3.54	11.54	10.04
53	130	1/8	M1125219	633	P302-30	35	12	10.3	277	3.00	3.23	11.54	10.04
61	113	1/8	M1125220	633	P302-30	29	12	10.4	267	3.00	3.23	11.54	10.04

▲ Use "A" discount symbol.

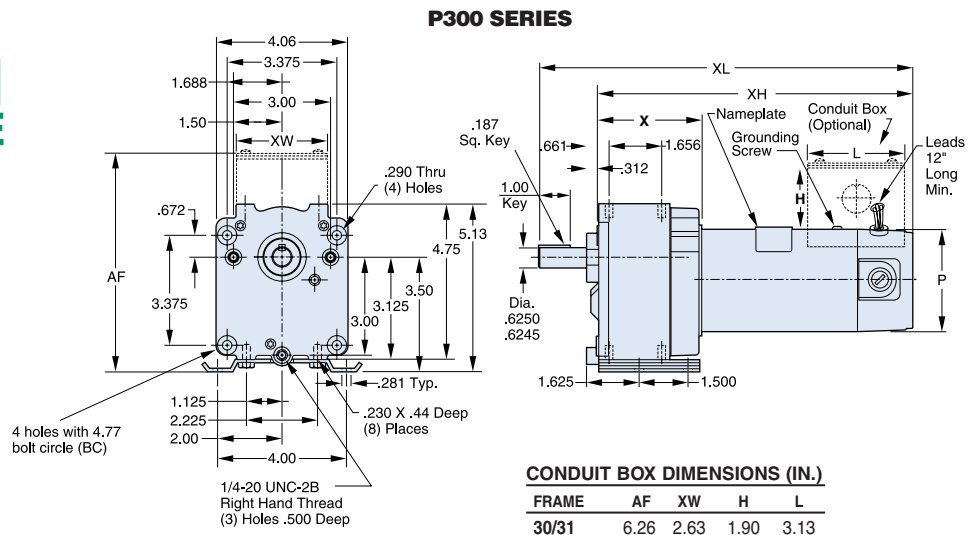



SUB-FHP DC GEARMOTORS

OFF-SET SHAFT GEARMOTORS

SCR RATED:
130-268 In-Lbs Torque

LOW VOLTAGE:
130-268 In-Lbs Torque

Electrical Specifications:
SCR Rated Gearmotors

Totally enclosed, permanent magnet DC gearmotors, performance matched for continuous duty service over a 60:1 speed range. All have constant torque throughout the range when powered by a full-wave unfiltered SCR-type adjustable speed control having a typical form factor of 1.3 to 1.4.



Low Voltage Gearmotors

Totally enclosed, permanent magnet DC gearmotors, performance matched for continuous duty. Motors are designed for battery power or can be used with a low voltage controller with form factor up to 1.05.

Mechanical Specifications:

Precision machined steel gears, with a first stage steel helical gear followed by spur-type gears. Lubrication is permanent semi-fluid grease, reducing possibility of leakage. Output shafts have needle bearings for high load capacities. Shafts are hardened steel.

Conduit box *not* included with motor. Optional conduit box shown on page 171.

Application Notes:

These gearmotors are designed for mounting at any angle, but shaft up with motor below should be avoided to prevent leakage of lubricant into the motor should the motor's shaft seal fail. Overhung load capacities shown are at center of output shaft. The motor's stall torque exceeds recommended full load torques. A current limiting device such as an SCR control should be used to prevent damage.

OS300 SERIES DC • SCR RATED OFF-SET SHAFT • TENV • 1.0 SERVICE FACTOR

Output RPM	F.L. Torque (Lb.In.)	Input HP	Catalog Number	List Price▲	Gearmotor Type & Frame	Ratio	Arm Volts DC	F.L. Amps DC	Overhung Load Lbs.	P	DIMENSIONS Inches		
											X	XL	XH
9	268	1/20	M1125251	\$440	OS303-30	210	90	.54	474	3.00	2.81	4.50	8.52
19	150	1/20	M1125250	486	OS303-30	103	90	.56	385	3.00	2.81	4.50	8.52
24	280	1/8	M1125249	500	OS303-30	76	90	1.3	353	3.00	2.81	6.42	10.45
31	220	1/8	M1125248	505	OS303-30	58	90	1.4	327	3.00	2.81	6.42	10.45
51	130	1/8	M1125247	520	OS303-30	35	90	1.4	277	3.00	2.81	6.42	10.45

OS300 SERIES DC • LOW VOLTAGE (12V) OFF-SET SHAFT • TENV • 1.0 SERVICE FACTOR

Output RPM	F.L. Torque (Lb.In.)	Input HP	Catalog Number	List Price▲	Gearmotor Type & Frame	Ratio	Arm Volts DC	F.L. Amps DC	Overhung Load Lbs.	P	DIMENSIONS Inches		
											X	XL	XH
9	268	1/20	M1125256	\$451	OS303-30	210	12	4.5	474	3.00	2.81	4.50	8.52
18	150	1/20	M1125255	480	OS303-30	103	12	5.0	385	3.00	2.081	4.50	8.52
24	280	1/8	M1125254	482	OS303-30	76	12	10.6	353	3.00	2.81	6.42	10.45
31	220	1/8	M1125253	485	OS303-30	58	12	10.6	327	3.00	2.81	6.42	10.45
51	130	1/8	M1125252	502	OS303-30	35	12	10.3	277	3.00	2.81	6.42	10.45

▲ Use "A" discount symbol.

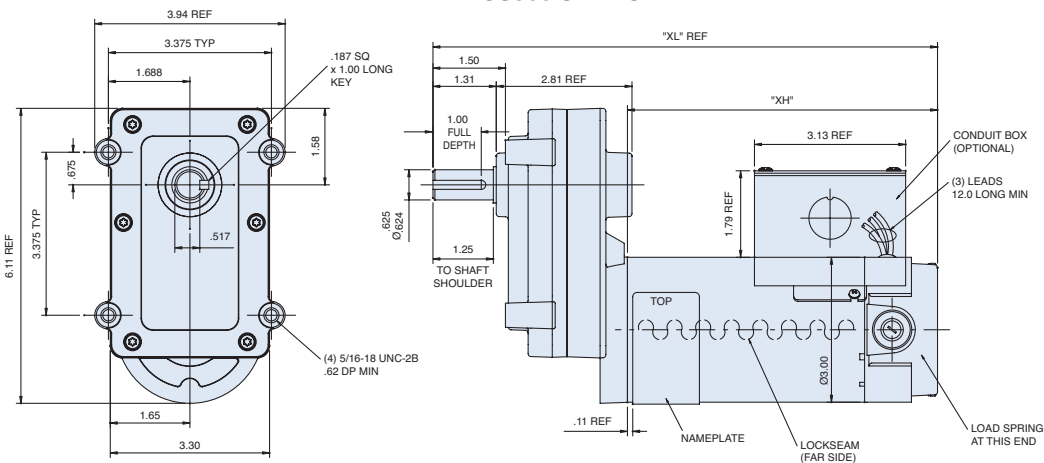

ALL DIMENSIONS IN INCHES

Catalog numbers in blue are NEW items.

**SCR RATED:
25-371 In-Lbs Torque**

**LOW VOLTAGE:
155-341 In-Lbs Torque**

**Electrical Specifications:
SCR Rated Gearmotors**

Totally enclosed, permanent magnet DC gearmotors, performance matched for continuous duty service over a 60:1 speed range. All have constant torque throughout the range when powered by a full-wave unfiltered SCR-type adjustable speed control having a typical form factor of 1.3 to 1.4.



Low Voltage Gearmotors

Totally enclosed, permanent magnet DC gearmotors, performance matched for continuous duty. Motors are designed for battery power or can be used with a low voltage controller with form factor up to 1.05.

Mechanical Specifications:

Gearbox has rugged aluminum die cast housing, for maximum gear and bearing support. Precision machined gearing, hardened for maximum load capability. All gearing designed and rated to AGMA Class 9 standards and to withstand momentary shock overload of 200%. Oversized output bearings for greater overhung load capacity and longer life. High-carbon alloy output shaft provides maximum strength and rigidity. All needle bearing journals are precision-ground after heat treating, to provide maximum finish and fit. Heavy-duty industrial oil seals help keep lubricant in and dirt out. Gears and bearings are splash lubricated with permanent, heavy-duty gear oil.

Conduit box not included with motor. Optional conduit box shown on page 171.

Application Notes:

These gearmotors are designed for mounting at any angle, but shaft up with motor below should be avoided to prevent leakage of lubricant into the motor should the motor's shaft seal fail.

Overhung load capacities shown are at center of output shaft.

The motor's stall torque exceeds recommended full load torques. A current limiting device such as an SCR control should be used to prevent damage.

Model PE350 gearmotors have the same mounting dimensions as Bodine's "E" box and many Baldor gearmotors.

**PE350 SERIES DC • SCR RATED
PARALLEL SHAFT • TENV • 1.0 SERVICE FACTOR**

Output RPM	F.L. Torque (Lb.In.)	Input HP	Catalogue Number	List Price▲	Type & Frame	Ratio to 1	Arm Volts DC	F.L. Amps DC	Overhung Load (lbs.)	DIMENSIONS XL Inches	XH Inches
7	330	1/8	M1135106	\$666	P353-34	336	90	0.70	565	11.31	9.31
7	330	1/8	M1135139	666	P353-34	336	180	0.35	565	11.31	9.31
14	341	1/8	M1135107	652	P353-34	180	90	1.00	465	11.31	9.31
14	341	1/8	M1135140	652	P353-34	180	180	0.50	465	11.31	9.31
21	371	1/4	M1135117	668	P353-34	124	90	1.10	413	13.31	11.31
21	371	1/4	M1135141	668	P353-34	124	180	0.55	413	13.31	11.31
27	305	1/4	M1135115	673	P353-34	91	90	1.50	374	13.31	11.31
27	305	1/4	M1135142	673	P353-34	91	180	0.75	374	13.31	11.31
42	280	1/4	M1135108	671	P353-34	58	90	2.30	327	13.31	11.31
42	280	1/4	M1135143	671	P353-34	58	180	1.20	327	13.31	11.31
50	250	1/4	M1135109	688	P353-34	50	90	2.30	315	13.31	11.31
50	250	1/4	M1135144	688	P353-34	50	180	1.20	315	13.31	11.31
62	220	1/4	M1135110	677	P353-34	43	90	2.30	303	13.31	11.31
62	220	1/4	M1135145	677	P353-34	43	180	1.20	303	13.31	11.31
83	155	1/4	M1135114	631	P352-34	29	90	2.30	267	13.31	11.31
83	155	1/4	M1135146	631	P352-34	29	180	1.20	267	13.31	11.31
125	100	1/4	M1135111	637	P352-34	23	90	2.00	256	13.31	11.31
125	100	1/4	M1135147	637	P352-34	23	180	1.00	256	13.31	11.31
165	70	1/4	M1135112	637	P352-34	15	90	2.00	232	13.31	11.31
165	70	1/4	M1135148	637	P352-34	15	180	1.00	232	13.31	11.31
250	45	1/4	M1135116	627	P352-34	10	90	2.00	201	13.31	11.31
250	45	1/4	M1135149	627	P352-34	10	180	1.00	201	13.31	11.31
500	25	1/4	M1135113	639	P352-34	5	90	2.00	194	13.31	11.31
500	25	1/4	M1135150	639	P352-34	5	180	1.00	194	13.31	11.31

▲ Use "A" discount symbol for all gearmotors.

**PE350 SERIES DC • LOW VOLTAGE (12V)
PARALLEL SHAFT • TENV • 1.0 SERVICE FACTOR**

Output RPM	F.L. Torque (Lb.In.)	Input HP	Catalogue Number	List Price▲	Type & Frame	Ratio to 1	Arm Volts DC	F.L. Amps DC	Overhung Load (lbs.)	DIMENSIONS XL Inches	XH Inches
14	341	1/8	M1135243	\$678	P353-34	180	12	8.7	465	11.05	9.05
42	280	1/4	M1135244	710	P353-34	58	12	21.0	327	13.31	11.31
62	220	1/4	M1135245	710	P353-34	43	12	21.0	303	13.31	11.31
83	155	1/4	M1135246	673	P352-34	29	12	21.0	267	13.31	11.31

▲ Use "A" discount symbol for all gearmotors.

**BODINE
DIRECT
INTERCHANGE**

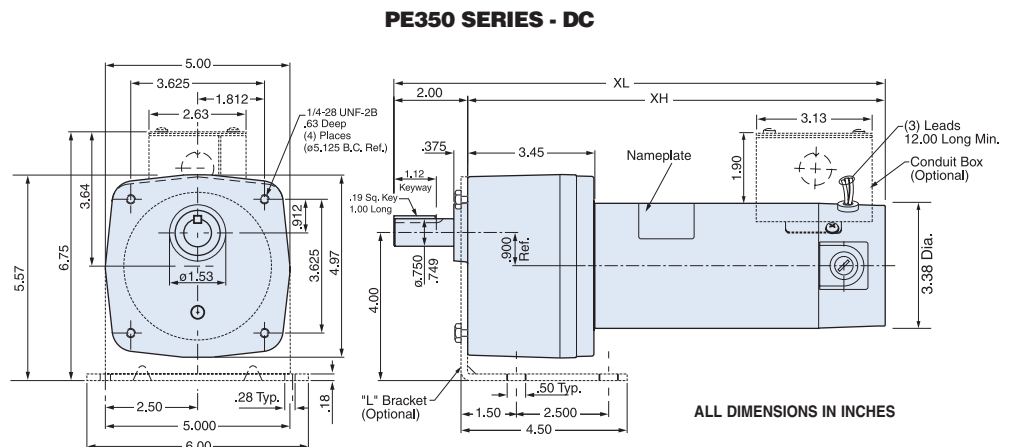



FHP DC GEARMOTORS

PARALLEL SHAFT GEARMOTORS

SCR RATED:
105-1112 In-Lbs Torque
LOW VOLTAGE:
320-1087 In-Lbs Torque

Electrical Specifications:

SCR Rated Gearmotors

SCR rated, permanent magnet DC gearmotors. Totally enclosed for continuous duty, general purpose applications. All have constant torque throughout the 60:1 speed range, when powered by a full-wave, unfiltered SCR-type adjustable speed control having a typical form factor of 1.3 to 1.4.



Low Voltage Gearmotors

Totally enclosed, permanent magnet DC gearmotors, performance matched for continuous duty. Motors are designed for battery power or can be used with a low voltage controller with form factor up to 1.05.

Mechanical Specifications:

Gearbox has rugged aluminum die cast housing, for maximum gear and bearing support. Precision machined gearing, hardened for maximum load capability. All gearing designed and rated to AGMA Class 9 standards and to withstand momentary shock overload of 200%. Oversized output bearings for greater overhung load capacity and longer life. High-carbon alloy output shaft provides maximum strength and rigidity. All needle bearing journals are precision-ground after heat treating, to provide maximum finish and fit. Heavy-duty industrial oil seals help keep lubricant in and dirt out. Gears and bearings are splash lubricated with permanent, heavy-duty gear oil. **Conduit box is included as standard.**

Application Notes:

These gearmotors are designed for mounting at any angle, but shaft-up with motor below gearhead is not recommended. Overhung load capacities shown are at center of output shaft. P1100 DC gearmotors have the same mounting dimensions as Bison 483 gearmotors and many Dayton gearmotors. The motor's stall torque exceeds recommended full load torques. A current limiting device such as an SCR control should be used to prevent damage. For additional information, see Bulletin 1830.

P1100 SERIES DC • SCR RATED FRACTIONAL HP • PARALLEL SHAFT • TOTALLY ENCLOSED 1.0 SERVICE FACTOR

Output RPM	F.L. Torque (Lb.In.)	Input HP	Catalogue Number	List Price▲	Type & Frame	Ratio to 1	Arm Volts DC	F.L. Amps DC	Overhung Load (lbs.)	DIMENSIONS XL XH Inches	
8	1087	¼	108700	\$1444	P1103-48	212	90	2.7	700	14.24	12.74
12	1030	¼	108701	1444	P1103-48	143	90	2.7	700	14.24	12.74
18	750	¼	108702	1441	P1103-48	95	90	2.7	700	14.24	12.74
42	353	¼	108703	1387	P1102-48	42	90	2.7	650	14.24	12.74
60	238	¼	108704	1387	P1102-48	29	90	2.7	625	14.24	12.74
92	160	¼	108705	1387	P1102-48	19	90	2.7	575	14.24	12.74
135	105	¼	108706	1387	P1102-48	13	90	2.7	525	14.24	12.74
18	1112	½	108707**	1490	P1103-48	95	90	5.0	700	16.49	14.99
33	822	½	108708**	1490	P1103-48	53	90	5.0	650	16.49	14.99
42	705	½	108709**	1432	P1102-48	42	90	5.0	650	16.49	14.99
60	476	½	108710**	1433	P1102-48	29	90	5.0	625	16.49	14.99
92	320	½	108711**	1433	P1102-48	19	90	5.0	575	16.49	14.99
135	210	½	108712**	1433	P1102-48	13	90	5.0	525	16.49	14.99

▲ Use "A" discount symbol.
 ** TEFC enclosure.

P1100 SERIES DC • LOW VOLTAGE (12V) FRACTIONAL HP • PARALLEL SHAFT • TOTALLY ENCLOSED 1.0 SERVICE FACTOR

Output RPM	F.L. Torque (Lb.In.)	Input HP	Catalogue Number	List Price▲	Type & Frame	Ratio to 1	Arm Volts DC	F.L. Amps DC	Overhung Load (lbs.)	DIMENSIONS XL XH Inches	
8	1087	¼	108729	\$1155	P1103-48	212	12	21.0	700	13.74	12.24
60	238	¼	108730	1130	P1102-48	29	12	21.0	625	13.74	12.24
42	705	½	108731**	1225	P1102-48	42	12	40.0	650	15.99	14.49
92	320	½	108732**	1225	P1102-48	19	12	40.0	575	15.99	14.49

▲ Use "A" discount symbol.
 ** TEFC enclosure.

**BISON/DAYTON
 DIRECT INTERCHANGE**

P1100 SERIES - DC

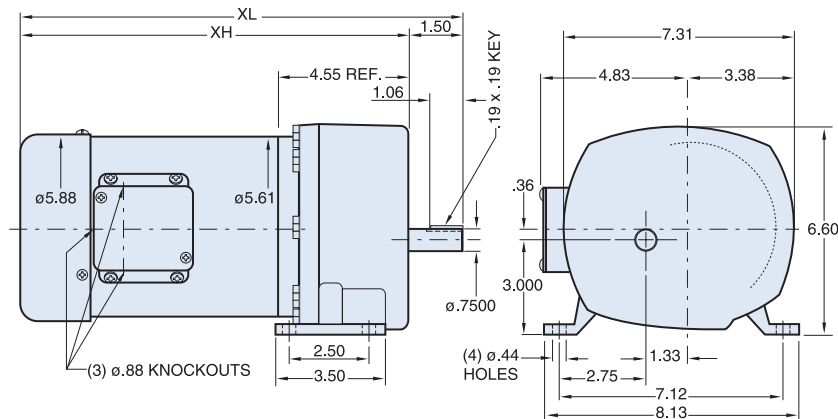

ALL DIMENSIONS IN INCHES

**SCR RATED:
5-135 In-Lbs Torque**

**LOW VOLTAGE:
25-135 In-Lbs Torque**

Electrical Specifications:

SCR Rated Gearmotors

Totally enclosed right-angle gearmotors, performance matched for continuous service over a 60:1 speed range. All have constant torque throughout the range when powered by a full-wave, unfiltered SCR-type 115 volt input adjustable speed control having a typical form factor of 1.3 to 1.4. Also available as factory options are motors for low voltage input and with double output shafts.



Low Voltage Gearmotors

Totally enclosed, permanent magnet DC gearmotors, performance matched for continuous duty. Motors are designed for battery power or can be used with a low voltage controller with form factor up to 1.05.

Mechanical Specifications:

This worm-type right-angle gearing features hardened, steel worm with bronze worm wheel for long life and quiet operation. Precision machined aluminum housings are used. Gearbox has all ball bearings. The housing is sealed and lubrication is permanent with an oil bath. The output shaft is field interchangeable from left hand style to right hand style by reassembly.

Application Notes:

For optimum seal life, these right-angle gearmotors have a lubrication breather positioned for horizontal mounting. For other mountings, the breather-plug must be reoriented by using a 90/1/8" NPT taper pipe elbow (see drawing). Elbow not available from LEESON. Vent plug is available (Part #M1900177_01). However, the motor portion of the gearmotor should never be mounted below the gearhead.

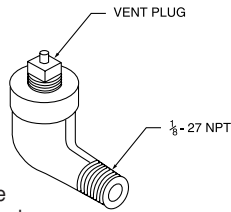

Overhung load capacities shown are at center of output shaft. **Conduit box not supplied with motor.** See page 171 for optional conduit box and optional base kit.

See page 205 for cross reference data between LEESON and other gearmotors.

For additional information on LEESON gearmotors, see Bulletin 1830.

**RIGHT-ANGLE DC • SCR RATED
TENV • 1.0 SERVICE FACTOR**

Output RPM	F.L. Torque (In.-Lbs.)	Input HP	Catalogue Number	List Price▲	Gearmotor Type & Frame	Ratio to 1	Arm Volts DC	Full Load Amps. DC	Over-hung Load (lbs.)	DIMENSIONS				
										P	PB	X Inches	XL	XH
42	22	1/17	M1115018	\$559	10F60-24D	60	90	0.68	185	2.50	3.00	3.60	8.79	5.19
62	19	1/17	M1115019	559	10F40-24D	40	90	0.68	185	2.50	3.00	3.60	8.79	5.19
125	16	1/17	M1115020	559	10F20-24D	20	90	0.68	185	2.50	3.00	3.60	8.79	5.19
250	10	1/17	M1115021	559	10F10-24D	10	90	0.68	185	2.50	3.00	3.60	8.79	5.19
500	5	1/17	M1115022	559	10F05-24D	5	90	0.68	185	2.50	3.00	3.60	8.79	5.19
42	30	1/12	M1135053	559	13F60-34A	60	180	0.53	235	3.38	4.00	4.50	9.64	5.14
62	35	1/12	M1135054	559	13F40-34A	40	180	0.53	235	3.38	4.00	4.50	9.64	5.14
125	18	1/12	M1135055	559	13F20-34A	20	180	0.53	235	3.38	4.00	4.50	9.64	5.14
250	10	1/12	M1135056	559	13F10-34A	10	180	0.53	235	3.38	4.00	4.50	9.64	5.14
500	5	1/12	M1135057	559	13F05-34A	5	180	0.53	235	3.38	4.00	4.50	9.64	5.14
42	80	1/8	M1135069	612	13F60-34C	60	90	1.40	235	3.38	4.00	4.50	10.64	6.14
62	70	1/8	M1135038	612	13F40-34C	40	90	1.40	235	3.38	4.00	4.50	10.64	6.14
62	70	1/8	M1135058	612	13F40-34C	40	180	0.70	235	3.38	4.00	4.50	10.64	6.14
125	45	1/8	M1135039	612	13F20-34C	20	90	1.40	235	3.38	4.00	4.50	10.64	6.14
125	45	1/8	M1135059	612	13F20-34C	20	180	0.70	235	3.38	4.00	4.50	10.64	6.14
250	25	1/8	M1135040	612	13F10-34C	10	90	1.40	235	3.38	4.00	4.50	10.64	6.14
250	25	1/8	M1135060	612	13F10-34C	10	180	0.70	235	3.38	4.00	4.50	10.64	6.14
500	13	1/8	M1135041	612	13F05-34C	5	90	1.40	235	3.38	4.00	4.50	10.64	6.14
500	13	1/8	M1135061	612	13F05-34C	5	180	0.70	235	3.38	4.00	4.50	10.64	6.14
62	135	1/4	M1135042	635	13F40-34G	40	90	2.30	235	3.38	4.00	4.50	12.64	8.14
62	135	1/4	M1135062	635	13F40-34G	40	180	1.30	235	3.38	4.00	4.50	12.64	8.14
83	125	1/4	M1135043	635	13F30-34G	30	90	2.30	235	3.38	4.00	4.50	12.64	8.14
83	125	1/4	M1135063	635	13F30-34G	30	180	1.30	235	3.38	4.00	4.50	12.64	8.14
125	90	1/4	M1135044	635	13F20-34G	20	90	2.30	235	3.38	4.00	4.50	12.64	8.14
125	90	1/4	M1135064	635	13F20-34G	20	180	1.30	235	3.38	4.00	4.50	12.64	8.14
250	50	1/4	M1135045	635	13F10-34G	10	90	2.30	235	3.38	4.00	4.50	12.64	8.14
250	50	1/4	M1135065	635	13F10-34G	10	180	1.30	235	3.38	4.00	4.50	12.64	8.14
500	30	1/4	M1135046	635	13F05-34G	5	90	2.30	235	3.38	4.00	4.50	12.64	8.14
500	30	1/4	M1135066	635	13F05-34G	5	180	1.30	235	3.38	4.00	4.50	12.64	8.14

▲ Use "A" discount symbol.

**RIGHT-ANGLE DC • LOW VOLTAGE (12V)
TENV • 1.0 SERVICE FACTOR**

Output RPM	F.L. Torque (In.-Lbs.)	Input HP	Catalogue Number	List Price▲	Gearmotor Type & Frame	Ratio to 1	Arm Volts DC	Full Load Amps. DC	Over-hung Load (lbs.)	DIMENSIONS				
										P	PB	X Inches	XL	XH
42	80	1/8	M1135249	\$606	13F60-34	60	12	11.0	235	3.38	4.21	4.50	10.39	5.89
250	25	1/8	M1135250	606	13F10-34	10	12	11.0	235	3.38	4.21	4.50	10.39	5.89
62	135	1/4	M1135251	649	13F40-34	40	12	21.0	235	3.38	4.21	4.50	12.64	8.14
125	90	1/4	M1135252	649	13F20-34	20	12	21.0	235	3.38	4.21	4.50	12.64	8.14

▲ Use "A" discount symbol.

**BODINE/DAYTON
DIRECT INTERCHANGE**

10 SERIES - DC

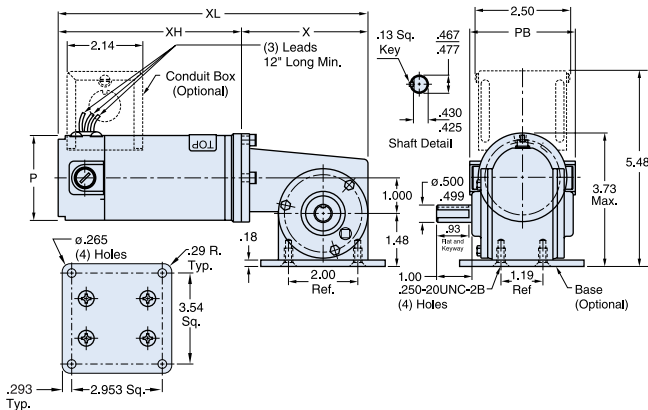

13 SERIES - DC

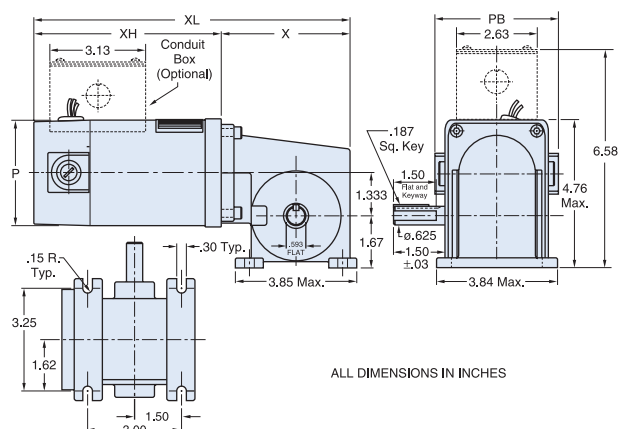

ALL DIMENSIONS IN INCHES

Gearmotors & Gears

SERIES 12 SUB-FHP

Electrical Specifications:

Both SCR (90 volt) and Low Voltage (12 volt) right angle gearmotors. The 90 volt motors are performance matched for continuous service over a 60:1 speed range. All have constant torque throughout the speed range when powered by a full-wave, unfiltered SCR-type 115 volt input adjustable speed control having a typical form factor of 1.3 to 1.4. The low voltage motors are also performance matched for continuous duty. Motors are designed for battery power or can be used with a low voltage controller with form factor up to 1.05.



Mechanical Specifications:

This worm-type right-angle gearing features hardened, steel worm with bronze worm wheel for long life and quiet operation. Single-piece die cast aluminum alloy housing is vacuum impregnated with Resinol RT for protection and sealing. This gearbox combines light weight with high tensile strength along with being precision machined for alignment of bearings and gearing. For optimum seal life, we use high-temperature Nitrile seals. Gearbox provided with solid output shaft, but can be converted to a hollow output shaft mounting by using snap-ring pliers and remove the snap ring and solid output shaft. Also the T-base feet are bolted to the gearbox, but can easily be removed and converted to face mounting.



RIGHT-ANGLE DC • SCR 90 VOLT RATED

TEFC • 1.0 SERVICE FACTOR

Input HP	F.L. Torque (In.-Lbs.)	Output RPM	Catalogue Number	List Price	Enclosure	Gearmotor Type & Frame	Ratio to 1	Full Arm Volts DC	Load Amps. DC
1/8*	125	28	M1135292	\$663	TENV	12B60-34D	61	90	1.6
1/8*	87	45	M1135291	663	TENV	12B39-34D	39	90	1.6
1/4	158	58	M1135290	697	TEFC	12B30-34G	30	90	2.8
1/4	100	90	M1135289	678	TEFC	12B19-34G	19	90	2.6
1/4	85	115	M1135288	697	TEFC	12B15-34G	15	90	2.6
1/4	61	167	M1135287	678	TEFC	12B11-34G	10.6	90	2.6
1/4	46	250	M1135286	700	TEFC	12B7-34G	7	90	2.6

* Supplied with TENV motor enclosure

RIGHT-ANGLE DC • LOW VOLTAGE (12V)

TENV • 1.0 SERVICE FACTOR

Input HP	F.L. Torque (In.-Lbs.)	Output RPM	Catalogue Number	List Price	Enclosure	Gearmotor Type & Frame	Ratio to 1	Arm Volts DC	Full Load Amps. DC
1/8	134	27	M1135285	\$690	TENV	12B60-34C	61	12	14
1/8	94	45	M1135284	692	TENV	12B39-34C	39	12	15
1/4	158	58	M1135297	741	TENV	12B30-34F	30	12	24
1/4	100	90	M1135296	721	TENV	12B19-34F	19	12	24
1/4	85	115	M1135295	741	TENV	12B15-34F	15	12	23
1/4	61	167	M1135294	721	TENV	12B11-34F	10.6	12	21
1/4	46	250	M1135293	741	TENV	12B7-34F	7	12	23

NOTES:

- Conduit box not supplied with the gearmotor. Mounting provisions are provided and can use conduit box kit catalogue number M1760007 found on page 171.
- For solid double output shaft, consult factory.

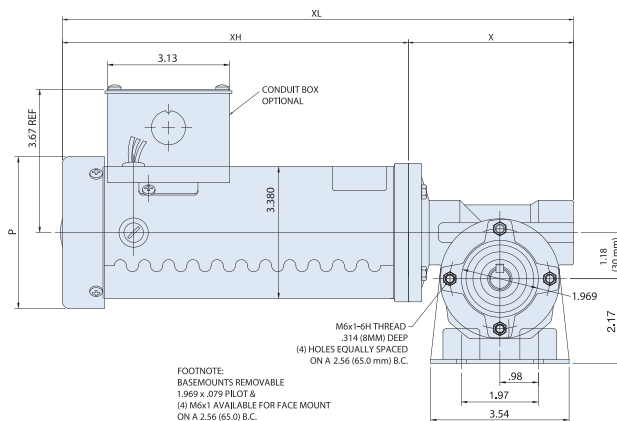

SCR 90 VOLT RATED DIMENSIONS (INCHES)

P	X	XL	XH	PB
3.38	4.32	11.07	6.75	4.00
3.38	4.32	11.07	6.75	4.00
3.88	4.32	13.16	8.84	3.76
3.88	4.32	13.16	8.84	3.76
3.88	4.32	13.16	8.84	3.76
3.88	4.32	13.16	8.84	3.76
3.88	4.32	13.16	8.84	3.76
3.88	4.32	13.16	8.84	3.76

LOW VOLTAGE (12V) DIMENSIONS (INCHES)

P	X	XL	XH	PB
3.38	4.32	10.57	6.25	4.21
3.38	4.32	10.57	6.25	4.21
3.38	4.32	11.82	7.5	4.21
3.38	4.32	11.82	7.5	4.21
3.38	4.32	11.82	7.5	4.21
3.38	4.32	11.82	7.5	4.21
3.38	4.32	11.82	7.5	4.21
3.38	4.32	11.82	7.5	4.21

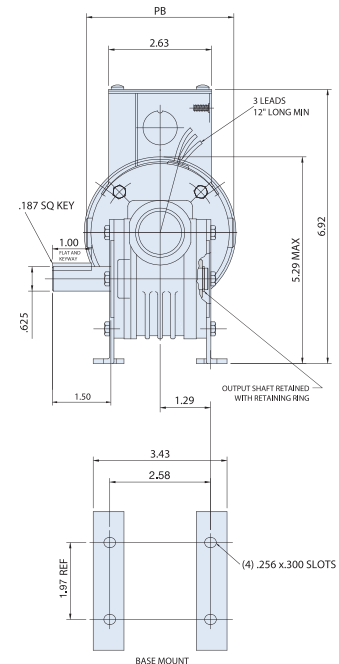

General Specifications:

DC permanent magnet gearmotors rated for continuous duty. Designed for use with fullwave non-filtered SCR controls or battery supplied low voltage for adjustable speed applications requiring constant torque throughout the speed range.



Mechanical Specifications:

Gearbox output shafts are coated with Miroton 3300 fortified Teflon for superior corrosion resistance.

Frame, endshields, armature and interior components protected by enamel and polyester compounds for resistance to moisture, acids, alkalies and oil.

Cast conduit box with threaded conduit holes and Nitrile gaskets keep water out. The conduit box cover is made from 304 stainless steel.

For any condensation that may accumulate inside the motor a one-way stainless steel vapor vent is provided. All hardware is stainless steel. Motor painted with white epoxy for superior corrosion resistance and protection. Machined fits between the endbells and motor frame are sealed with gaskets. Thru-bolt heads and nuts sealed with fiber washers. O-rings under each threaded brush cover.

Precision machined in-line steel gears, with a first stage steel helical gear followed by spur-type gears. Lubrication is permanent semi-fluid grease, reducing possibility of leakage. Output shafts have needle bearings for high load capacities.

Application Notes:

LEESON WASHGUARD™ motors are designed for extended life in applications requiring regular washdown or otherwise wet environments. Washguard™ motors retard the entrance of water. Extra protection for the motor's interior prevents rust and corrosion build-up and releases trapped moisture to insure a longer life than possible with a standard motor.

These gearmotors are designed for mounting at any angle, but shaft up with motor below should be avoided to prevent leakage of lubricant into the motor should the shaft seal fail.

Overhung load capacities shown are at center of the output shaft.

The motor's stall torque exceeds recommended full load torques for the gearboxes. A current limiting device should be used to prevent damage to the gear sets.

P300 SERIES • SCR RATED • 90V PARALLEL SHAFT • TENV • 1.0 SERVICE FACTOR

Output RPM	F.L. Torque (Lb.In.)	Input HP	Catalog Number	List Price▲	Gearmotor Type & Frame	Ratio to 1	Arm. Volts DC	Full Load Amps DC	Over-hung Load (Lbs.)	DIMENSIONS				
										P	PB	X Inches	XL	XH
5	353	1/20	M1125261	\$639	P303-31	336	90	.81	565	3.13	3.80	3.54	10.44	8.94
31	220	1/8	M1125262	653	P303-31	58	90	1.6	327	3.13	3.80	3.54	11.94	10.44
51	130	1/8	M1125263	620	P302-31	35	90	1.6	277	3.13	3.80	3.54	11.94	10.44
94	77	1/8	M1125264	620	P302-31	19	90	1.6	236	3.13	3.80	3.54	11.94	10.44
167	43	1/8	M1125265	620	P302-31	11	90	1.6	197	3.13	3.80	3.54	11.94	10.44

▲ Use "S" discount symbol.

P300 SERIES • LOW VOLTAGE (12V) PARALLEL SHAFT • TENV • 1.0 SERVICE FACTOR

Output RPM	F.L. Torque (Lb.In.)	Input HP	Catalog Number	List Price▲	Gearmotor Type & Frame	Ratio to 1	Arm. Volts DC	Full Load Amps DC	Over-hung Load (Lbs.)	DIMENSIONS				
										P	PB	X Inches	XL	XH
5	353	1/20	M1125266	\$642	P303-31	336	12	6.4	565	3.13	3.80	3.54	10.44	8.94
31	220	1/8	M1125267	662	P303-31	58	12	11.0	327	3.13	4.43	3.54	11.44	9.94

▲ Use "A" discount symbol.



White Duck

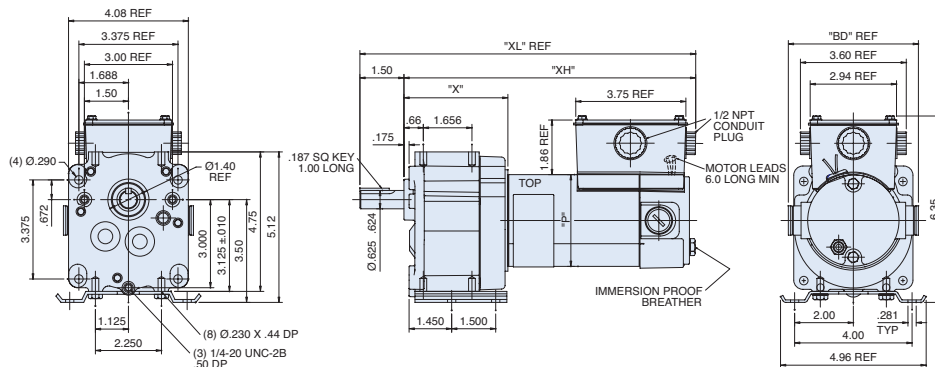

Catalog numbers in blue are NEW items.



IP55 WASHGUARD™ GEARMOTORS

PARALLEL SHAFT

General Specifications:

DC permanent magnet gearmotors rated for continuous duty. Designed for use with fullwave non-filtered SCR controls or battery supplied low voltage for adjustable speed applications requiring constant torque throughout the speed range.



Mechanical Specifications:

Gearbox output shafts are coated with Mirolon 3300 fortified Teflon for superior corrosion resistance.

Frame, endshields, armature and interior components protected by enamel and polyester compounds for resistance to moisture, acids, alkalis and oil.

Cast conduit box with threaded conduit holes and Nitrile gaskets keep water out. The conduit box cover is made from 304 stainless steel.

For any condensation that may accumulate inside the motor a one-way stainless steel vapor vent is provided. All hardware is stainless steel. Motor painted with white epoxy for superior corrosion resistance and protection. Machined fits between the endbells and motor frame are sealed with gaskets. Thru-bolt heads and nuts sealed with fiber washers. O-rings under each threaded brush cover.

Precision machined in-line steel gears, with a first stage steel helical gear followed by spur-type gears. Lubrication is permanent semi-fluid grease, reducing possibility of leakage. Output shafts have needle bearings for high load capacities.

Application Notes:

LEESON WASHGUARD motors are designed for extended life in applications requiring regular washdown or otherwise wet environments. WASHGUARD motors retard the entrance of water.

Extra protection for the motor's interior prevents rust and corrosion build-up and releases trapped moisture to insure a longer life than possible with a standard motor.

These gearmotors are designed for mounting at any angle, but shaft up with motor below should be avoided to prevent leakage of lubricant into the motor should the shaft seal fail.

Overhung load capacities shown are at center of the output shaft.

The motor's stall torque exceeds recommended full load torques for the gearboxes. A current limiting device should be used to prevent damage to the gear sets.

PE350 SERIES PARALLEL SHAFT

TENV • 1.0 SERVICE FACTOR • SCR RATED 90V

Output RPM	F.L. Torque (Lb.in.)	Input HP	Catalog Number	List Price▲	Gearmotor Type & Frame	Ratio to 1	Arm Volts DC	Full Load Amps DC	Over-hung Load (Lbs.)	DIMENSIONS				
										P	PB	X Inches	XL	XH
14	341	1/8	M1125268	\$633	P353-31	180	90	1.5	465	3.13	3.80	3.45	11.84	9.84
42	280	1/4	M1125269	734	P353-32	58	90	2.6	327	3.25	3.80	3.45	13.84	11.84
83	155	1/4	M1125270	701	P353-32	29	90	2.6	267	3.25	3.80	3.45	13.84	11.84
250	45	1/4	M1125271	701	P352-32	10	90	2.6	201	3.25	3.80	3.45	13.84	11.84
500	25	1/4	M1125272	701	P352-32	5	90	2.6	194	3.25	3.80	3.45	13.84	11.84

▲ Use "S" discount symbol.

PE350 SERIES PARALLEL SHAFT

TENV • 1.0 SERVICE FACTOR • LOW VOLTAGE 12V

Output RPM	F.L. Torque (Lb.in.)	Input HP	Catalog Number	List Price▲	Gearmotor Type & Frame	Ratio to 1	Arm Volts DC	Full Load Amps DC	Over-hung Load (Lbs.)	DIMENSIONS				
										P	PB	X Inches	XL	XH
14	341	1/8	M1125273	\$652	P353-31	180	12	12	465	3.13	4.43	3.45	11.58	9.58
42	325	1/4	M1125274	757	P353-32	58	12	20	327	3.25	4.43	3.45	13.84	11.84

▲ Use "S" discount symbol.



White Duck

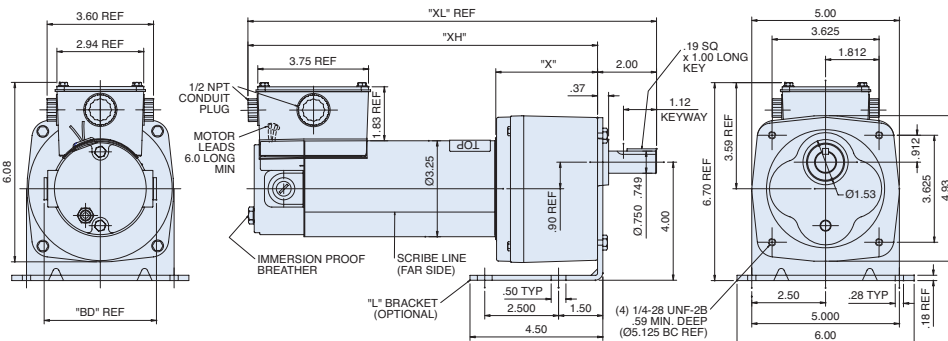

Catalog numbers in blue are NEW items.

General Specifications:

DC permanent magnet gearmotors rated for continuous duty. Designed for use with fullwave non-filtered SCR controls or battery supplied low voltage for adjustable speed applications requiring constant torque throughout the speed range.



Mechanical Specifications:

Gearbox output shafts are 303 stainless steel.

Frame, endshields, armature and interior components protected by enamel and polyester compounds for resistance to moisture, acids, alkalis and oil.

Cast conduit box with threaded conduit holes and Nitrile gaskets keep water out. The conduit box cover is made from 304 stainless steel.

For any condensation that may accumulate inside the motor a one-way stainless steel vapor vent is provided. All hardware is stainless steel. Motor painted with white epoxy for superior corrosion resistance and protection.

Machined fits between the endbells and motor frame are sealed with gaskets. Thru-bolt heads and nuts sealed with fiber washers. O-rings under each threaded brush cover.

This worm-type right-angle gearing features hardened, steel worm with bronze worm wheel for long life and quiet operation. Precision machined aluminum housings are used. Gearbox has all ball bearings. The housing is sealed and lubrication is permanent with an oil bath.

Application Notes:

LEESON WASHGUARD™ motors are designed for extended life in applications requiring regular washdown or otherwise wet environments. WASHGUARD™ motors retard the entrance of water.

Extra protection for the motor's interior prevents rust and corrosion build-up and releases trapped moisture to insure a longer life than possible with a standard motor.

For optimum seal life, these right-angle gearmotors have a lubrication breather positioned for horizontal mounting. For other mountings, the breather plug must be reoriented by using a 90 1/8 NPT taper pipe elbow. See page 161 or 170 for diagram.

Overhung load capacities shown are at center of the output shaft.

The motor's stall torque exceeds recommended full load torques for the gearboxes. A current limiting device should be used to prevent damage to the gear sets.

**RIGHT ANGLE • SCR RATED 90V
TENV • 1.0 SERVICE FACTOR**

Output RPM	F.L. Torque (Lb.In.)	Input HP	Catalog Number	List Price▲	Gearmotor Type & Frame	Ratio to 1	Arm Volts DC	Full Load Amps DC	Over-hung Load (Lbs.)	DIMENSIONS				
										P	PB	X Inches	XL	XH
42	80	1/8	M1125275	\$670	13F60-31	60	90	2.2	235	3.13	3.80	4.50	10.86	6.36
250	25	1/8	M1125276	670	13F10-31	10	90	2.2	235	3.13	3.80	4.50	10.86	6.36
62	135	1/4	M1125277	750	13F40-32	40	90	3.7	235	3.25	3.80	4.50	12.86	8.36
125	90	1/4	M1125278	750	13F20-32	20	90	3.7	235	3.25	3.80	4.50	12.86	8.36
250	50	1/4	M1125279	750	13F10-32	10	90	3.7	235	3.25	3.80	4.50	12.86	8.36

▲ Use "S" discount symbol.

**RIGHT ANGLE • LOW VOLTAGE 12V
TENV • 1.0 SERVICE FACTOR**

Output RPM	F.L. Torque (Lb.In.)	Input HP	Catalog Number	List Price▲	Gearmotor Type & Frame	Ratio to 1	Arm Volts DC	Full Load Amps DC	Over-hung Load (Lbs.)	DIMENSIONS				
										P	PB	X Inches	XL	XH
62	135	1/4	M1125280	\$780	13F40-32	40	12	20	235	3.25	4.43	4.50	12.36	7.86
125	90	1/4	M1125281	780	13F20-32	20	12	20	235	3.25	4.43	4.50	12.36	7.86

▲ Use "S" discount symbol.



White Duck

13 SERIES - DC

