



The heart of
your water system

Date:	June 1, 2006
Section: 4	Page: 1
Cancel & replace:	09-22-99

MS INJECTION CENTRIFUGAL PUMP

The MS injection centrifugal pump is exceptionally reliable and efficient. Specially designed for domestic purposes, it can also be used to pump water from wells, streams, ponds and many other water sources.

Molded in Polycarbonate, the high-precision impeller assures the MS model an optimum efficiency. To eliminate all vibrations, the impeller is screwed to the shaft of the motor.

Its stainless steel disc helps distinguish this pump from any other. In fact, this innovation facilitates the maintenance and minimises the corrosion.

The housing and the motor bracket are made of grey cast iron and are machined with precision to maximize performance. These parts are then treated with 2 layers of paint that gives a superior corrosion resistance.



CHARACTERISTICS

- ? Single-phase motor, **square flange**, 3450 RPM, 60 hz, 115/230 Volts, automatic thermal protection and stainless steel shaft.
- ? Pressure switch 30/50 lbs/in²
- ? Pressure gauge 0 - 100 P.S.I.
- ? Ejector not included.

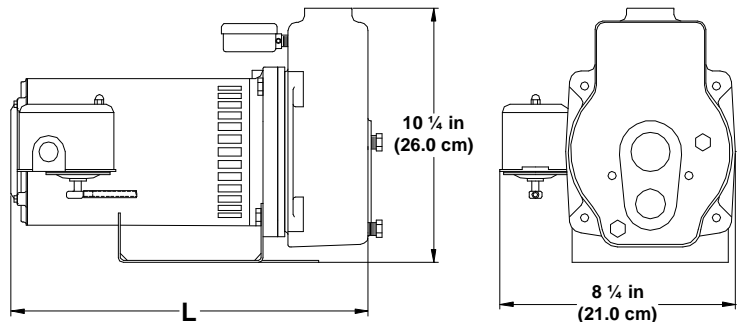

All pumps are tested in factory

**OPTION
EXTENDED 5 YEAR
WARRANTY PLAN OFFERED BY
THE MANUFACTURER**

Part number	Pump model	Motor H.P. (kW)	Suction inch (mm)	Discharge inch (mm)	L inch (cm)	Shipping weight lbs (kg)	Suggested list price
510-0050	MS-50	1/2 (.37)	1 1/4" (31.75)	1" (25.4)	14.75 (37.5)	40 (18)	489.00*
510-0075	MS-75	3/4 (.55)			15.50 (39.4)	42 (19)	547.00*
510-0100	MS-100	1.0 (.75)			14.00 (35.6)	45 (20)	610.00*



The heart of
your water system

Date:	June 1, 2006
Section: 4	Page: 2
Cancel & replace:	01-04-99

PERFORMANCE CHART

INJECTION CENTRIFUGAL PUMP FOR SHALLOW WELL APPLICATION

MS MODEL

MODEL	MOTOR H.P. (kW)	VENTURI & NOZZLE	DISCH. PRESSURE P.S.I. (kPa)	DEPTH OF WATER IN FEET (METERS)					Shut-off PSI (kPa)
				5 (1.52)	10 (3.05)	15 (4.57)	20 (6.1)	25 (7.62)	
CAPACITY - GALLONS U.S./HOUR (LITERS/HOUR)									
REGULAR PRESSURE									
MS-50	1/2 (.37)	326	20 (138)	1040 (3931)	920 (3478)	790 (2986)	560 (2117)	430 (1625)	60 (414)
			30 (207)	1010 (3818)	890 (3364)	780 (2948)	550 (2079)	420 (1588)	
			40 (276)	800 (3024)	750 (2835)	690 (2608)	510 (1928)	380 (1436)	
MS-75	3/4 (.55)	366	20 (138)	1350 (5103)	1185 (4479)	1070 (4045)	800 (3024)	570 (2155)	62 (427)
			30 (207)	1340 (5065)	1165 (4404)	1060 (4007)	795 (3005)	565 (2136)	
			40 (276)	1000 (3780)	940 (3553)	880 (3326)	740 (2797)	480 (1814)	
MS-100	1 (.75)	386	20 (138)	1430 (5405)	1225 (4631)	1150 (4347)	875 (3308)	650 (2457)	63 (434)
			30 (207)	1430 (5405)	1215 (4593)	1130 (4271)	870 (3289)	650 (2457)	
			40 (276)	1260 (4763)	990 (3742)	940 (3553)	780 (2948)	595 (2249)	
HIGH PRESSURE									
MS-50	1/2 (.37)	287	30 (207)	780 (2948)	710 (2684)	612 (2313)	510 (1928)	410 (1550)	75 (518)
			40 (276)	590 (2230)	530 (2003)	460 (1739)	380 (1436)	315 (1191)	
			50 (345)	370 (1399)	340 (1285)	300 (1134)	250 (945)	205 (775)	
			60 (414)	185 (699)	170 (642)	150 (567)	125 (472)	100 (378)	
MS-75	3/4 (.55)	327	30 (207)	1080 (4082)	975 (3686)	845 (3194)	700 (2646)	565 (2136)	72 (497)
			40 (276)	990 (3742)	895 (3383)	775 (2930)	640 (2419)	520 (1965)	
			50 (345)	670 (2532)	605 (2287)	525 (1985)	440 (1663)	360 (1361)	
			60 (414)	380 (1436)	345 (1304)	300 (1134)	250 (945)	210 (794)	
MS-100	1 (.75)	347	30 (207)	1160 (4385)	1050 (3969)	910 (3440)	750 (2835)	610 (2306)	74 (511)
			40 (276)	1150 (4347)	1040 (3931)	900 (3402)	740 (2797)	600 (2268)	
			50 (345)	840 (3175)	760 (2873)	660 (2495)	550 (2079)	450 (1701)	
			60 (414)	490 (1852)	450 (1701)	390 (1474)	325 (1229)	270 (1021)	

REGULAR PRESSION

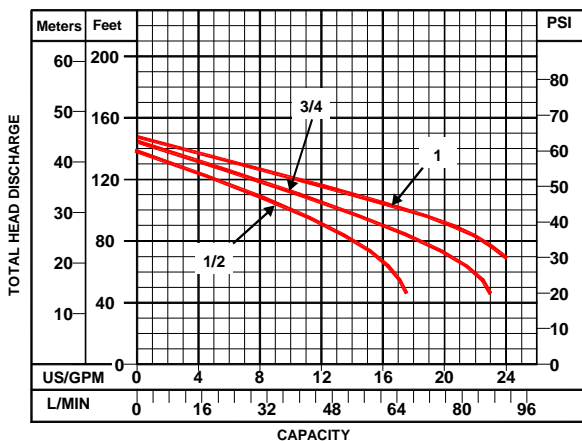

HIGH PRESSURE

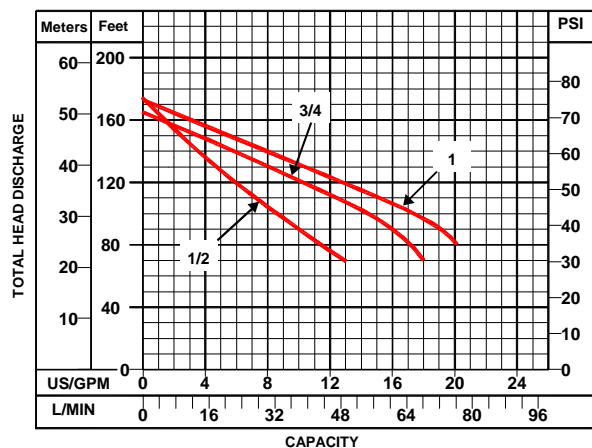



The heart of
your water system

Date:	June 1, 2006
Section: 4	Page: 3
Cancel & replace:	01-04-99

PERFORMANCE CHART INJECTION CENTRIFUGAL PUMP FOR DEEP WELL APPLICATION MS MODEL

MODEL	MOTOR H.P. (kW)	VENTURI & NOZZLE	DISCH. PRESSURE P.S.I. (kPa)	DEPTH OF WATER IN FEET											
				20	30	40	50	60	70	80	90	100	110	120	
CAPACITY - U.S. GALLONS / HOUR															
MS-50	1/2	245	20	670	650	580	500	400	280						
			30	610	530	450	380	300	200						
			40	430	360	290	210	140	70						
			50	240	180	130	80	20							
		235	20			500	430	360	290	220					
			30			390	330	280	220	170					
			40			240	200	160	120	80					
			50			140	105	70	30						
		225	20				310	300	280	210	160	100			
			30				310	280	230	180	120	80			
			40				220	180	140	100	50	20			
			50				110	85	60	30					
MS-75	3/4	234	20	910	810	690	570	460	340						
			30	770	640	580	490	400	300						
			40	600	510	420	340	230	150						
			50	380	310	230	170	70							
		226	20				470	450	430	360	260	215	150		
			30				470	440	410	350	260	215	140		
			40				420	360	300	250	170	130	60		
			50				290	250	200	170	90	50			
		225	20						310	280	240	200	160	110	80
			30						260	250	210	180	160	110	80
			40						240	200	170	140	100	60	30
			50						140	110	80	70	30	10	
MS-100	1	234	20	910	910	770	630	480	360	230					
			30	910	780	670	540	430	320	210					
			40	700	600	500	380	300	200	110					
			50	480	390	310	210	130	50						
		226	20				470	470	450	380	280	230	160	100	
			30				470	470	420	370	270	220	150	100	
			40				430	380	320	270	200	150	90	50	
			50				310	260	210	180	110	60	10		
		225	20						310	290	250	210	170	120	90
			30						310	280	240	190	170	120	90
			40						265	230	190	150	110	70	40
			50						160	130	100	75	40	15	

To convert **feet** to **meters**: multiply by 0.3048
 To convert **U.S. gallons** to **liters**: multiply by 3.785



The heart of
your water system

Date:	June 1, 2006
Section: 4	Page: 4
Cancel & replace:	February 1, 2002

INJECTION CENTRIFUGAL PUMP EJECTOR KITS MS MODEL

SHALLOW WELL EJECTOR KITS

(included: ejector body, venturi tube, nozzle, ejector gasket, bolts and washers)



REGULAR PRESSURE						
Part number	Model	H.P.	Diameter		Shipping weight Lbs (Kg)	Suggested list price
			Venturi	Nozzle		
513-0160	OJ-7-50S	1/2	32/64	16/64	5 (2.25)	60.00
513-0170	OJ-7-75S	3/4	36/64	16/64	5 (2.25)	60.00
513-0180	OJ-7-100S	1	38/64	16/64	5 (2.25)	60.00

HIGH PRESSURE						
Part number	Model	H.P.	Diameter		Shipping weight Lbs (Kg)	Suggested list price
			Venturi	Nozzle		
513-0165	OJ-7-50H	1/2	28/64	17/64	5 (2.25)	60.00
513-0175	OJ-7-75H	3/4	32/64	17/64	5 (2.25)	60.00
513-0185	OJ-7-100H	1	34/64	17/64	5 (2.25)	60.00

DEEP WELL EJECTOR KITS

(included: ejector body, venturi tube and nozzle)



Part number	Model	Diameter		Shipping weight Lbs (Kg)	Suggested list price
		Venturi	Nozzle		
513-0190	AJ37 FP 225	22/64	15/64	5 (2.25)	66.00
513-0200	AJ37 FP 235	23/64	15/64	5 (2.25)	66.00
513-0210	AJ37 FP 226	22/64	16/64	5 (2.25)	66.00
513-0230	AJ37 FP 245	24/64	15/64	5 (2.25)	66.00
513-0250	AJ37 FP 234	23/64	14/64	5 (2.25)	66.00

PUMP + TANK ASSEMBLED KIT

Kits include: pump, tank & galvanized fittings
(everything is assembled & shipped in one box)



Part number	Pump	Tank	Suggested list price
512-1000	MS-50	H060 (14 gal)	869.00*

The H060 tank has a 1 year warranty

PVC COUPLING KITS

Included: (necessary couplings to link
the injection centrifugal pump to the AMTROL tank)

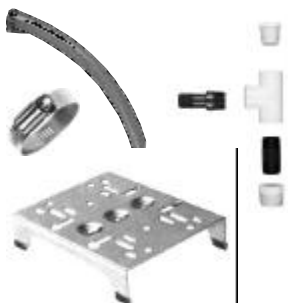

Part number	Tank	Suggested list price
120-4300	WX-200 PS	31.80*
120-5200	WX-202 PA	54.00*