



The heart of
your water system

Date:	June 1, 2006
Section: 1	Page: 1
Cancel & replace:	February 14, 2005

PISTON PUMP

For shallow wells and well points: it's used mostly on farms, residences, cottages, solar applications and sprinkling systems.

FEATURES

- ? On site maintenance possible due to easy access to internal parts
- ? Built tough for longer life span
- ? Constant pumping even with presence of air in water
- ? Double-action piston, single cylinder
- ? Continuous efficiency at various pressures.
- ? Increased resistance to particles in water.
- ? Priming up to 25 feet (7.62 m)
- ? Safety valve 100 PSI
- ? Available in 3 models (S-275, S-450, S-600) and 2 versions:

2 versions:

Complete Pump: (pump, motor, pressure switch set at 30/50 lbs/in²)

Pump only

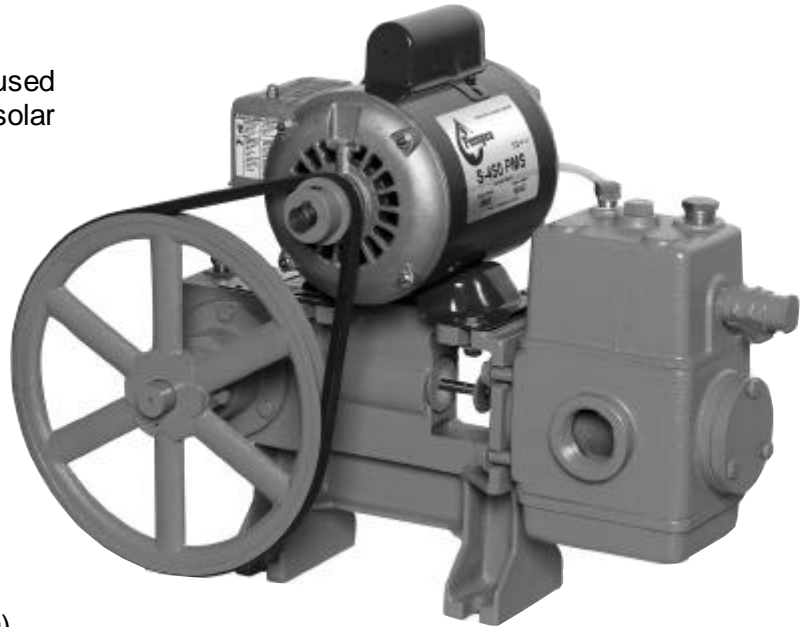

Dimension with 1/3 HP motor

CHARACTERISTICS

- ? 1/3 or 1/2 H.P. motor, 115/230 Volts, capacitor starter, automatic thermal protection
- ? Main components: grey cast iron, bronze and stainless steel.

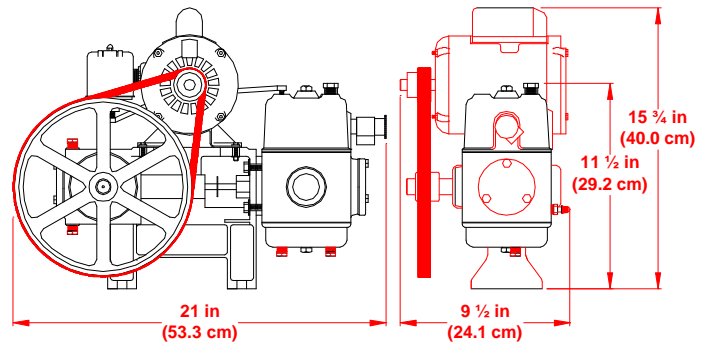

Each pump is tested in our factory.

Part number	Pump model	H.P.	Capacity	Suction inch (mm)	Discharge inch (mm)	Shipping weight lbs (kg)	Suggested list price
521-0005	S-275 with motor	1/3	275 gallons/h (1040 liters/h)	1 1/4" (31.8)	1" (25.4)	70 (32)	826.00
521-0010	S-275 pump only					54 (25)	599.00
521-0015	S-450 with motor	1/3	450 gallons/h (1703 liters/h)			70 (32)	880.00
521-0020	S-450 pump only					54 (25)	640.00
521-0025	S-600 with motor	1/2	600 gallons/h (2271 liters/h)			78 (35)	952.00
521-0030	S-600 pump only					54 (25)	653.00