



The heart of
your water system

Date:	June 1, 2006
Section: 6	Page: 1
Cancel & replace:	01-04-99

PLSH

SELF-PRIMING CENTRIFUGAL PUMP

"BUILT TOP QUALITY"

Ideal for lawn sprinkling systems, irrigation and other areas where high capacity self-priming pumps are required.

FEATURES

- ? On site maintenance possible due to easy access to internal parts.
- ? Maximum water volume in pump housing assures easy and fast priming.
- ? Unique design of housing and polycarbonate+fiber impeller helps provide high heads.
- ? Hard to unprime even with air in water.
- ? Long life assured by non-corrosive paint and strong construction.

CHARACTERISTICS

- ? Single phase motor, **square flange**, 60 Hz, 115/230 Volts, capacitor starting, automatic thermal protection
- ? Priming up to 25 feet (**7.62 m**)

All pumps are tested in factory

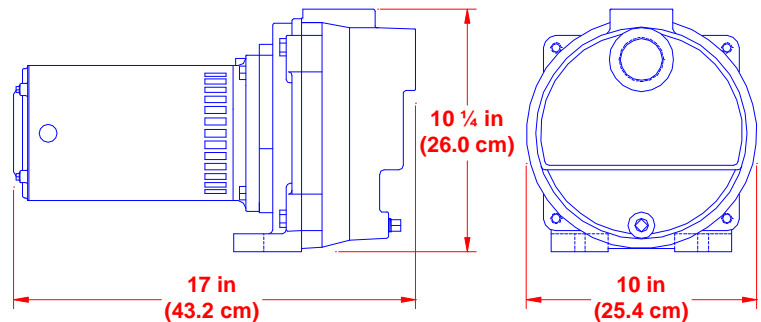

Part number	Pump model	Motor HP (kW)	Suction inch (mm)	Discharge inch (mm)	Shipping weight lbs (kg)	Suggested list price
335-0075	PLSH-75	3/4 (.55)	1 1/2" (38.10)	1 1/2" (38.10)	63 (29)	566.00*
335-0100	PLSH-100	1.0 (.75)	1 1/2" (38.10)	1 1/2" (38.10)	65 (30)	630.00*
335-0150	PLSH-150	1.5 (1.1)	1 1/2" (38.10)	1 1/2" (38.10)	70 (32)	799.00*
335-0200	PLSH-200	2.0 (1.5)	1 1/2" (38.10)	1 1/2" (38.10)	75 (34)	932.00*



The heart of
your water system

Date:	June 1, 2006
Section: 6	Page: 2
Cancel & replace:	01-04-99

PLSH MODEL PERFORMANCE CHART

CAPACITY IN GALLONS PER MINUTE

Model	Motor H.P. (kW)	Discharge pressure P.S.I. (kPa)	Pumping depth in feet (Meters)				
			5 (1.52)	10 (3.05)	15 (4.57)	20 (6.10)	25 (7.62)
PLSH-75	3/4 (.55)	10 (69)	52 (197)	49 (185)	45 (170)	41 (155)	35 (132)
		20 (138)	46 (174)	44 (166)	40 (151)	36 (136)	30 (113)
		30 (207)	39 (147)	35 (132)	30 (113)	25 (95)	19 (72)
PLSH-100	1.0 (.75)	10 (69)	56 (212)	52 (197)	49 (185)	45 (170)	37 (140)
		20 (138)	52 (197)	48 (181)	45 (170)	40 (150)	32 (121)
		30 (207)	45 (170)	40 (151)	37 (140)	30 (113)	22 (83)
		40 (276)	20 (76)	14 (53)			
PLSH-150	1.5 (1.1)	10 (69)	63 (238)	59 (223)	55 (208)	50 (189)	39 (148)
		20 (138)	58 (219)	55 (208)	51 (193)	46 (174)	35 (133)
		30 (207)	53 (200)	50 (189)	45 (170)	40 (150)	26 (98)
		40 (276)	32 (121)	26 (98)	13 (49)		
PLSH-200	2.0 (1.5)	10 (69)	74 (281)	70 (266)	66 (248)	59 (224)	47 (179)
		20 (138)	71 (268)	68 (258)	62 (236)	56 (212)	44 (166)
		30 (207)	64 (241)	61 (229)	56 (212)	51 (192)	39 (147)
		40 (276)	44 (168)	38 (143)	26 (99)		

Model	PLSH-75	PLSH-100	PLSH-150	PLSH-200
Shut off P.S.I. (kPa)	43 (296)	44 (303)	46 (317)	48 (330)

