

## **KS Vertical Split Coupled Inline Pumps**

Taco Vertical Split Coupled inline pumps set a new standard in service and maintenance.



**HYDRONIC COMPONENTS & SYSTEMS**

**Do it once.  
Do it right.** 

## Features & Benefits

### Quiet, dependable power. Proven performance.

Taco's line of vertical split coupled in-line pumps are designed for optimum performance and ease of installation and maintenance. They're ideal for HVAC and industrial applications, including pressure boosting, cooling towers, and domestic water service flows to 2500 GPM. For quick and easy repair, the split coupler design permits changing of the seal without disturbing the motor or piping. The axial load is hydraulically balanced to increase bearing life and deliver better pump efficiencies and lower NPSH requirements. The recirculating line flushes seal faces and extends seal life, resulting in less pump downtime due to seal leaks. Optimum pump efficiency is achieved by close running impeller to casing clearances.

Other important features include:

**Motor Drive** is isolated from the system with the split coupler design.

**Precision** aluminum coupling.

**High efficiency** impellers standard on all sizes.

**Standard** drilled and tapped mounting holes at base of casing.

**A seal flush line** is standard on all models.

**Throttle Bushing** keeps contaminants away from the seal.

**Replaceable casing wear ring, pump support bracket, and external seal** are all value added options.

- ① Stainless steel pump shaft
- ② Standard seal design allows for flexibility of seal options.
- ③ Pressure tapping on suction and discharge for easy verification of pump performance.

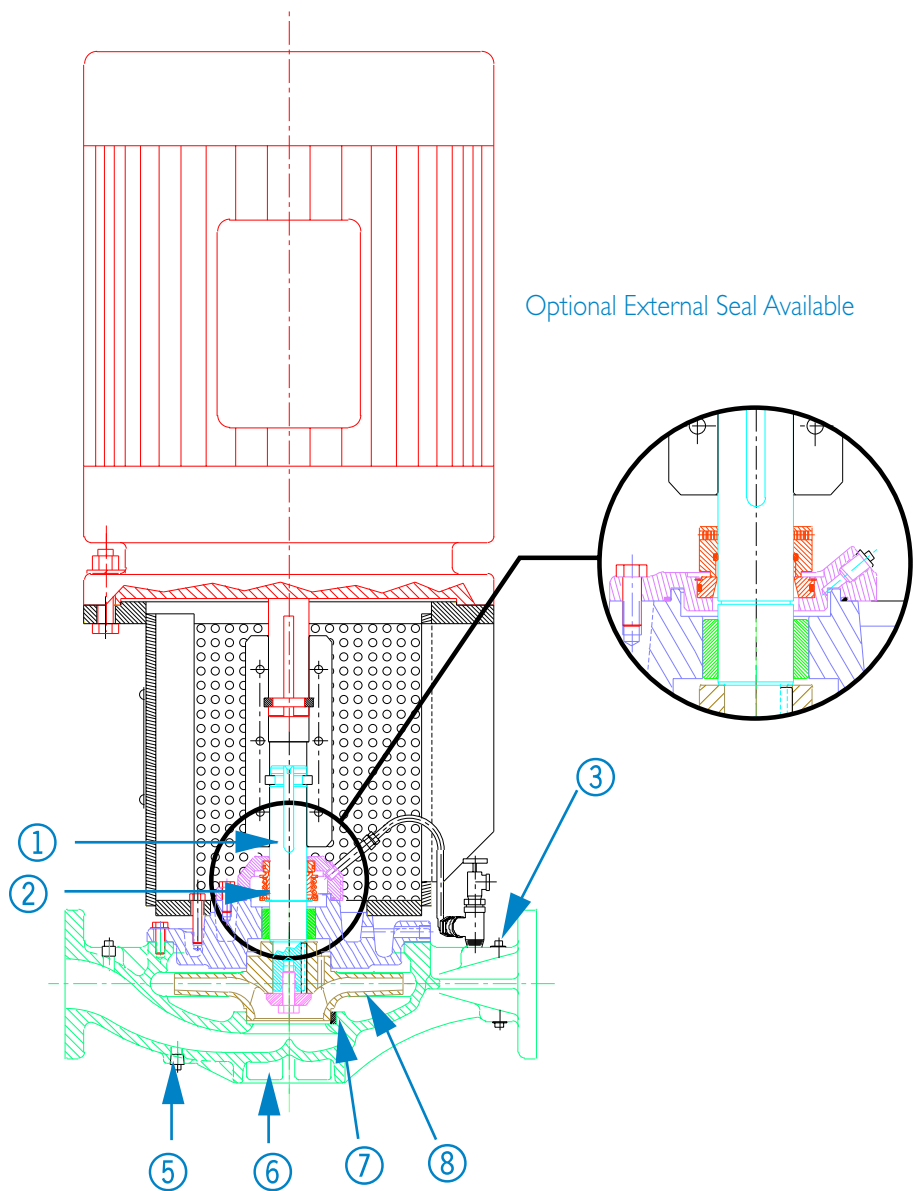

- ④ 250# flanges available
- ⑤ Casing drain
- ⑥ Machined mounting surface with tapped holes
- ⑦ Low cost replaceable optional wear ring available
- ⑧ High efficiency impellers standard on all models

# Commercial Hydronic Application Information

## Part I – Fundamentals

A centrifugal pump operated at constant speed delivers any capacity from zero to maximum depending on the head, design and suction conditions. Pump performance is most commonly shown by means of plotted curves which are graphical representations of a pump's performance characteristics. Pump curves present the average results obtained from testing several pumps of the same design under standardized test conditions. For a single family residential application, considerations other than flow and head are of relatively little economic or functional importance, since the total load is small and the equipment used is relatively standardized. For many smaller circulators, only the flow and pressure produced are represented on the performance curve (Fig. I-1).

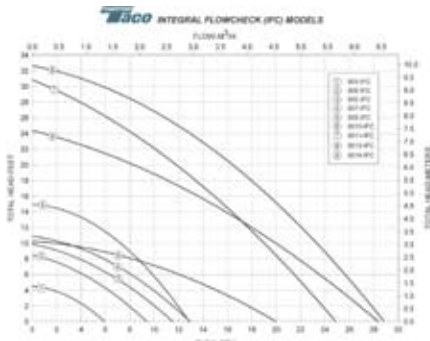

Fig. I-1

For larger and more complex buildings and systems, economic and functional considerations are more critical, and performance curves must relate the hydraulic efficiency, the power required, the shaft speed, and the net positive suction head required in addition to the flow and pressure produced (Fig. I-2).

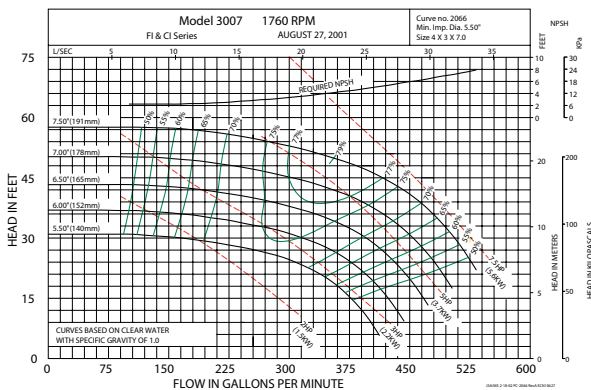

Fig. I-2

Pump performance curves show this interrelation of pump head, flow and efficiency for a specific impeller diameter and casing size. Since impellers of more than one diameter can usually be fitted in a given pump casing, pump curves show the performance of a given pump with impellers of various diameters. Often, a complete line of pumps of one design is available and a plot called a composite or quick selection curve can be used, to give a complete picture of the available head and flow for a given pump line (Fig. I-3).

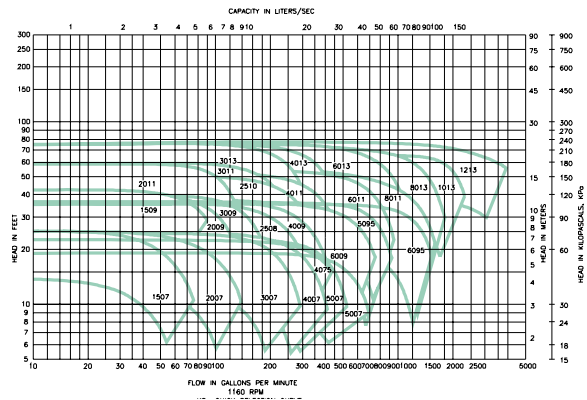

Fig. I-3

Such charts normally give flow, head and pump size only, and the specific performance curve must then be referred to for impeller diameter, efficiency, and other details. For most applications in our industry, pump curves are based on clear water with a specific gravity of 1.0.

## Part II – The System Curve

Understanding a system curve, sometimes called a system head curve, is important because conditions in larger, more complex piping systems vary as a result of either controllable or uncontrollable changes. A pump can operate at any point of rating on its performance curve, depending on the actual total head of a particular system. Partially closing a valve in the pump discharge or changing the size or length of pipes are changes in system conditions that will alter the shape of a system curve and, in turn, affect pump flow. Each pump model has a definite capacity curve for a given impeller diameter and speed. Developing a system curve provides the means to determine at what point on that curve a pump will operate when used in a particular piping system.

# Commercial Hydronic Application Information

Pipes, valves and fittings create resistance to flow or friction head. Developing the data to plot a system curve for a closed Hydronic system under pressure requires calculation of the total of these friction head losses. Friction tables are readily available that provide friction loss data for pipe, valves and fittings. These tables usually express the losses in terms of the equivalent length of straight pipe of the same size as the valve or fitting. Once the total system friction is determined, a plot can be made because this friction varies roughly as the square of the liquid flow in the system. This plot represents the SYSTEM CURVE. By laying the system curve over the pump performance curve, the pump flow can be determined (Fig. 2-1).

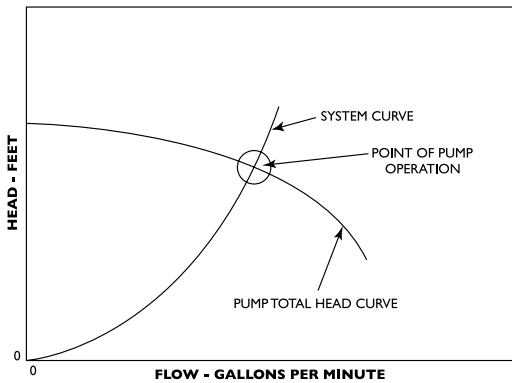

Fig. 2-1

Care must be taken that both pump head and friction are expressed in feet and that both are plotted on the same graph. The system curve will intersect the pump performance curve at the flow rate of the pump because this is the point at which the pump head is equal to the required system head for the same flow.

Fig. 2-2 illustrates the use of a discharge valve to change the system head to vary pump flow. Partially closing the valve shifts the operating point to a higher head or lower

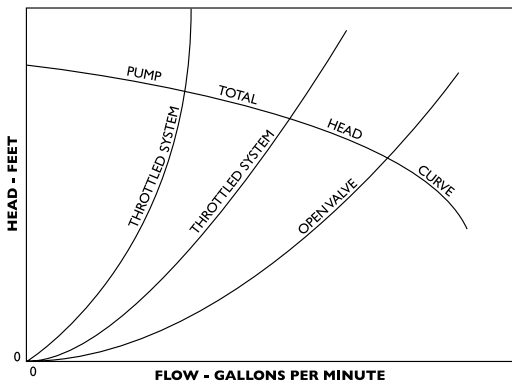

Fig. 2-2

flow capacity. Opening the valve has the opposite effect. Working the system curve against the pump performance curve for different total resistance possibilities provides the system designer important information with which to make pump and motor selection decisions for each system. A system curve is also an effective tool in analyzing system performance problems and choosing appropriate corrective action.

In an open Hydronic system, it may be necessary to add head to raise the liquid from a lower level to a higher level. Called static or elevation head, this amount is added to the friction head to determine the total system head curve. Fig. 2-3 illustrates a system curve developed by adding static head to the friction head resistance.

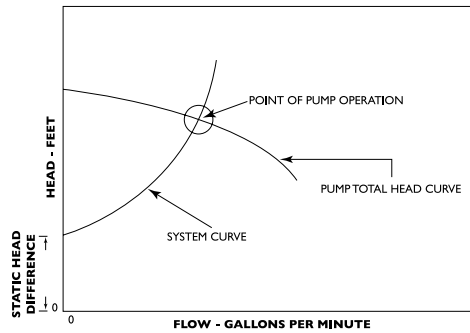

Fig. 2-3

## Part III – Stable Curves, Unstable Curves And Parallel Pumping

One of the ways in which the multitude of possible performance curve shapes of centrifugal pumps can be subdivided is as stable and unstable. The head of a stable curve is highest at zero flow (shutoff) and decreases as the flow increases. This is illustrated by the curve of Pump 2 in Fig. 3 – 1.

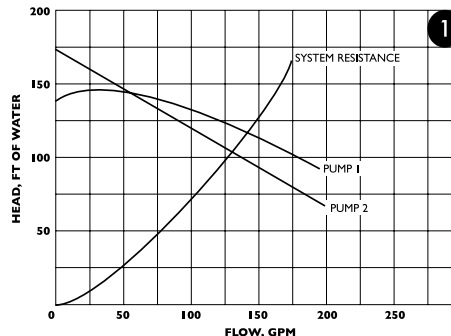

Fig. 3-1

So-called unstable curves are those with maximum head not at zero, but at 5 to 25 percent of maximum flow, as shown by the curve for Pump 1 in Fig. 3 – 1.

The term unstable, though commonly used, is rather unfortunate terminology in that it suggests unstable pump performance. Neither term refers to operating characteristic, however. Each is strictly a designation for a particular shape of curve. Both stable and unstable curves have advantages and disadvantages in design and application. It is left to the discretion of the designer to determine the shape of his curve.

In a vast majority of installations, whether the pump curve is stable or unstable is relatively unimportant, as the following examples of typical applications show.

## Single Pump In Closed System

In a closed system, such as a Hydronic heating or cooling system, the function of the pump is to circulate the same quantity of fluid over and over again. Primary interest is in providing flow rate. No static head or lifting of fluid from one level to another takes place.

All system resistance curves originate at zero flow any head. Any pump, no matter how large or small, will produce some flow in a closed system.

For a given system resistance curve, the flow produced by any pump is determined by the intersection of the pump curve with the system resistance curve since only at this point is operating equilibrium possible. For each combination of system and pump, one and only one such intersection exists. Consequently, whether a pump curve is stable or unstable is of no consequence. This is illustrated in Fig. 3 – 1.

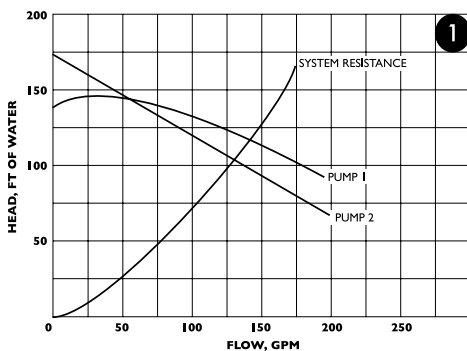

Fig. 3-1

## Single Pump In Open System With Static Head

In an open system with static head, the resistance curve originates at zero flow and at the static head to be overcome. The flow is again given by the intersection of system resistance and pump curves as illustrated for a stable curve in Fig. 3–2.

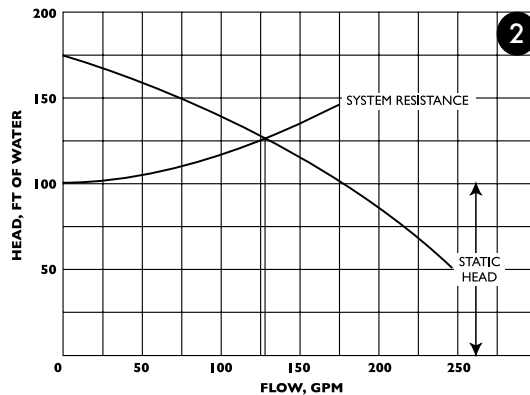

Fig. 3-2

It has been said that in an open system with static head a condition could exist where an unstable curve could cause the flow to “hunt” back and forth between two points since the system resistance curve intersects the pump curve twice, as shown in Fig. 3–3. The fallacy of this reasoning lies, in the fact that the pump used for the system in Fig. 3–3 already represents an improper selection in that it can never deliver any fluid at all. The shutoff head is lower than the static head. The explanation for this can be found in the manner in which a centrifugal pump develops its full pressure when the motor is started. The very important fact to remember here is that the shutoff head of the pump must theoretically always be at least equal to the static head.

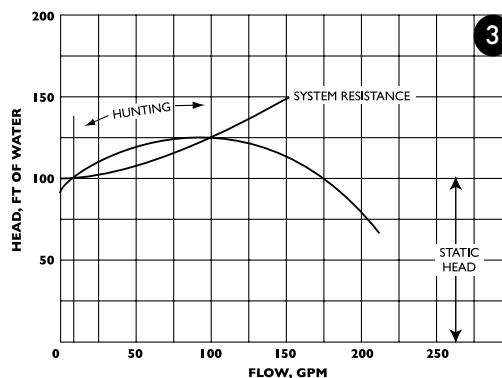

Fig. 3-3

# Commercial Hydronic Application Information

From a practical point of view, the shutoff head should be 5 to 10 percent higher than the static head because the slightest reduction in pump head (such as that caused by possible impeller erosion or lower than anticipated motor speed or voltage) would again cause shutoff head to be lower than static head. If the pump is properly selected, there will be only one resistance curve intersection with the pump curve and definite, unchanging flow will be established, as shown in Fig. 3-4.

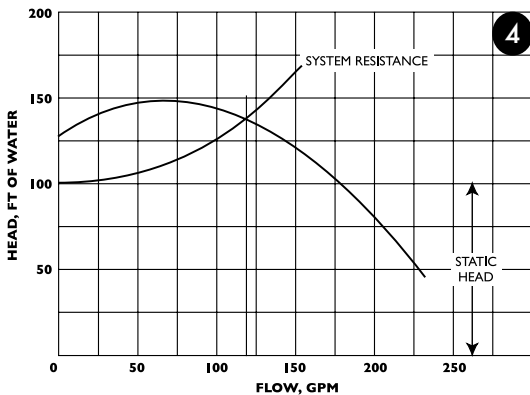

Fig. 3-4

## Pumps Operating In Parallel

In more complex piping systems, two or more pumps may be arranged for parallel or series operation to meet a wide range of demand in the most economical manner. When demand drops, one or more pumps can be shut down, allowing the remaining pumps to operate at peak efficiency. Pumps operating in Parallel give multiple flow capacity against a common head. When pumps operate in series, performance is determined by adding heads at the same flow capacity. Pumps to be arranged in series or parallel require the use of a system curve in conjunction with the composite pump performance curves to evaluate their performance under various conditions.

It is sometimes heard that for multiple pumping the individual pumps used must be stable performance curves. Correctly designed installations will give trouble-free service with either type of curve, however.

The important thing to remember is that additional pumps can be started up only when their shutoff heads are higher than the head developed by the pumps already running.

5.

If a system with fixed resistance (no throttling devices such as modulating valves) is designed so that its head, with all pumps operating (maximum flow) is less than the shutoff head of any individual pump, the different pumps may be operated singly or in any combination, and any starting sequence will work. Fig. 3-5 shows an example consisting of two dissimilar unstable pumps operating on an open system with static head.

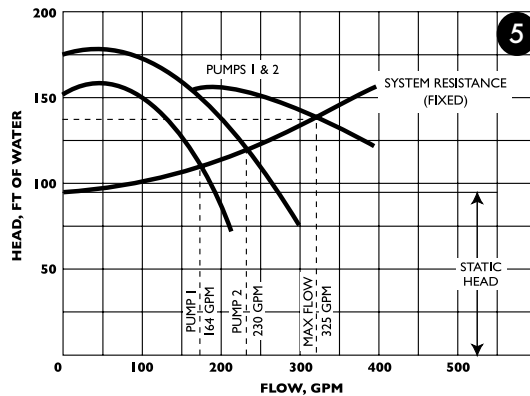

Fig. 3-5

It is also important to realize that stable curves do not guarantee successful parallel pumping by the mere fact that they are stable. Fig. 3-6 illustrates such a case. Two dissimilar pumps with stable curves are installed in a closed system with variable resistance (throttling may be affected by manually operated valves, for example).

With both pumps running, no benefit would be obtained from Pump 1 with the system resistance set to go through A, or any point between 0 and 100 GPM, for that matter. In fact, within that range, fluid from Pump 2 would flow backward through Pump 1 in spite of its running, because pressure available from Pump 2 would flow backward through Pump 1 in spite of its running, because pressure available from Pump 2 is greater than that developed by Pump 1.

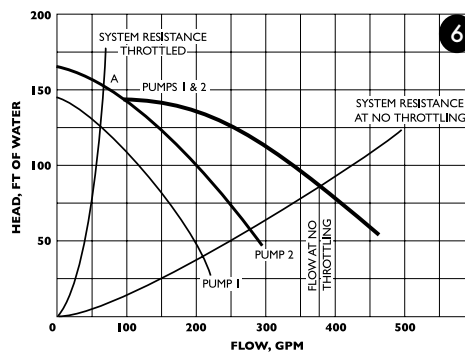

Fig. 3-6



In other words, Pump 2 overpowers Pump 1. For this reason, with Pump 2 running alone, Pump 1 should not be started unless Pump 2 operates to the right of the point where the curve of Pump 2 and the curve of Pumps 1 and 2 diverge (100 GPM) in Fig.3–6.

Parallel pumping is often an excellent way to obtain optimum operating conditions and to save energy. To be successful, however, systems and operating conditions must be understood. This applies to both stable and unstable pump curves.

## Part IV – NPSH And Pump Cavitation

The net positive suction head (NPSH) is an expression of the minimum suction conditions required to prevent cavitation in a pump. NPSH can be thought of as the head corresponding to the difference between the actual absolute pressure at the inlet to the pump impeller and the fluid vapor pressure. An incorrect determination of NPSH can lead to reduced pump capacity and efficiency, severe operating problems and cavitation damage.

It is helpful to define separately two basic NPSH considerations; required NPSH (NPSHR) and available (NPSHA).

The required or minimum NPSH is dependent on the design of a particular pump and is determined by the manufacturer's testing of each pump model. The pump manufacturer can plot this required NPSH for a given pump model on performance curve and this value, expressed as feet of the liquid handled, is the pressure required to force a given flow through the suction piping into the impeller eye of the pump. Required NPSH can also be defined as the amount of pressure in excess of the vapor pressure required by a particular pump model to prevent the formation of vapor pockets or cavitation. Required NPSH, then, varies from one pump manufacturer to the next and from one manufacturer's model to another. The required NPSH for a particular pump model varies with capacity and rapidly increases in high capacities.

The available NPSH, on the other hand, is dependent on the piping system design as well as the actual location of the pump in that system. The NPSH available as a function of system piping design must always be greater than the NPSH required by the pump in that system. The NPSH available as a function of system piping design must always be greater

than the NPSH required by the pump in that system or noise and cavitation will result. The available NPSH can be altered to satisfy the NPSH required by the pump, if changes in the piping liquid supply level, etc., can be made. Increasing the available NPSH provides a safety margin against the potential for cavitation. The available NPSH is calculated by using the formula:

$$\text{NPSHA} = h_a \pm h_s - h_{vpa} - h_f$$

where:

$h_a$  = atmospheric pressure in feet absolute

$h_s$  "+" = suction head or positive pressure in a closed system, expressed in feet gauge

$h_s$  "-" = suction lift or negative pressure in a closed system, expressed in feet gauge

$h_{vpa}$  = vapor pressure of the fluid in feet absolute

$h_f$  = pipe friction in feet between pump suction and suction reference point.

Cavitation can be defined as the formation and subsequent collapse of vapor pockets in a liquid. Cavitation in a centrifugal pump begins to occur when the suction head is insufficient to maintain pressures above the vapor pressure. As the inlet pressure approaches the flash point, vapor pockets form bubbles on the underside of the impeller vane which collapse as they move into the high-pressure area along the outer edge of the impeller. Severe cavitation can cause pitting of the impeller surface and noise levels audible outside the pump.

The Taco pump performance curve below (Fig. 4–1) includes a plot of the required NPSH for a Taco Model 1506. If a pump capacity of 105 GPM is used as an example capacity requirement, reading vertically from that GPM rate shows a required NPSH of 4 feet. An available system NPSH greater than 4 feet would, therefore, be necessary to ensure satisfactory pump performance and operation.

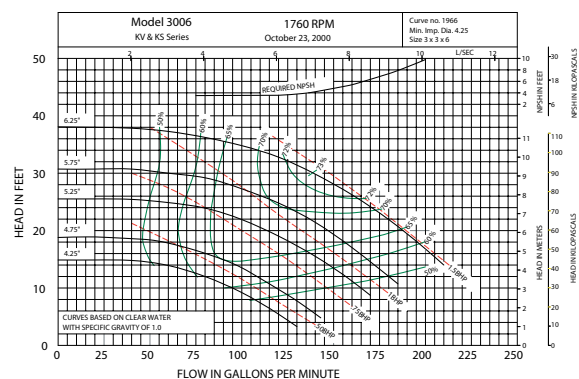
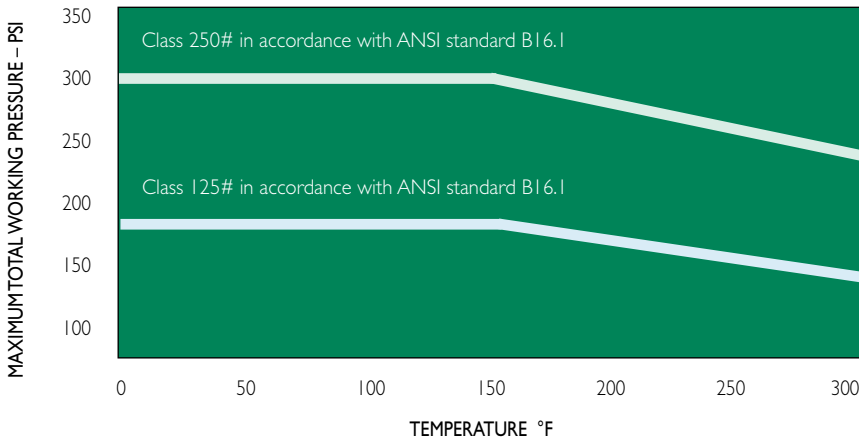

Fig. 4-1

## Commercial Hydronic Application Information

### Pressure-Temperature Ratings



OPERATING SPECIFICATIONS		
	Standard	Optional
Flange	Class 125*	Class 250*
Pressure	175 PSIG* 1210 KPA	300 PSIG* 2070 KPA
Temperature	250°F 120°C**	250°F 102°C**

ADDITIONAL OPTIONS	
Filters	Cuno 5 Micron
Separators	Kynar Cyclone Separator

\* Per Pressure Temperature Ratings chart above.

### Typical Specification

Furnish and install centrifugal in-line single stage pump(s) with capacities and characteristics as shown on the plans. The design must permit easy replacement of the mechanical shaft seal without removal of the motor. Pumps shall be Taco Model KS or approved equal.

Pump volute or casings shall be constructed of class 30 cast iron. The pump casing shall have equal suction and discharge ports. The pump casing shall be drilled and tapped for gauge ports at both the suction and discharge flanges and for drain port at the bottom of the casing. Optional bronze wear ring can be fitted to the casing. The pump shall be capable of being serviced without disturbing system piping.

The impeller shall be bronze and hydraulically balanced by either back vanes or balancing holes. The impeller shall be dynamically balanced to ANSI Grade G6.3 and shall be fitted to the shaft with a key.

The pump cover shall be machined to provide a balance chamber from the close tolerance between the back impeller hub and the cover. The cover shall be fitted with a bronze throttle bushing as standard. The cover shall be designed to provide maximum flexibility of mechanical shaft seals and flush glands.

The pump seal shall be EPT Ceramic rated to 250 degrees F.\*\*. Optional seat materials and elastomers are available. The pump shall have a factory installed vent/flush line to insure removal of trapped air and mechanical seal cooling. The vent/flush line shall run from the seal chamber to the pump discharge. Extended seal life can be accomplished with an optional filter or sediment separator, which can be incorporated in the vent/flush line.

The pump shall be coupled to a NEMA rated motor designed for continuous operation and readily removable for servicing. The pump shaft shall be of stainless steel and incorporate a suitable internal or external seal. The pump and motor shaft must be connected with circular keys capable of transmitting axial loads to the motor bearings. The motor shall be connected to the pump shaft through a high tensile aluminum split style coupling.

\*\* For operating temperatures above 250 degrees F., a cooled flush is required and is recommended for temperatures above 225 degrees F. for optimum seal life. On closed systems, insert a small heat exchanger in the flush line to cool the seal flushing fluid.



## KS Vertical Split Coupled In-Line Pump Materials of Construction

Description	Bronze Fitted		All Iron	
	Standard*	Optional	Standard	Optional
Casing	Cast Iron ASTM A48 CLASS 30		Cast Iron ASTM A48 CLASS 30A	
Impeller	Bronze ASTM B584-836 Silicon Bronze ASTM B584-875		Cast Iron ASTM A48 CLASS 30A	
Wear Ring	None	Bronze ASTM B584-932 SAE660	None	N/A
Shaft	Stainless Steel AISI 416 ASTM A582		Stainless Steel AISI 416 ASTM A582	
Mechanical Seal: Stationary Seat	Aluminum Alloy 6061-T6 Inside Seal: Ceramic EPT	Inside Seal: Ni-Resist or Tungsten Carbide	Aluminum Alloy 6061-T6 Inside Seal: Ceramic EPT	Inside Seal: Ni-Resist or Tungsten Carbide
Rotating Face	Carbon		Carbon	
Elastomer	Ethylene Propylene	Viton	Ethylene Propylene	Viton
Spring	Stainless Steel		Stainless Steel	
Seal Flush Line	Copper	Stainless Steel	Stainless Steel	

\* Standard Pump Construction

## KS Series Performance Field 1160 RPM

Curves also available on TacoNet.

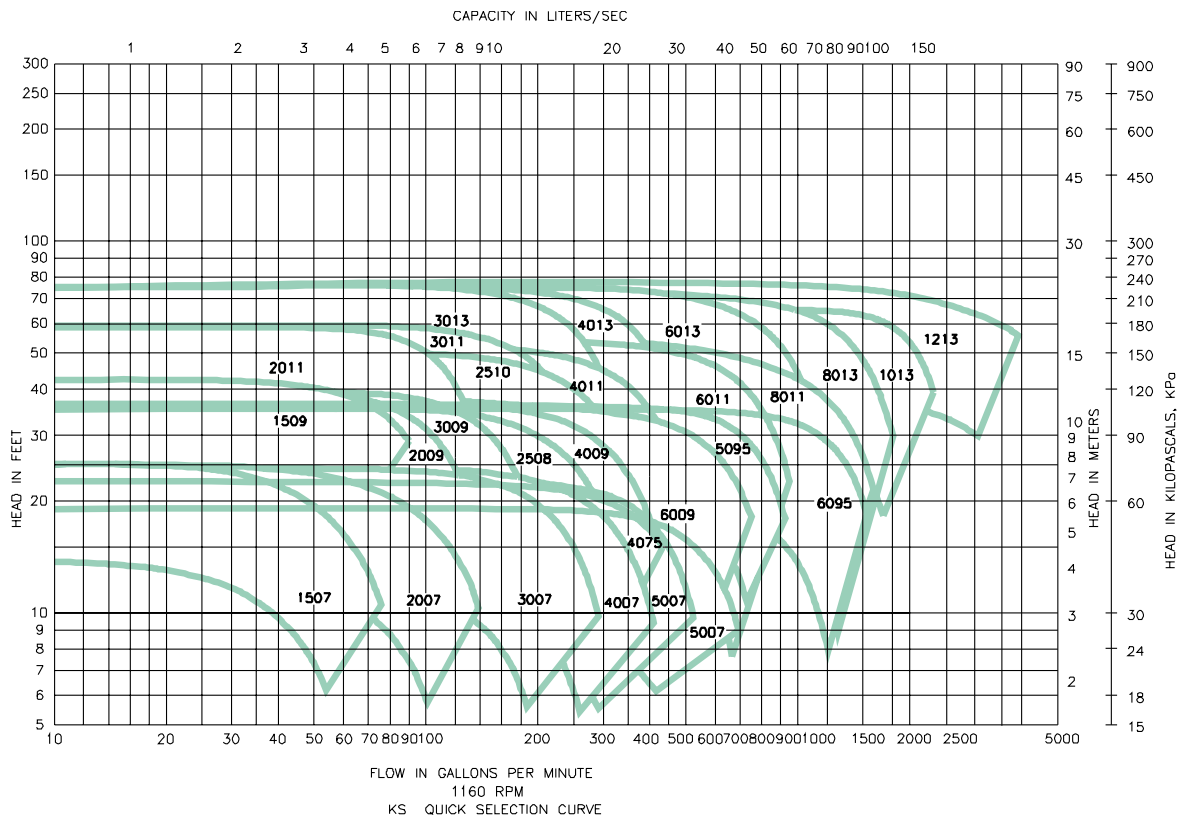

# Commercial Hydronic Application Information

## KS Series Performance Field 1760 RPM

Curves also available on TacoNet.

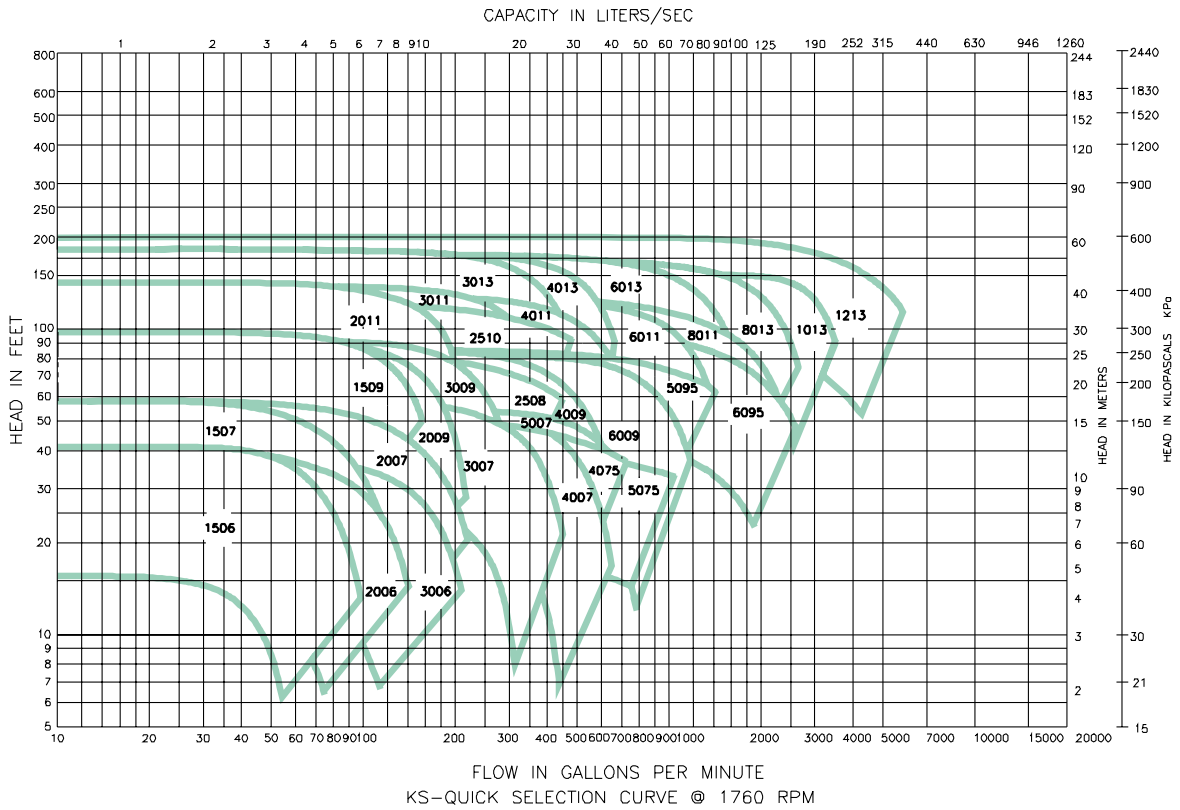

## KS Series Performance Field 3500 RPM

Curves also available on TacoNet.

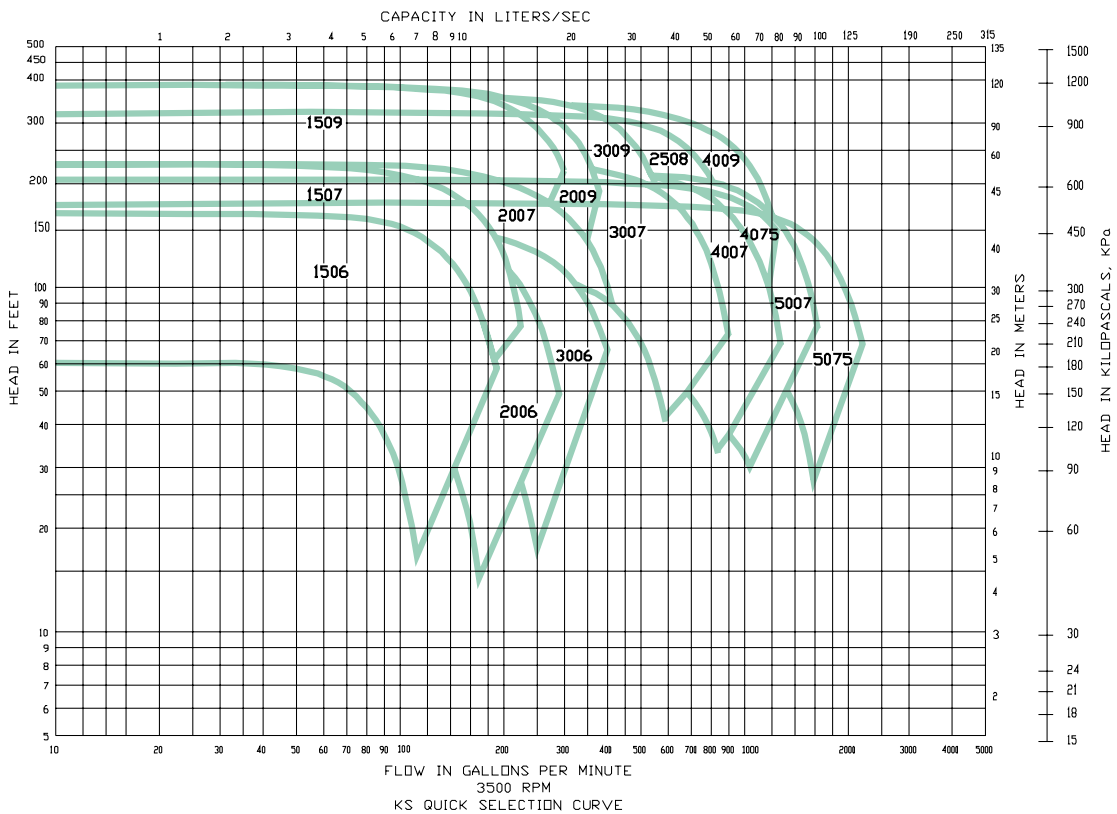

## KS Vertical Inline Pump Dimensions

MODEL NO. "KS"	PRESSURE CLASS-125#		PRESSURE CLASS-250#		C	D	F	G	E MAX.	J DIA
	A	B	A	B						
1 1/2X1 1/2X6 (KS1506)	7.50(191MM)	7.50(191MM)	7.75(197MM)	7.75(197MM)	4.49(114MM)	15.08(383MM)	4.13(105MM)	4.63(118MM)	13.05(331MM)	7.05(179MM)
									14.05(357MM)	
									15.64(397MM)	8.49(216MM)
									16.68(424MM)	
2X2X6 (KS2006)	7.50(191MM)	8.00(203MM)	7.75(197MM)	8.25(210MM)	3.91(99MM)	14.54(369MM)	4.41(112MM)	5.14(131MM)	13.05(331MM)	7.05(179MM)
									14.05(357MM)	
									15.64(397MM)	8.49(216MM)
									16.68(424MM)	
									19.13(486MM)	10.18(259MM)
3X3X6 (KS3006)	8.50(216MM)	10.00(254MM)	8.87(225MM)	10.37(263MM)	4.97(126MM)	15.56(395MM)	4.67(119MM)	5.56(141MM)	13.05(331MM)	7.05(179MM)
									14.05(357MM)	
									15.64(397MM)	8.49(216MM)
									16.68(424MM)	
									19.13(486MM)	10.18(259MM)
20.63(524MM)										
1 1/2X1 1/2X7 (KS1507)	8.00(203MM)	8.00(203MM)	8.31(211MM)	8.31(211MM)	4.13(105MM)	14.85(377MM)	4.88(124MM)	5.16(131MM)	13.05(331MM)	7.05(179MM)
									14.05(357MM)	
									15.64(397MM)	8.49(216MM)
									16.68(424MM)	
									19.13(486MM)	10.18(259MM)
20.63(524MM)										
2X2X7 (KS2007)	8.50(216MM)	8.50(216MM)	8.76(223MM)	8.76(223MM)	3.94(100MM)	14.70(373MM)	4.88(124MM)	5.45(138MM)	13.05(331MM)	7.05(179MM)
									14.05(357MM)	
									15.64(397MM)	8.49(216MM)
									16.68(424MM)	
									19.13(486MM)	10.18(259MM)
									20.63(524MM)	
24.36(619MM)	12.88(327MM)									
26.11(663MM)										
3X3X7 (KS3007)	10.00(254MM)	10.00(254MM)	10.37(263MM)	10.37(263MM)	6.30(160MM)	16.96(431MM)	5.29(134MM)	6.31(160MM)	13.05(331MM)	7.05(179MM)
									14.05(357MM)	
									15.64(397MM)	8.49(216MM)
									16.68(424MM)	
									19.13(486MM)	10.18(259MM)
									20.63(524MM)	
24.36(619MM)	12.88(327MM)									
26.11(663MM)										
4X4X7 (KS4075)	11.81(300MM)	10.81(274MM)	12.12(307MM)	11.12(282MM)	6.94(176MM)	18.40(467MM)	5.61(142MM)	6.99(177MM)	14.05(357MM)	7.05(179MM)
									15.64(397MM)	
									16.68(424MM)	8.49(216MM)
									19.13(486MM)	
									27.94(710MM)	14.63(372MM)
									29.14(740MM)	
31.07(789MM)	16.50(419MM)									
32.57(827MM)										
4X4X7 (KS4007)	11.00(279MM)	11.00(279MM)	11.32(288MM)	11.32(288MM)	6.59(167MM)	17.64(448MM)	5.64(143MM)	6.80(173MM)	13.05(331MM)	7.05(179MM)
									14.05(357MM)	
									15.64(397MM)	8.49(216MM)
									16.68(424MM)	
									19.13(486MM)	10.18(259MM)
									24.36(619MM)	
									26.11(663MM)	12.88(327MM)
									27.94(710MM)	
29.14(740MM)	14.63(372MM)									
31.07(789MM)		16.50(419MM)								

## KS Vertical Inline Pump Dimensions, continued

MODEL NO. "KS"	PRESSURE CLASS-125#		PRESSURE CLASS-250#		C	D	F	G	E MAX	J DIA
	A	B	A	B						
5X5X7 (KS5007)	13.00(330MM)	11.00(279MM)	13.44(341MM)	11.44(291MM)	6.63(168MM)	18.02(458MM)	6.42(163MM)	7.91(201MM)	14.05(357MM)	7.05(179MM)
									15.64(397MM)	8.49(216MM)
									16.68(424MM)	10.18(259MM)
									19.13(486MM)	12.88(327MM)
									20.63(524MM)	14.63(372MM)
									24.36(619MM)	16.50(419MM)
									26.11(663MM)	18.25(464MM)
									27.94(710MM)	19.99(509MM)
									29.14(740MM)	21.73(554MM)
5X5X7 (KS5075)	14.00(355MM)	11.00(279MM)	14.44(366MM)	11.44(291MM)	8.07(205MM)	19.65(499MM)	6.31(160MM)	8.10(205MM)	14.05(357MM)	7.05(179MM)
									15.64(397MM)	8.49(216MM)
									16.68(424MM)	10.18(259MM)
									19.13(486MM)	12.88(327MM)
									20.63(524MM)	14.63(372MM)
									24.36(619MM)	16.50(419MM)
									26.11(663MM)	18.25(464MM)
									27.94(710MM)	19.99(509MM)
									29.14(740MM)	21.73(554MM)
2 1/2X 2 1/2X8 (KS 2508)	9.56(242MM)	9.00(228MM)	9.88(250MM)	9.31(236MM)	5.88(149MM)	16.70(424MM)	6.10(155MM)	6.99(177MM)	14.05(357MM)	7.05(179MM)
									15.64(397MM)	8.49(216MM)
									16.68(424MM)	10.18(259MM)
									19.13(486MM)	12.88(327MM)
									20.63(524MM)	14.63(372MM)
									24.36(619MM)	16.50(419MM)
									26.11(663MM)	18.25(464MM)
									27.94(710MM)	19.99(509MM)
									29.14(740MM)	21.73(554MM)
1 1/2X1 1/2X9 (KS1509)	8.00(203MM)	8.00(203MM)	8.31(211MM)	8.31(211MM)	4.36(111MM)	15.05(382mm)	5.72(145MM)	6.22(158MM)	13.05(331MM)	7.05(179MM)
									14.05(357MM)	8.49(216MM)
									15.64(397MM)	10.18(259MM)
									16.68(424MM)	12.88(327MM)
									19.13(486MM)	14.63(372MM)
									20.63(524MM)	16.50(419MM)
									24.36(619MM)	18.25(464MM)
									26.11(663MM)	19.99(509MM)
									27.94(710MM)	21.73(554MM)
2X2X9 (KS2009)	9.00(229MM)	10.00(254MM)	9.25(235MM)	10.25(260MM)	3.94(100MM)	14.72(374MM)	5.72(145MM)	6.22(158MM)	13.05(331MM)	7.05(179MM)
									14.05(357MM)	8.49(216MM)
									15.64(397MM)	10.18(259MM)
									16.68(424MM)	12.88(327MM)
									19.13(486MM)	14.63(372MM)
									20.63(524MM)	16.50(419MM)
									24.36(619MM)	18.25(464MM)
									26.11(663MM)	19.99(509MM)
									27.94(710MM)	21.73(554MM)
3X3X9 (KS3009)	10.00(254MM)	11.00(279MM)	10.37(263MM)	11.37(289MM)	5.19(132MM)	15.90(404MM)	5.94(151MM)	6.53(166MM)	13.05(331MM)	7.05(179MM)
									14.05(357MM)	8.49(216MM)
									15.64(397MM)	10.18(259MM)
									16.68(424MM)	12.88(327MM)
									19.13(486MM)	14.63(372MM)
									20.63(524MM)	16.50(419MM)
									24.36(619MM)	18.25(464MM)
									26.11(663MM)	19.99(509MM)
									27.94(710MM)	21.73(554MM)

## KS Vertical Inline Pump Dimensions, continued

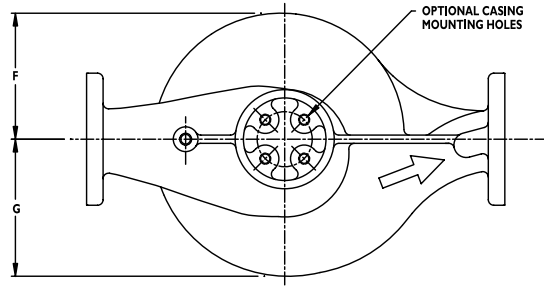
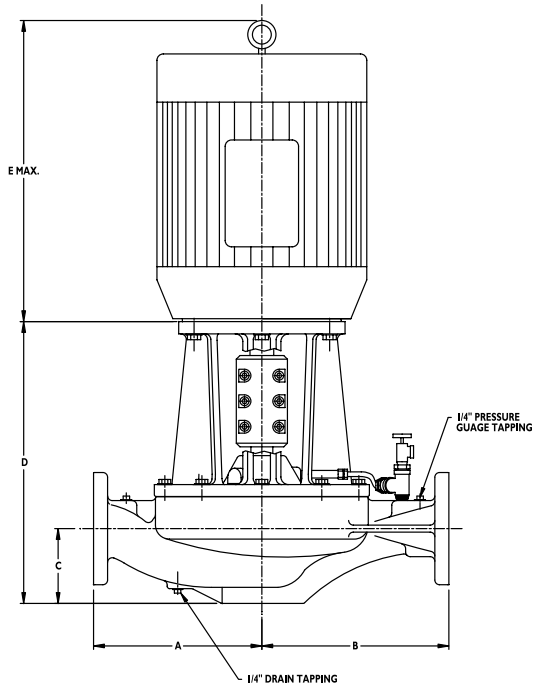

MODEL NO. "KS"	PRESSURE CLASS-125#		PRESSURE CLASS-250#		C	D	F	G	E MAX.	J DIA
	A	B	A	B						
4X4X9 (KS4009)	11.00(279MM)	13.00(330MM)	11.32(288MM)	13.32(338MM)	6.19(157MM)	17.01(432MM)	6.28(160MM)	7.25(184MM)	14.05(357MM)	7.05(179MM)
						15.64(397MM)			8.49(216MM)	
						16.68(424MM)			10.18(259MM)	
						19.13(486MM)			12.88(327MM)	
						20.63(524MM)			14.63(372MM)	
						24.36(619MM)			16.50(419MM)	
						27.94(710MM)				
29.14(740MM)										
5X5X9 (KS5095)	14.00(355MM)	11.00(279MM)	14.44(366MM)	11.44(290MM)	7.34(186MM)	18.68(474MM)	7.37(187MM)	9.08(230MM)	19.13(486MM)	10.18(259MM)
						21.45(544MM)			12.88(327MM)	
						24.36(619MM)			14.63(372MM)	
						26.11(663MM)				
						27.94(710MM)				
6X6X9 (KS6095)	16.00(406MM)	14.00(355MM)	16.44(417MM)	14.44(366MM)	9.24(234)	21.21(538MM)	8.32(211MM)	10.54(267MM)	20.63(524MM)	10.18(259MM)
						23.98(609MM)			12.88(327MM)	
						25.73(653MM)			14.63(372MM)	
									16.50(419MM)	
6X6X9 (KS6009)	13.50(343MM)	15.50(394MM)	13.82(351MM)	15.82(402MM)	6.60(168MM)	17.87(454MM)	7.62(194MM)	9.31(236MM)	16.68(424MM)	8.49(216MM)
						20.64(524MM)			10.18(259MM)	
									12.88(327MM)	
									14.63(372MM)	
2 1/2 X 2 1/2 X 10 (KS2510)	11.25(285MM)	9.75(247MM)	11.56(293MM)	10.06(255MM)	6.79(172MM)	17.73(450MM)	7.06(179MM)	7.71(195MM)	16.68(424MM)	8.49(216MM)
						20.55(522MM)			10.18(259MM)	
									12.88(327MM)	

**HYDRONIC COMPONENTS & SYSTEMS**

**Do it once.  
Do it right.**  **Taco**<sup>®</sup>

Taco Inc., 1160 Cranston Street, Cranston, RI 02920 / (401) 942-8000 / Fax (401) 942-2360  
Taco (Canada) Ltd., 6180 Ordan Drive, Mississauga, Ontario L5T 2B3 / (905) 564-9422 / Fax (905) 564-9436  
[www.taco-hvac.com](http://www.taco-hvac.com)